

GRUNDFOS PRODUCT GUIDE

SP

Submersible pumps, motors, and accessories
60 Hz

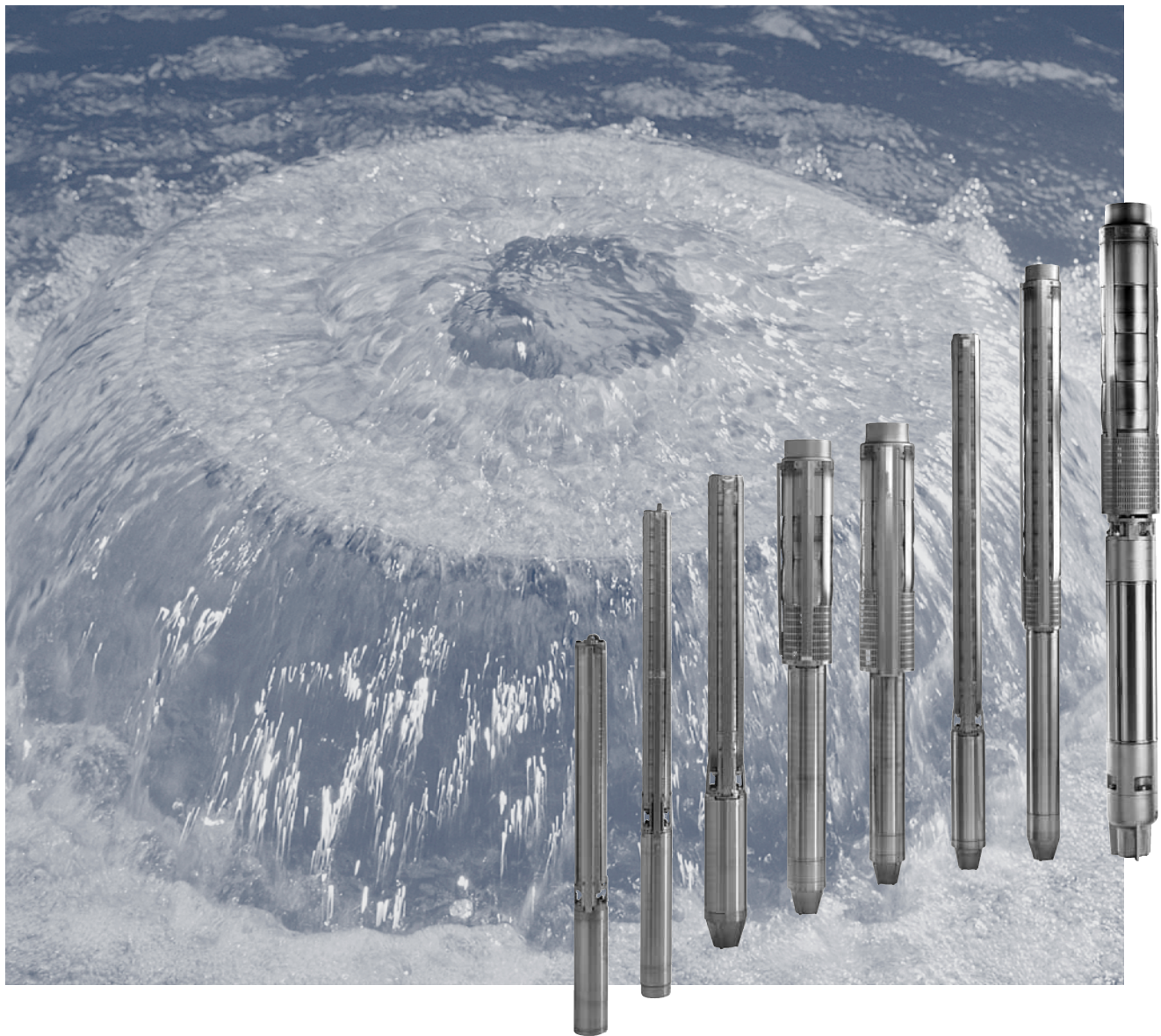

1. Product introduction	3
Introduction	3
Applications	3
Features and benefits	3
Identification	8
2. Product overview	9
Performance range 60 Hz	9
Pump range	10
Motor range	10
Motor protection and controllers	10
3. Construction	11
4. Operating conditions	18
Operating conditions	18
Curve conditions	18
5. How to read the curve charts	19
6. Curve charts and technical data	20
5S (5 gpm)	20
7S (7 gpm)	22
10S (10 gpm)	24
16S (16 gpm)	26
25S (25 gpm)	28
40S (40 gpm)	30
60S (60 gpm)	32
75S (75 gpm)	34
85S (85 gpm)	36
150S (150 gpm)	42
230S (230 gpm)	48
300S (300 gpm)	54
385S (385 gpm)	60
625S (625 gpm)	70
800S (800 gpm)	75
1100S (1100 gpm)	80
Electrical data	85
7. Accessories	86
MP 204	86
Control functions	89
G100 gateway for communication with Grundfos products	92
Connecting pieces	94
Zinc anodes	95
SA-SPM 5 control boxes	96
Pt100	97
8. Energy consumption	98
Energy consumption of submersible pumps	98
9. Cables	99
Cable sizing chart	100
10. Friction loss tables	102
11. Further product documentation	104
WebCAPS	104
WinCAPS	105

1. Product introduction

Introduction

The Grundfos SP range of submersible pumps is renowned for high efficiency and reliability. Made entirely of corrosion resistant stainless steel, SP pumps are ideal for a wide variety of applications.

Grundfos SP pumps represent state-of-the-art hydraulic design. Built to deliver optimum efficiency during periods of high demand, SP pumps provide low long-term costs and high operating reliability regardless of the application.

The SP range offers high efficiency, high resistance to sand and other abrasives, motor burnout protection, and easy maintenance. A complete monitoring and control system is available for constant optimization of the pumping system.



Fig. 1 Grundfos SP pumps

TM05 0051 0611

Applications

Grundfos Large SP submersible pumps are suitable for:

- Groundwater supply to waterworks
- Irrigation in horticulture and agriculture
- Groundwater lowering (dewatering)
- Pressure boosting
- Industrial applications
- Domestic water supply.

Pumped liquids

Grundfos SP pumps are suitable for pumping clean, thin, non-aggressive liquids without solid particles or fibers.

SP offers stainless steel construction which ensures good wear resistance and a reduced risk of corrosion where the water has minor chloride content.

Optional, upgraded stainless steel construction is available for pumping more aggressive liquids:

A complete range of zinc anodes for cathodic protection is available; see p. 97 for applications (for example, sea water applications).

For slightly polluted liquids (for example, containing oil), Grundfos offers a complete range of stainless steel SP NE pumps with all rubber parts made of FKM.

Features and benefits

Grundfos SP submersible pumps offer these features and benefits:

- State-of-the-art hydraulics provide high efficiency and low operating costs
- 100 % stainless steel components inside and outside for long service life
- Sand resistant
- Resistant to aggressive water
- Motor burnout protection via CU 301
- Dry-running protection
- Monitoring, protection and communication via protection unit MP204, and remote control, R100.

A wide pump range

Grundfos offers energy-efficient SP submersible pumps with a performance range of up to 1,400 gpm and 2,100 ft of head.

The pump range consists of many pump sizes, and each pump size is available with an optional number of stages to match any duty point.

High pump efficiency

Often pump efficiency is given less consideration than the price of a pump; however, owners who choose efficiency will find substantial savings in energy costs over time. See fig. 2 for an illustration of SP efficiencies in relation to flow.

Example

For example, a pump and motor with a 10 % higher efficiency than a cheaper, less efficient pump, can save its owner more than \$80,000.00 over 10 years*.

* If producing 880 gpm at 325 ft of head for 10 years @ 13.8 cents per kWh. U.S. kWh costs range from 6 cents to more than 20 cents, depending on region.

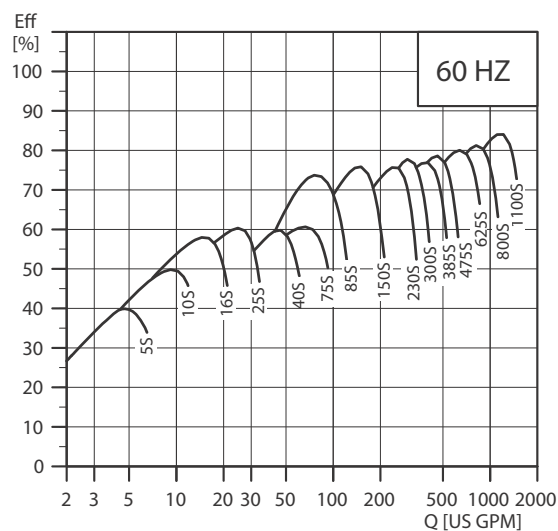

Fig. 2 SP pump/motor efficiencies in relation to flow

TM05 0057 0711

Pump design

Grundfos SP submersible pumps feature components that contribute to the superior performance and durability of the range.

Lower installation costs

Stainless steel means low weight for ease in the handling of pumps, resulting in lower equipment costs and reduced installation and service time.

Bearings with sand channels

All bearings are water-lubricated and have a squared shape enabling sand particles, if any, to leave the pump together with the pumped liquid.

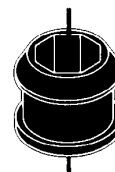

Fig. 3 Bearing

TM00 7301 1096

Inlet strainer

The inlet strainer prevents particles over a certain size from entering the pump.



Fig. 4 Fig. Inlet strainer

TM00 7302 1096

Non-return valve

All pumps are equipped with a reliable check valve in the valve casing preventing back flow in connection with pump stoppage.

Furthermore, the short closing time of the check valve means that the risk of destructive water hammer is reduced to a minimum.

The valve casing is designed for optimum hydraulic properties to minimize the pressure loss across the valve and thus to contribute to the high efficiency of the pump.

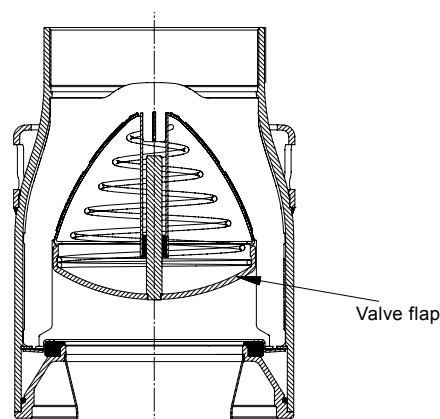

Fig. 5 Check valve

TM01 2493 1798

Priming screw

All Grundfos 4" pumps are fitted with a priming screw. Consequently, dry running is prevented, because the priming screw will make sure that pump bearings are always lubricated.

Due to the semi-axial impellers of large SP pumps this priming is provided automatically.

However, it applies to all pump types that if the water table is lowered to a level below the pump inlet neither pump nor motor will be protected against dry running.

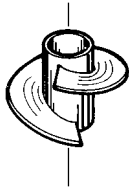

Fig. 6 Priming screw

TM00 7304 1096

Stop ring

The stop ring prevents damage to the pump during transport and in case of up-thrust in connection with start-up.

The stop ring, which is designed as a thrust bearing, limits axial movements of the pump shaft.

Example: SP 385S

The stationary part of the stop ring (A) is secured in the upper intermediate chamber.

The rotating part (B) is fitted above the split cone (C).

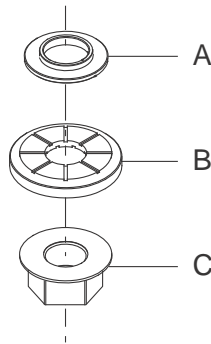

Fig. 7 Stop ring (rotating and stationary part) and the split cone

TM01 3327 0412

Grundfos submersible motors

A complete motor range

Grundfos offers a complete submersible motor range in different voltages. For an overview of motor types, sizes and voltages, see page 85.

MS 402 is designed for the domestic ground water market and covers outputs. The MS 4000 and MS6 series are designed for use in a variety of applications in water supply. When equipped with features like oversized motor, temperature measurement, cooling jacket, and SiC/SiC mechanical shaft seals, these motors are suitable for heavy-duty industrial applications such as dewatering operations.

As a standard, all external surfaces of the Grundfos MS motors in contact with water are made of AISI 304 stainless steel. For aggressive water, such as seawater or brackish water, R-versions made of AISI 904 are available.

Grundfos rewindable MMS motor range

Grundfos MMS motors are suitable for any submersible installation, including heavy-duty industrial applications and dewatering operations (when equipped with temperature control, oversized motor, cooling jacket, and SiC/ SiC mechanical shaft seals).

As a standard the MMS motors are supplied with black cast-iron end-bells. Optionally, the range is available in all-stainless steel AISI 316 or AISI 904 versions.

The 2-pole Grundfos MMS submersible motors are all easy to rewind. The windings of the stator are made of a special water-proof wire of pure electrolytic copper sheathed with special non-hydroscopic thermoplastic material. The fine dielectric properties of this material allow direct contact between the windings and the liquid for efficient cooling of the windings.



Fig. 8 Grundfos MS motors

TM00 7305 1096 - GRA4011 - GRA4013



Fig. 9 Grundfos MMS motors

TM01 7873 4799

Industrial submersible motors and MS6 T60-versions

For heavy-duty applications Grundfos offers a complete motor range of industrial motors with up to 5 % higher efficiency than that of Grundfos' standard motors. The industrial motors are available in sizes as from 3 Hp up to 30 Hp.

The cooling of the motor is very efficient due to the large motor surface. The efficient cooling makes it possible to increase the liquid temperature to 140 °F (60 °C) at a minimum flow of 0.49 ft/s (0.15 m/s) past the motor.

The industrial motors are for customers who value low operating costs and long life higher than price.

Grundfos industrial motors are developed for difficult operating conditions. These motors will stand a higher thermal load than standard motors and thus have a longer life when subjected to high load. This applies whether the high load is caused by bad power supply, hot water, bad cooling conditions, high pump load etc.

Please note that heavy duty motors are longer than motors for standard conditions.

Overtemperature protection

Accessories for protection against overtemperature are available for both Grundfos MS and MMS submersible motors. When the temperature becomes too high, the protection device will cut out and damage to the pump and motor be avoided.

Restart of the motor after cut-out can be achieved in two ways:

- manual restart
- automatic restart.

Automatic restart means that the MP 204 attempts to restart the motor after 15 minutes. If the first attempt is not successful, restarting will be reattempted at 30-minute intervals.

MS

The Grundfos MS submersible motors (with the exception of MS 402) are available with a built-in Tempcon temperature transmitter for protection against overtemperature. By means of the transmitter, it is possible to read out and/or monitor the motor temperature via an MP 204 or a PR 5714 relay.

The Grundfos MS6 submersible motors can be fitted with a Pt100. The Pt100 is fitted in the motor and connected directly to the MP 204 or monitored by the PR 5714 relay.

MMS

For the protection of the Grundfos MMS submersible motors against overtemperature Grundfos offers the Pt100 temperature sensor as an optional extra.

The Pt100 is fitted in the motor and connected directly to the MP 204 or monitored by the PR 5714 relay.

Protection against upthrust

In case of a very low counter pressure in connection with start-up there is a risk that the entire chamber stack may rise. This is called upthrust. Upthrust may damage both pump and motor. Both Grundfos pumps and motors are protected against upthrust as standard, preventing upthrust from occurring during the critical start-up phase. The protection consists of either a built-in stop ring or hydraulic balancing.

Built-in cooling chambers

In all Grundfos MS submersible motors, efficient cooling is ensured by cooling chambers at the top and at the bottom of the motor, and by an internal circulation of motor liquid.

See fig. 10. As long as the required flow velocity past the motor is maintained, cooling of the motor will be efficient.

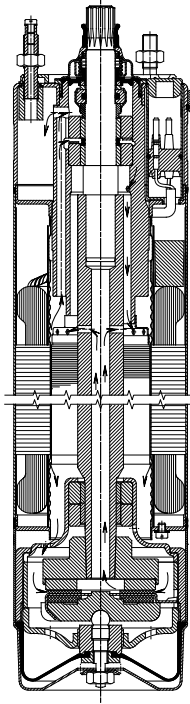

Fig. 10 MS 4000

TM00 5698 0996

Lightning protection

The smallest Grundfos submersible motors, such as the MS 402, are all insulated in order to minimize the risk of motor burnout caused by lightning strike.

Reduced risk of short-circuit

The embedded stator winding in the Grundfos MS submersible motor is hermetically enclosed in stainless steel. The result is high mechanical stability and optimum cooling. Also, this eliminates the risk of short-circuit of the windings caused by water condensation.

Shaft seal

MS 402

The shaft seal is of the lip seal type characterized by low friction against the rotor shaft.

The rubber material offers good wear resistance, good elasticity and resistance to particles, and it is approved for use in drinking water.

MS 4000, MS6

The material is ceramic/tungsten carbide providing optimum sealing, optimum wear resistance and long life.

The spring loaded shaft seal is designed with a large surface and a sand shield. The result is a minimum exchange of pumped and motor liquids and no penetration of particles.

Motors, version R, are supplied with a SiC/SiC shaft seal. Other combinations are available request. See fig. 11 and fig. 12 for an illustration of shaft seal components and configuration.

MMS rewindable motors

The standard shaft seal is a ceramic/carbon mechanical shaft seal. The shaft seal is replaceable. The material features good wear resistance and resistance to particles.

Together with the shaft seal housing, the sand shield forms a labyrinth seal, which during normal operating conditions prevents penetration of sand particles into the shaft seal.

On request, motors can be supplied with a SiC/SiC seal.

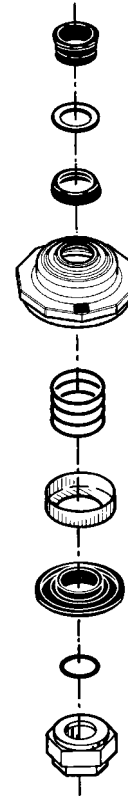

Fig. 11 Shaft seal, MS 4000

TM00 7306 0412

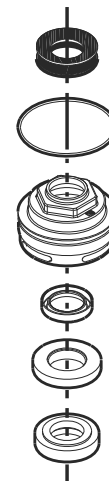

Fig. 12 Shaft seal, MS6

TM03 9225 3607

Identification

Type key, SP pumps

Example	475	S	500	-	5	-	A	B
Rated flow rate in gpm								
Type range								
Stainless steel parts of material								
S= AISI 304								
N= AISI 316								
R= AISI 904L								
Hp of motor								
Number of impellers								
First reduced-diameter impeller (A, B or C)								
Second reduced-diameter impeller (A, B or C)								

Type key, MS 4000 motors

Example	MS	4	000	R
Motor submersible				
Min. borehole diameter in inches				
Generation				
- = Stainless steel AISI 304				
R = Stainless steel AISI 904L				
I = Stainless steel AISI 304 + De-rated				
RE = Stainless steel AISI 904 L + FKM				
EI = Stainless steel AISI 304 + De-rated + FKM				

Type key, MS 402 motors

Example	MS	4	02
Motor submersible			
Min. borehole diameter in inches			
Generation			
- = Stainless steel AISI 304			

Type key, MMS motors

Example	MMS	6	000	N
Type range				
Min. borehole diameter in inches				
Generation				
Material:				
= Cast iron EN-JL1040				
N = DIN/EN 1.4401 (AISI 316)				

Type key, MS6 motors

Example	MS	6	R	E	S	W	D	T60
Type range (Motor Submersible)								
Motor diameter in inches								
Material								
• Blank = stainless steel EN 1.4301 (AISI 304)								
• R = stainless steel EN 1.4539 (AISI 904L)								
Rubber parts								
• Blank = NBR								
• E = FKM								
Shaft seal								
• Blank = ceramics/carbon								
• S = SiC/SiC								
Radial bearings								
• Blank = carbon/stainless steel								
• W = SiC/tungsten carbide								
Motor liquid								
• Blank = SML-3								
• D = demineralized water								
Maximum liquid temperature								
• T30 = 86 °F (30 °C)								
• T60 = 140 °F (60 °C)								

2. Product overview

Performance range 60 Hz

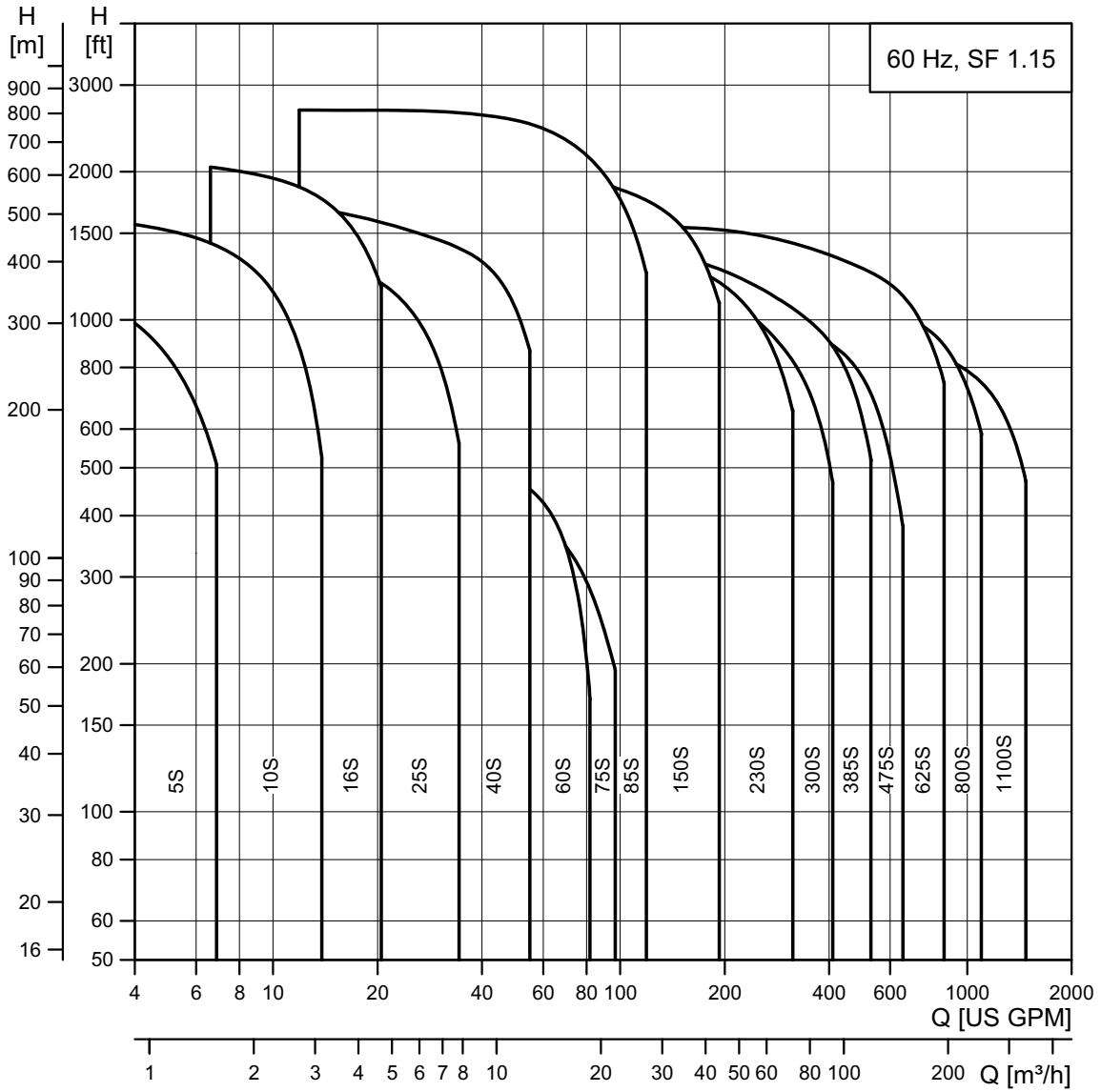

TM05 0056 0112

Pump range

Type	5S	10S	16S	25S	40S	60S	75S	85S	150S	230S	300S	385S	475S	625S	800S	1100S	
AISI 304 stainless steel	●	●	●	●	●	●	●	●	●	●	●	●	●	●	●	●	
AISI 316 stainless steel			●	●	●		●	●	●	●	●	●	●	●	●	●	
AISI 904L stainless steel				●	●			●	●	●	●	●	●	●	●	●	
Connection ★	NPT	1"	1.25"	1.25"	1.5"	2"	2"	2"	(3")	(3")	3" (4")	3" (4")	5"	5"	6"	6"	6"
Flange connection: Grundfos flange													5"	5"	6"	6"	6"

★ Figures in brackets () indicate connection for pumps with sleeve.

Motor range

Motor output [hp]	0.5	0.75	1.0	1.5	1.5	3.0	5.0	7.5	10.0	15	20	25	30	40	50	60	75	100	125	150	175	200	250	
Single-phase	●	●	●	●	●	●																		
Three-phase	●	●	●	●	●	●	●	●	●	●	●	●	●	●	●	●	●	●	●	●	●	●	●	●
Industrial motor and MS6 T60-versions						●	●	●	●	●	●	●	●											
Rewindable motor						●	●	●	●	●	●	●	●	●	●	●	●	●	●	●	●	●	●	●
Steel: AISI 304	●	●	●	●	●	●	●	●	●	●	●	●	●	●										
Steel: AISI 304 and cast iron						●	●	●	●	●	●	●	●	●	●	●	●	●	●	●	●	●	●	●
Steel: AISI 316						●	●	●	●	●	●	●	●	●	●	●	●	●	●	●	●	●	●	●
Steel: AISI 904L			●	●	●	●	●	●	●	●	●	●	●	●	●	●	●	●	●	●	●			
Built-in temperature transmitter in motor		●	●	●	●	●	●	●	●	●	●	●	●											

Direct-on-line starting is recommended up to 100 hp.

Soft starter or autotransformer is recommended above 100 hp.

Motors with star/delta are available from 7.5 hp.

Motor protection and controllers

Motor output [hp]	0.5	0.75	1.0	1.5	1.5	3.0	5.0	7.5	10.0	15	20	25	30	40	50	60	75	100	125	150	175	200	250	
MP 204	●	●	●	●	●	●	●	●	●	●	●	●	●	●	●	●	●	●	●	●	●	●	●	●
Pt100						●	●	●	●	●	●	●	●	●	●	●	●	●	●	●	●	●	●	●
Zinc anode				●	●	●	●	●	●	●	●	●	●	●	●	●	●	●	●	●	●	●	●	●
Vertical flow sleeve	●	●	●	●	●	●	●	●	●	●	●	●	●	●	●	●	●	●	●	●	●	●	●	●
Horizontal flow sleeve	●	●	●	●	●			●	●	●	●	●	●	●										
SA-SPM	●	●	●	●	●	●																		
R100	●	●	●	●	●	●	●	●	●	●	●	●	●	●	●	●	●	●	●	●	●	●	●	●
RS-485 communication module	●	●	●	●	●	●	●	●	●	●	●	●	●	●	●	●	●	●	●	●	●	●	●	●
G100	●	●	●	●	●	●	●	●	●	●	●	●	●	●	●	●	●	●	●	●	●	●	●	●

Motor protection of single-phase motors, see page 85.

3. Construction

Sectional drawing, SP pump, 4"

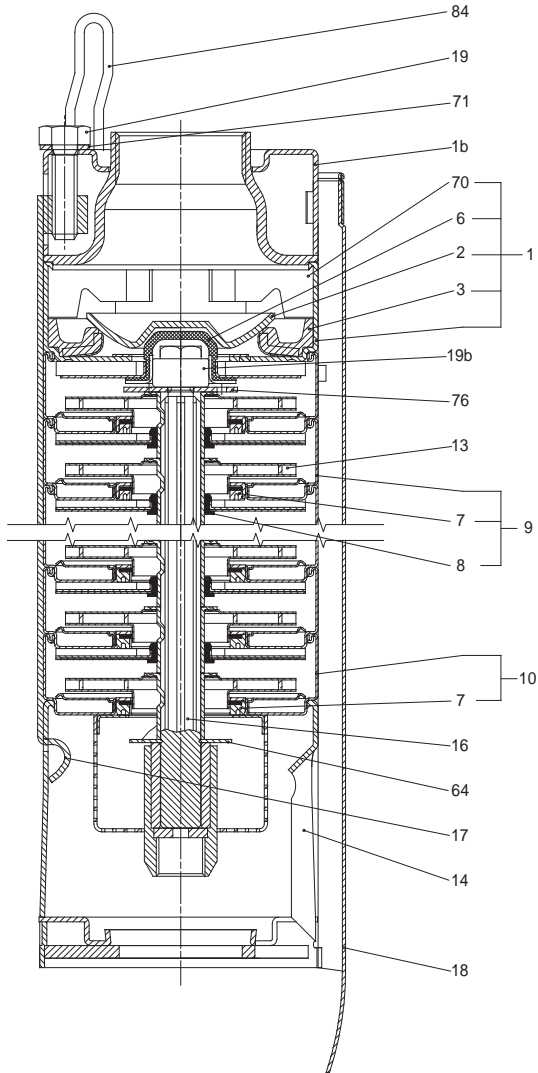

TM00 5606 1907

Fig. 13 SP pump, 4"

Material specification, SP pump, 4"

Pos.	Component	Materials	Standard
			AISI
1	Valve casing	Stainless steel	304
1b	Discharge piece	Stainless steel	304
2	Valve cup	Stainless steel	304
3	Valve seat	Stainless steel/NBR	304
6	Top bearing	NBR	
7	Neck ring	NBR/PBT	
8	Intermediate ring	NBR	
9	Intermediate chamber	Stainless steel	304
10	Bottom intermediate chamber	Stainless steel	304
13	Impeller	Stainless steel	304
14	Suction interconnector	Stainless steel	304
16	Shaft	Stainless steel	304
17	Strap	Stainless steel	304
18	Cable guard	Stainless steel	304
19	Hexagon screw	Stainless steel	304
19a	Nut	Stainless steel	316
19b	Nut	Stainless steel	304
20	Motor cable		
64	Priming disc	Stainless steel	304
70	Valve guide	Stainless steel	304
71	Washer for pos. 19	Stainless steel	316
76	Washer	Stainless steel	304
78	Nameplate	Stainless steel	316
84	Hook	Stainless steel	304

Sectional drawing, SP pump, 6"

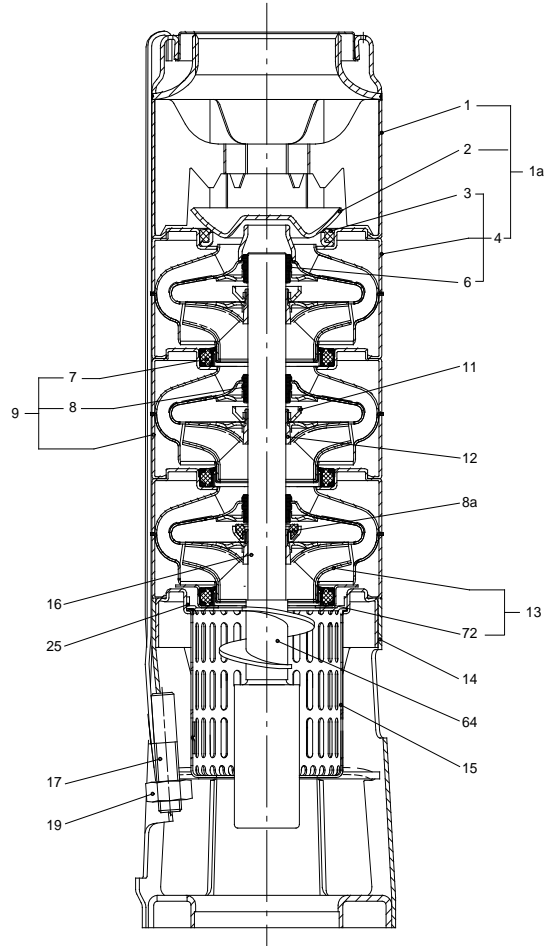

Fig. 14 SP pump, 6"

TM01 2258 2602

Material specification, SP pump, 6"

Pos.	Component	Materials	Standard	N-version	R-version
			AISI		
Valve casing					
1	Valve casing	Stainless steel	304	316	904 L
2	Valve cup	Stainless steel	304	316	904 L
3	Valve seat	Stainless steel	304	316	904 L
4	Top chamber	Stainless steel	304	316	904 L
Chamber stack					
7	Neck ring	NBR/PPS			
8	Bearing	NBR			
8a	Spacing washer	Carbon/ graphite HY22 in PTFE mass			
9	Chamber	Stainless steel	304	316	904 L
11	Nut for split cone	Stainless steel	304	316	904 L
12	Split cone	Stainless steel	304	316	904 L
13	Impeller	Stainless steel	304	316	904 L
16	Shaft with coupling	Stainless steel	431	329	Si 31 803
18	Cable guard	Stainless steel	304	316	904 L
23	Rubber guard	NBR			
25	Neck ring retainer	Stainless steel	304	316	904 L
64	Priming screw	Stainless steel	304	316	904 L
72	Wear ring	Stainless steel	304	316	904 L
Suction interconnector					
14	Suction interconnector	Stainless steel	304	316	904 L
	Intermediate piece for 6" motor over 40 Hp	Stainless steel	316	316	316
15	Strainer	Stainless steel	304	316	904 L
17	Strap	Stainless steel	304	316	904 L
19	Nut for strap	Stainless steel	304	316	904 L
19a	Nut	Stainless steel	316	316	316
20	Motor cable				
78	Nameplate	Stainless steel	316	316	316
Pumps in sleeve					
	Clamping flange (counter)	Stainless steel	304	316	904 L
	Clamping flange	Stainless steel	304	316	904 L
	Connecting piece	Stainless steel	304	316	904 L
	Sleeve	Stainless steel	304	316	904 L
	Stay bolt	Stainless steel	304	316	904 L
	Hexagon socket head screw	Stainless steel	304	316	904 L

Sectional drawing, SP pump, 8"

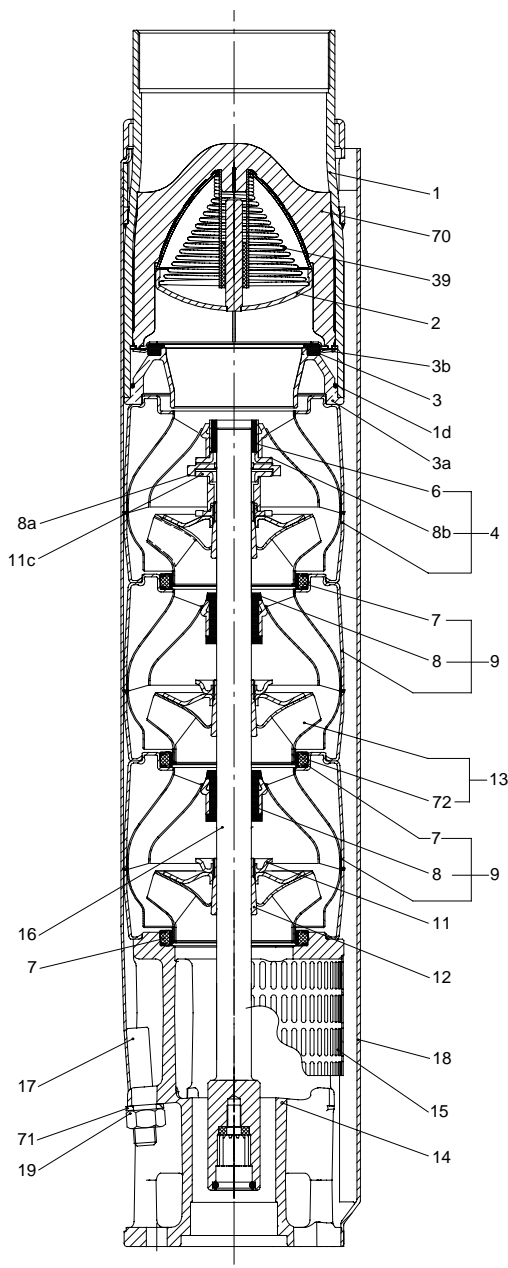

TM01 2359 2301

Fig. 15 SP pump, 8"

Material specification, SP pump, 8"

Pos.	Component	Materials	Standard	N-version	R-version
			AISI		
1	Valve casing	Stainless steel	304	316	904L
1d	O-ring	NBR			
2	Valve cup	Stainless steel	304	316	904L
3	Valve seat	Standard/ N- version: NBR R-version: FKM			
3a	Lower valve seat retainer	Stainless steel	316	316	(DIN 1.4517)
3b	Upper valve seat retainer	Stainless steel	304	316	904L
4	Top chamber	Stainless steel	304	316	904L
6	Upper bearing	Stainless steel/NBR	304	316	904L
7	Neck ring	NBR/PPS			
8	Bearing	NBR			
8a	Washer for stop ring	Carbon/ graphite HY22 in PTFE mass			
8b	Stop ring	Stainless steel	316	316	904L
9	Chamber	Stainless steel	304	316	904L
11	Split cone nut	Stainless steel	304	316	904L
11c	Nut for stop ring	Stainless steel	316	316	904L
12	Split cone	Stainless steel	304	316	904L
13	Impeller	Stainless steel	304	316	904L
14	Suction inter-connector	Stainless steel	CF8M	A744 CD4-MCu	(DIN 1.4517)
15	Strainer	Stainless steel	304	316	904L
16	Shaft complete	Stainless steel	431	329	329
17	Strap	Stainless steel	304	316	904L
18	Cable guard	Stainless steel	304	316	904L
19	Nut for strap	Stainless steel	304	316	904L
39	Spring for valve cup	Stainless steel	304	316	SAF 2205
70	Valve guide	Stainless steel	304	316	904L
71	Washer	Stainless steel	316	316	904L
72	Wear ring	Stainless steel	304	316	904L

Sectional drawing, SP pump, 10"

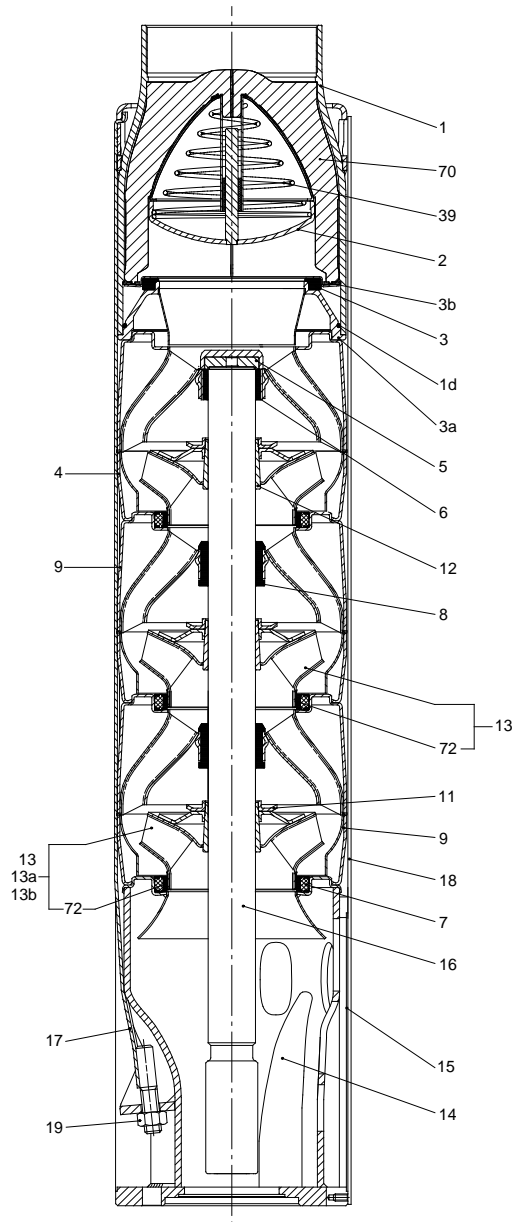

Fig. 16 SP pump, 10"

TM01 2363 2701

Material specification, SP pump, 10"

Pos.	Description	Material	Standard	N version
			AISI	
Valve casing				
1	Valve casing	Stainless steel	304	316
1d	O-ring	NBR		
2	Valve cup	Stainless steel	304	316
3	Valve seat	Stainless steel	304	316
3a	Lower valve seat retainer	Stainless steel	304	316
3b	Upper valve seat retainer	Stainless steel	304	316
39	Spring for valve cup	Stainless steel	301	316
70	Valve guide	Stainless steel	304	316
78	Nameplate	Stainless steel	304	316
79	Rivet	Stainless steel	304	316
63	Connecting piece	Stainless steel	304	316
Chamber stack				
4	Top chamber	Stainless steel	304	316
5	Upthrust disc	Carbon/ graphite HY22 in PTFE mass		
6	Top bearing	Stainless steel/ NBR	304	316
7	Neck ring	NBR/PPS		
8	Bearing	NBR		
9	Chamber	Stainless steel	304	316
11	Nut for split cone	Stainless steel	304	316
12	Split cone	Stainless steel	304	316
13	Impeller	Stainless steel	304	316
16	Shaft with coupling	Stainless steel	431	329
18	Cable guard	Stainless steel	304	316
18a, 18b	Screw for cable guard	Stainless steel	304	316
23	Rubber guard	NBR		
72	Wear ring	Stainless steel	304	316
Suction interconnector				
14	Suction interconnector	Stainless steel	304	316
15	Strainer	Stainless steel	304	316
17	Strap	Stainless steel	304	316
19	Nut for strap	Stainless steel	304	316
19a	Nut	Stainless steel	316	316
20	Motor cable			
22	Bolts	Stainless steel	316	316
28, 28a	Lock for strainer	Stainless steel	329	329

Sectional drawing - MS motors

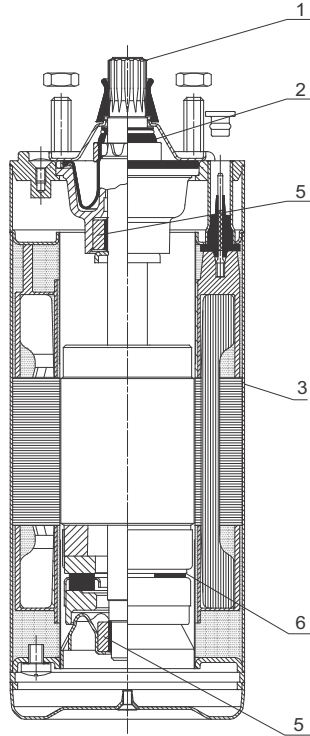

Fig. 17 MS 402 motor

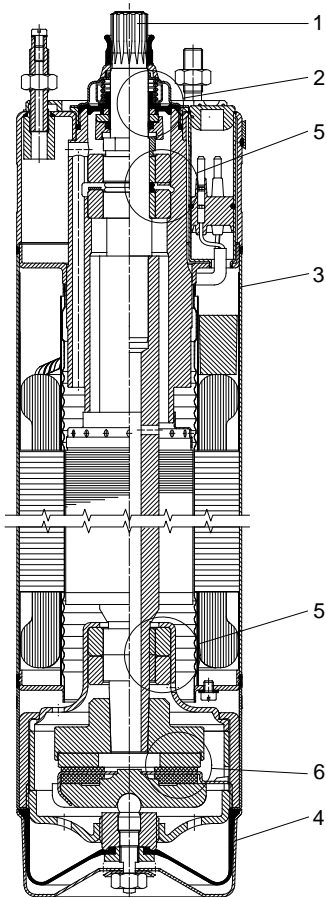

Fig. 18 MS 4000 motor

TM00 4736 0412

TM00 7865 2196

Material specification,
MS 402 and MS 4000 motors

Pos.	Part	MS 402	MS 4000
		AISI	
1	Shaft	431	431
2	Shaft seal	NBR	Tungsten carbide/ ceramic
3	Motor sleeve	304	304
4	Motor end shield		304
5	Radial bearing	Ceramic	Ceramic/ tungsten carbide
6	Axial bearing	Ceramic/carbon	Ceramic/carbon
	Rubber parts	NBR	NBR

R-version motor

Pos.	Part	MS 4000
1	Shaft	318 LN
2	Shaft seal	NBR/ceramic
3	Motor sleeve	904L
4	Motor end shield	904L
5	Radial bearing	Ceramic/tungsten carbide
6	Thrust bearing	Ceramic/carbon
	Rubber parts	NBR

Sectional drawing - MS6 motors

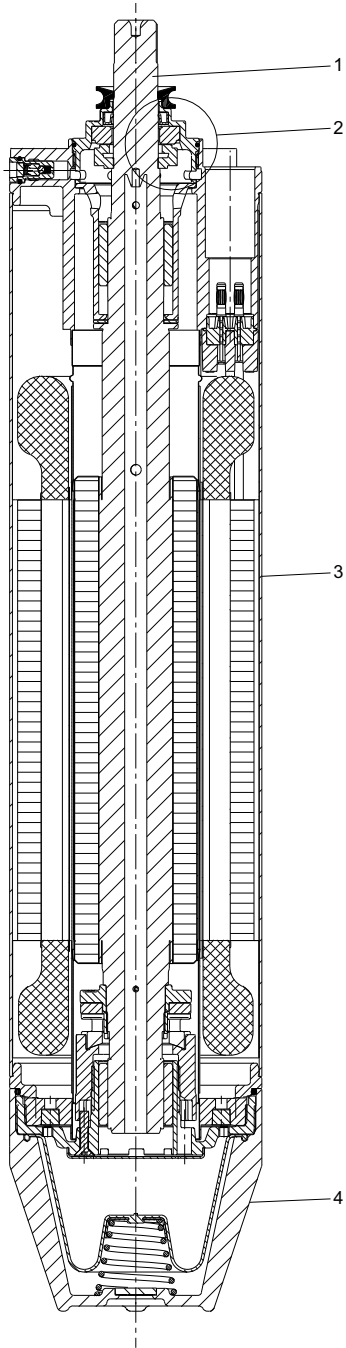

Fig. 19 MS6 motor

TM03 9226 3607

Material specification - MS6 motors

Pos.	Part	MS6
202	Shaft with rotor	318LN
2	Shaft seal	Ceramic/carbon
3	Motor sleeve	304
4	Motor end cover	304
Rubber parts		NBR/FKM

R-version motor

Pos.	Part	MS6
1	Shaft	318LN
2	Shaft seal	SiC/SiC
3	Motor sleeve	904L
4	Motor end cover	(DIN 1.4517)
Rubber parts		FKM

Sectional drawing - MMS motors

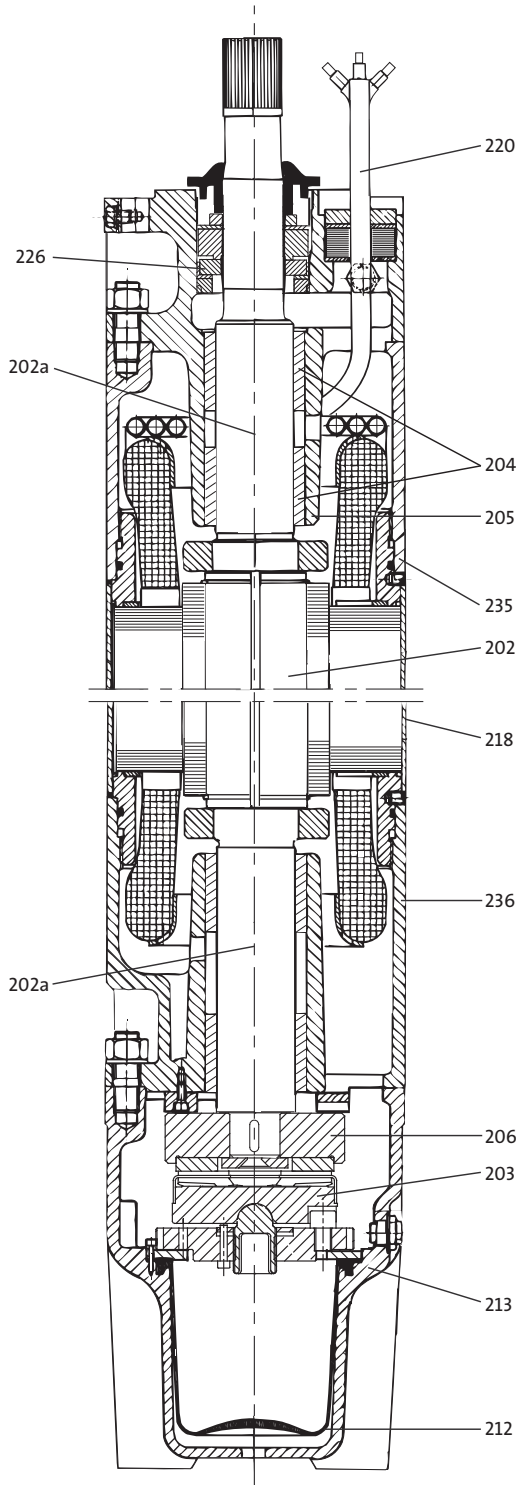

TM01 4985 0404

Fig. 20 MMS 10000

Material specification

MMS motors, submersible rewindable versions

Pos.	Component		Material	AISI
202	Shaft		Steel	(EN 1.0533)
202a	Shaft ends		Stainless steel	316/329
203/ 206	Thrust bearing Stationary/ rotating part	6", 0.5 - 20 Hp	Hardened steel/ EPDM	
		6", 25 - 50 Hp		
		8" - 10"		
204	Bearing bush	6" - 10"	Carbon	
205	Bearing housing, upper		Cast iron	A126 Class B
212	Diaphragm		CR	
213	Motor end shield		Cast iron	A126 Class B
218	Motor sleeve		Stainless steel	304
220	Motor cable		EPDM	
226	Shaft seal		Ceramic/ carbon	
235	Intermediate housing		Cast iron	A126 Class B
236	Bearing housing, lower		Cast iron	A126 Class B

MMS motors, N- and R-versions

Pos.	Component		Material	Version	
				N	R*
				AISI	
202	Shaft		Steel	(EN 1.0533)	(EN 1.0533)
202a	Shaft ends		Stainless steel	316/329	318LN
203/ 206	Thrust bearing Stationary/ rotating part	6", 0.5 - 20 Hp	Hardened steel/EPDM		
		6", 25 - 50 Hp			
		8"-10"			
204	Bearing bush	6"-10"	Carbon		
205	Bearing housing, upper		Stainless steel	316	904L
212	Diaphragm		CR		
213	Motor end shield		Stainless steel	316	904L
218	Motor sleeve		Stainless steel	316	904L
220	Motor cable		EPDM		
226	Shaft seal		Ceramic/ carbon		
235	Intermediate housing		Stainless steel	316	904L
236	Bearing housing, lower		Stainless steel	316	904L

* Only MMS 6000 and MMS 8000 are available in R-versions

4. Operating conditions

Operating conditions

Flow rate, Q: 0.44 - 1475 gpm (0.1-335 m³/h).

Head, H: Maximum 2657 ft (810 m).

Maximum liquid temperature

Motor	Installation		
	Flow velocity past motor	Vertical [°F (°C)]	Horizontal [°F (°C)]
Grundfos MS 4" and MS6 T30-versions	0.49 ft/s (0.15 m/s)	86 (30)	86 (30)
Grundfos 4" MS industry versions	0.49 ft/s (0.15 m/s)	140 (60)	140 (60)
Grundfos MS6 T60-versions	3.28 ft/s (1.0 m/s)	140 (60)	140 (60)
Grundfos MMS 6" to 12" rewindable with PVC in the windings	0.49 ft/s (0.15 m/s)	77 (25)	77 (25)
	1.64 ft/s (0.50 m/s)	86 (30)	86 (30)
Grundfos MMS 6" to 12" rewindable with PE/PA in the windings	0.49 ft/s (0.15 m/s)	104 (40)	104 (40)
	1.64 ft/s (0.50 m/s)	113 (45)	113 (45)

Note: Note: For MMS 6000, 0.5 hp; MMS 8000, 150 hp; the maximum liquid temperature is 9 °F (5 °C) lower than the values stated in the table. For MMS 10000, 250 hp, the temperature is 18 °F (10 °C) lower.

Operating pressure

Motor	Maximum operating pressure
Grundfos MS 4" and 6"	870 psi (6 Mpa) (60 bar)
Grundfos MMS 6" to 10" rewindable	

Curve conditions

The conditions below apply to the curves shown on pages 20 - 84:

General

- Curve tolerances according to ISO 9906, Annex A.
- The performance curves show pump performance at actual speed, cf. standard motor range. The speeds of the motors are approximately these:
 - 4" motors: n = 3470 min⁻¹
 - 6" motors: n = 3460 min⁻¹
 - 8" to 10" motors: n = 3525 min⁻¹
- The measurements were made with airless water at a temperature of 68 °F (20 °C). The curves apply to a kinematic viscosity of 1 mm²/s (1 cSt). When pumping liquids with a density higher than that of water, use motors with correspondingly higher outputs.
- The **bold** curves indicate the recommended performance range.
- The performance curves are inclusive of possible losses such as non-return valve loss.
- **Q/H:** The curves are inclusive of valve and inlet losses at the actual speed. Operation without non-return valve will increase the actual head at rated performance by 0.5 to 1.0 m.
- **NPSH:** The curve is inclusive of pressure loss in the suction interconnector and shows required inlet pressure.
- **Power curve:** P₂ shows pump power input at the actual speed of each individual pump size.
- **Efficiency curve:** Eta shows pump stage efficiency. If Eta for the actual pump size is needed, please consult WinCAPS or WebCAPS.

5. How to read the curve charts

Number of stages.
First figure: number of stages;
second figure: number of
reduced-diameter impellers.

The efficiency curve shows
the efficiency of the pump.
The efficiency curve is an
average curve of all the pump
types shown in the chart.
The efficiency of pumps with
reduced-diameter impellers is
approx. 2 % lower than the
efficiency curve shown in the
chart.

Pump type, number of poles
and frequency.

QH curve for the individual
pump. The **bold** curves
indicate the **recommended**
performance range for best
efficiency.

The power curves indicate
pump input power **per stage**.
Curves are shown for
complete (1/1) and for
reduced-diameter (2/3)
impellers.

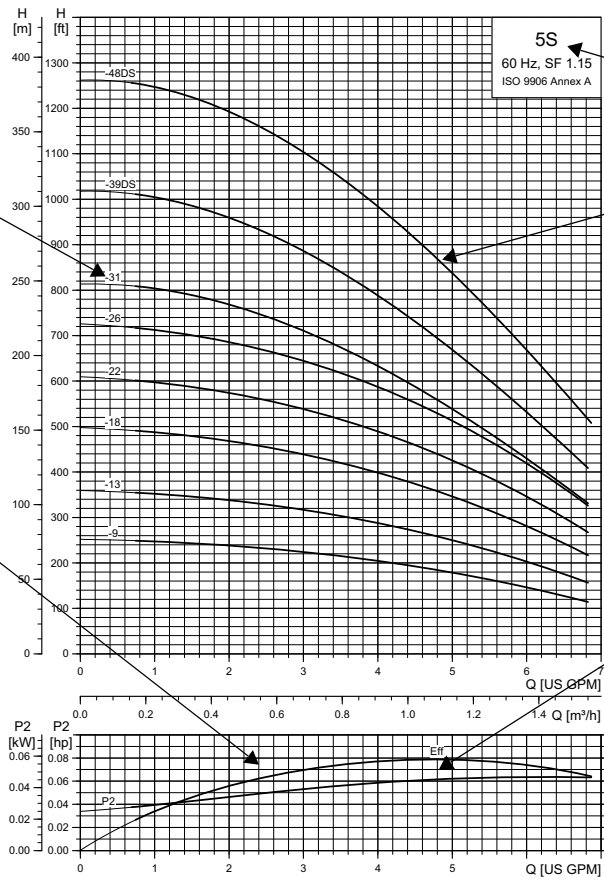

TM05 0229 10112

6. Curve charts and technical data

5S (5 gpm)

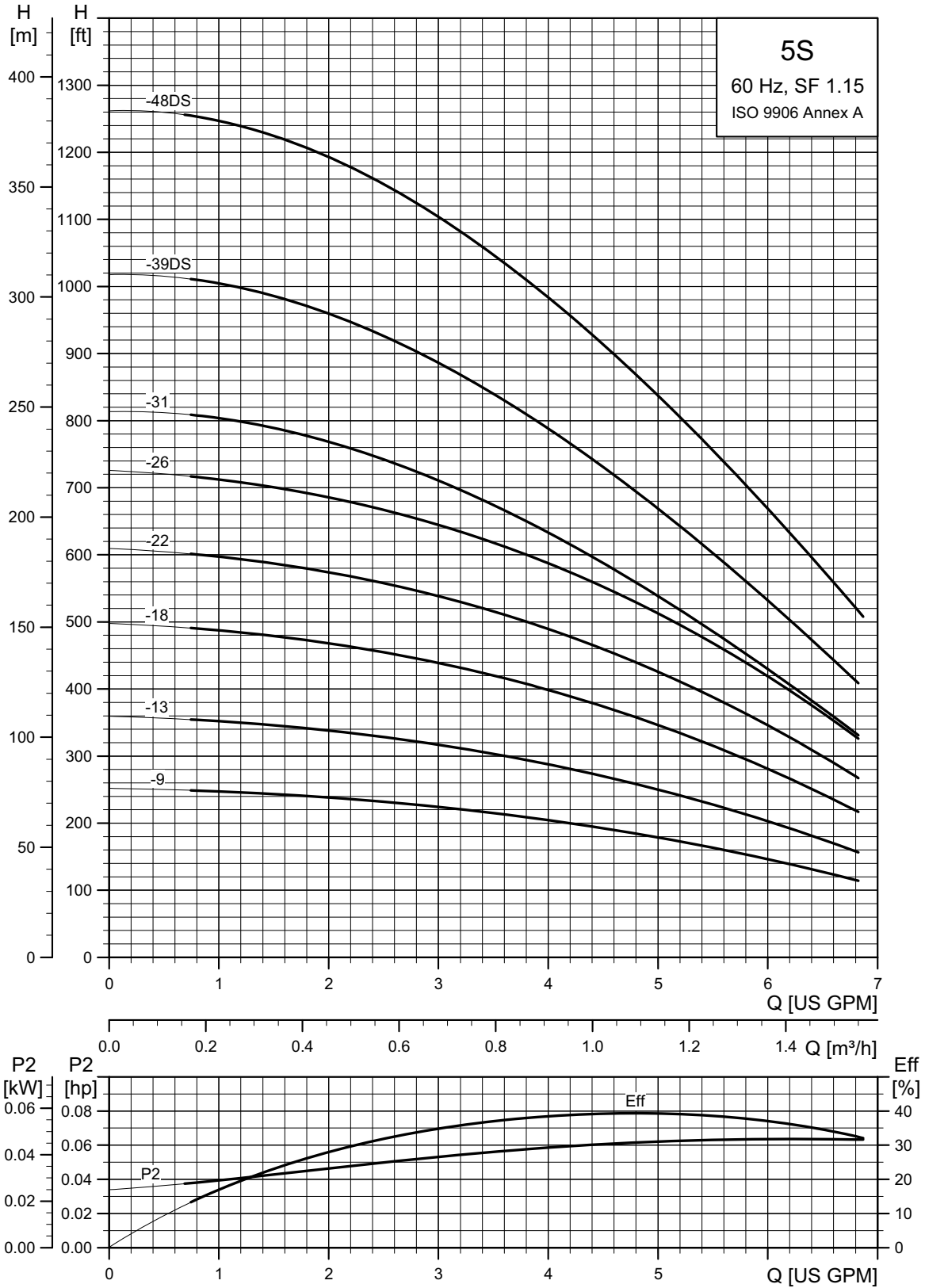

TN05 0229 0112

5S (5 gpm)

Pump model	Nom. head [ft]	Ph	Volts [V]	Motor [Hp]	Dimensions					Net weight (complete) [lb]	
					A	B	C	D	E		
					[in (mm)]	[in (mm)]	[in (mm)]	[in (mm)]	[in (mm)]		
5S, motor dia. 4 inch, 2 wire motor, 60 Hz - rated flow 5 gpm (1" NPT)											
5S05-9	171	1	230	0.5	■ 24.57 (624)	11.03 (280)	13.55 (344)	3.74 (95)	3.97 (101)	21.6	
5S05-13	247	1	115	0.5	■ 27.88 (708)	11.03 (280)	16.86 (428)	3.74 (95)	3.97 (101)	26.9	
			230	0.5	■ 27.88 (708)	11.03 (280)	16.86 (428)	3.74 (95)	3.97 (101)	26.1	
5S07-18	343	1	230	0.75	■ 32.60 (828)	11.62 (295)	20.99 (533)	3.74 (95)	3.97 (101)	29.7	
5S10-22	419	1	230	1	■ 36.50 (927)	12.21 (310)	24.30 (617)	3.74 (95)	3.97 (101)	32.4	
5S15-26	495	1	230	1.5	■ 41.30 (1049)	13.71 (348)	27.60 (701)	3.74 (95)	3.97 (101)	41.4	
5S15-31	527	1	230	1.5	■ 47.21 (1199)	13.71 (348)	33.51 (851)	3.74 (95)	3.97 (101)	47.7	
5S, motor dia. 4 inch, 3 wire motor, 60 Hz - rated flow 5 gpm (1" NPT)											
5S05-9	171	1	230	0.5	■ 24.57 (624)	11.03 (280)	13.55 (344)	3.74 (95)	3.97 (101)	22.5	
5S05-13	247	1	115	0.5	■ 27.88 (708)	11.03 (280)	16.86 (428)	3.74 (95)	3.97 (101)	26.9	
			230	0.5	■ 27.88 (708)	11.03 (280)	16.86 (428)	3.74 (95)	3.97 (101)	25.2	
5S07-18	343	1	230	0.75	■ 32.60 (828)	11.62 (295)	20.99 (533)	3.74 (95)	3.97 (101)	28.8	
5S10-22	419	1	230	1	■ 36.50 (927)	12.21 (310)	24.30 (617)	3.74 (95)	3.97 (101)	32.4	
5S15-26	495	3	1	230	1.5	■ 41.30 (1049)	13.71 (348)	27.60 (701)	3.74 (95)	3.97 (101)	37.8
			230	1.5	■ 39.81 (1011)	12.21 (310)	27.60 (701)	3.74 (95)	3.97 (101)	38.7	
			460	1.5	■ 39.81 (1011)	12.21 (310)	27.60 (701)	3.74 (95)	3.97 (101)	38.7	
5S15-31	527	3	1	230	1.5	■ 47.21 (1199)	13.71 (348)	33.51 (851)	3.74 (95)	3.97 (101)	47.7
			230	1.5	■ 45.71 (1161)	12.21 (310)	33.51 (851)	3.74 (95)	3.97 (101)	45.0	
			460	1.5	■ 45.71 (1161)	12.21 (310)	33.51 (851)	3.74 (95)	3.97 (101)	45.0	
5S20-39DS	663	3	1	230	2	● 59.61 (1514)	19.49 (495)	40.12 (1019)	3.74 (95)	3.97 (101)	57.6
			230	2	■ 53.82 (1367)	13.71 (348)	40.12 (1019)	3.74 (95)	3.97 (101)	54.0	
			460	2	■ 53.82 (1367)	13.71 (348)	40.12 (1019)	3.74 (95)	3.97 (101)	54.0	
5S30-48DS	816	3	1	230	3	● 70.16 (1782)	22.60 (574)	47.56 (1208)	3.74 (95)	3.97 (101)	77.4
			230	3	● 65.56 (1665)	18.00 (457)	47.56 (1208)	3.74 (95)	3.97 (101)	77.4	
			460	3	● 65.56 (1665)	18.00 (457)	47.56 (1208)	3.74 (95)	3.97 (101)	77.4	

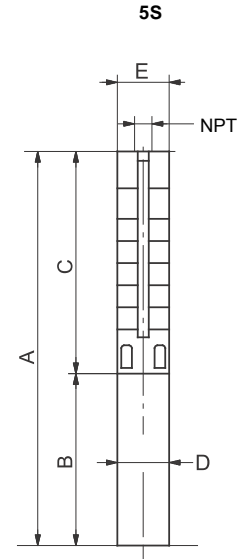

TM05 0204 0711

E = Maximum diameter of pump including cable guard and motor.

- Notes:
 Control box is required for 3-wire, single-phase applications. Data does not include control box.
 DS designation = Built into sleeve, 1-1/4" NPT, 6" minimum well diameter.
- MS402 motor.
 - MS4000 motor.
 - ▲ MS6 motor.
 - △ MMS6000 motor.
 - ★ MMS8000 motor.
 - ◆ Takes MS6 motor; not available as complete.
 - ☆ Takes MMS6000 motor; not available as complete.
 - * Takes MMS8000 motor; not available as complete.
 - † Takes MMS10000 motor; not available as complete.

7S (7 gpm)

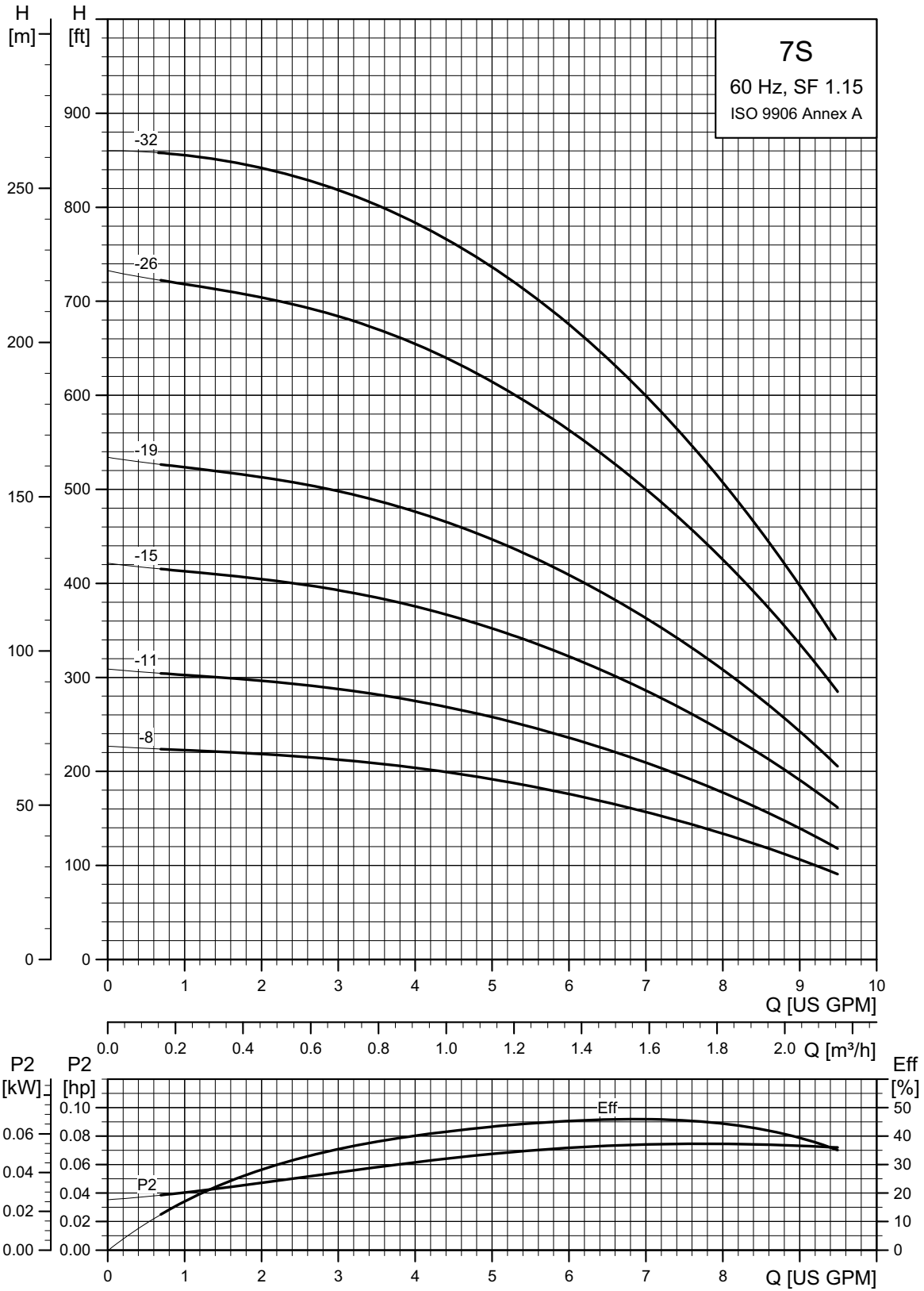

TM05 0982 0112

7S (7 gpm)

Pump model	Nom. head [ft]	Ph	Volts [V]	Motor [Hp]	Dimensions					Net weight (complete) [lb]
					A [in (mm)]	B [in (mm)]	C [in (mm)]	D [in (mm)]	E [in (mm)]	
7S, motor dia. 4 inch, 2 wire motor, 60 Hz - rated flow 7 gpm (1" NPT)										
7S05-8	151	1	230	.5 ■	23.75 (603)	11.03 (280)	12.72 (323)	3.74 (95)	3.97 (101)	21.6
7S05-11	208	1	115	.5 ■	26.23 (666)	11.03 (280)	15.20 (386)	3.74 (95)	3.97 (101)	29.7
			230	.5 ■	26.23 (666)	11.03 (280)	15.20 (386)	3.74 (95)	3.97 (101)	24.3
7S07-15	283	1	230	.75 ■	30.12 (765)	11.62 (295)	18.51 (470)	3.74 (95)	3.97 (101)	29.7
7S10-19	358	1	230	1 ■	34.02 (864)	12.21 (310)	21.82 (554)	3.74 (95)	3.97 (101)	32.4
7S15-26	491	1	230	1.5 ■	41.3 (1049)	13.71 (348)	27.60 (701)	3.74 (95)	3.97 (101)	41.4
7S, motor dia. 4 inch, 3 wire motor, 60 Hz - rated flow 7 gpm (1" NPT)										
7S05-8	151	1	230	.5 ■	23.75 (603)	11.03 (280)	12.72 (323)	3.74 (95)	3.97 (101)	21.6
7S05-11	208	1	115	.5 ■	26.23 (666)	11.03 (280)	15.20 (386)	3.74 (95)	3.97 (101)	21.6
			230	.5 ■	26.23 (666)	11.03 (280)	15.20 (386)	3.74 (95)	3.97 (101)	30.6
7S07-15	283	1	230	.75 ■	30.12 (765)	11.62 (295)	18.51 (470)	3.74 (95)	3.97 (101)	27.9
7S10-19	358	1	230	1 ■	34.02 (864)	12.21 (310)	21.82 (554)	3.74 (95)	3.97 (101)	39.6
7S15-26	491	3	230	1.5 ■	41.30 (1049)	13.71 (348)	27.60 (701)	3.74 (95)	3.97 (101)	38.7
			460	1.5 ■	39.81 (1011)	12.21 (310)	27.60 (701)	3.74 (95)	3.97 (101)	38.7
7S20-32	604	3	230	2 ●	52.05 (1322)	19.49 (495)	32.56 (827)	3.74 (95)	3.97 (101)	48.5
			460	2 ■	46.26 (1175)	13.71 (348)	32.56 (827)	3.74 (95)	3.97 (101)	48.5

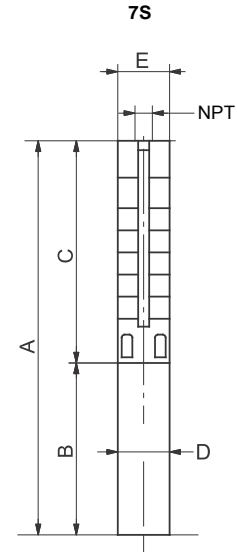

TM05 0204 0711

E = Maximum diameter of pump including cable guard and motor.

Notes:

Control box is required for 3-wire, single-phase applications. Data does not include control box.

- MS402 motor.
- MS4000 motor.
- ▲ MS6 motor.
- △ MMS6000 motor.
- ★ MMS8000 motor.
- ◆ Takes MS6 motor; not available as complete.
- ⊛ Takes MMS6000 motor; not available as complete.
- * Takes MMS8000 motor; not available as complete.
- † Takes MMS10000 motor; not available as complete.

10S (10 gpm)

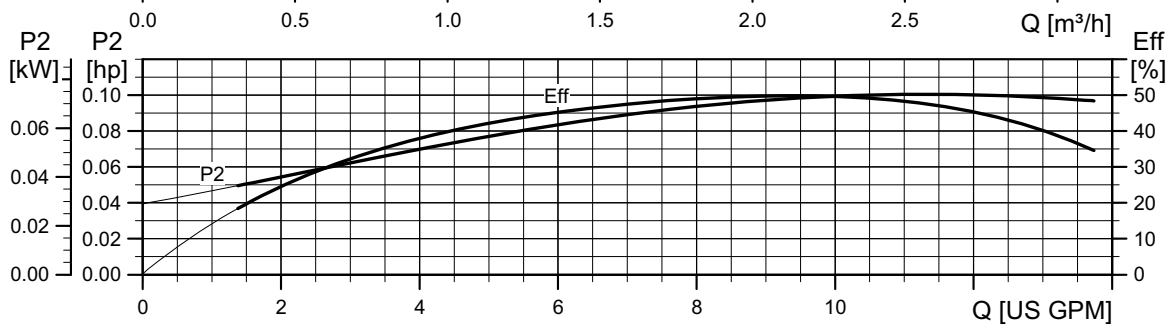
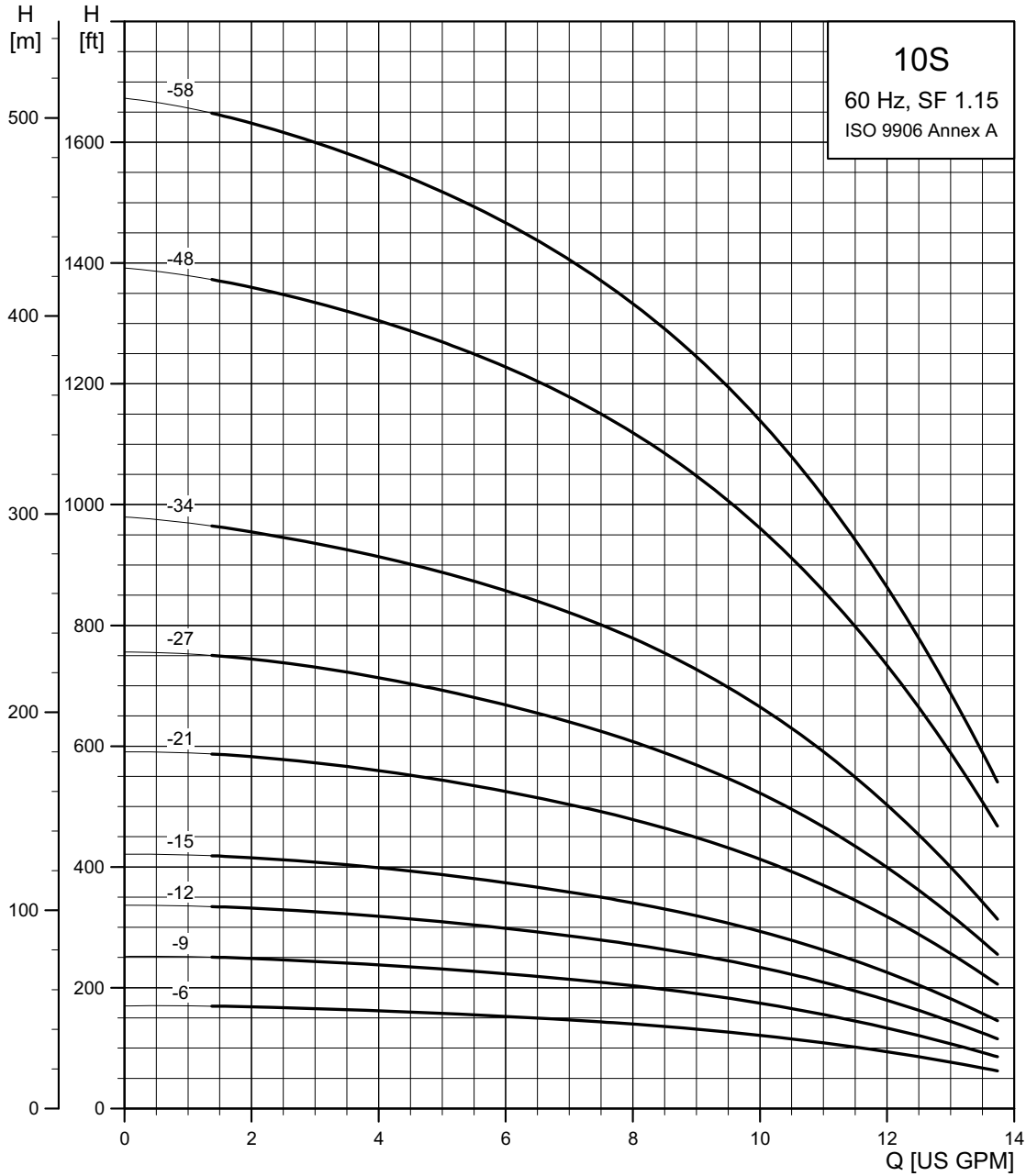

TM05 0230 0112

10S (10 gpm)

Pump model	Nom. head [ft]	Ph	Volts [V]	Motor [Hp]	Dimensions					Net weight (complete) [lb]
					A [in (mm)]	B [in (mm)]	C [in (mm)]	D [in (mm)]	E [in (mm)]	
10S, motor dia. 4 inch, 2 wire motor, 60 Hz - rated flow 10 gpm (1.25" NPT)										
10S05-6	116	1	230	.5 ■	22.05 (560)	10.99 (279)	11.07 (281)	3.74 (95)	3.97 (101)	20.7
10S05-9	174	1	115	.5 ■	24.53 (623)	10.99 (279)	13.55 (344)	3.74 (95)	3.97 (101)	24.3
			230	.5 ■	24.53 (623)	10.99 (279)	13.55 (344)	3.74 (95)	3.97 (101)	23.4
10S07-12	233	1	230	.75 ■	27.60 (701)	11.58 (294)	16.03 (407)	3.74 (95)	3.97 (101)	24.3
10S10-15	291	1	230	1 ■	30.67 (779)	12.17 (309)	18.51 (470)	3.74 (95)	3.97 (101)	29.7
10S15-21	407	1	230	1.5 ■	37.17 (944)	13.71 (348)	23.47 (596)	3.74 (95)	3.97 (101)	35.1
10S, motor dia. 4 inch, 3 wire motor, 60 Hz - rated flow 10 gpm (1.25" NPT)										
10S05-6	116	1	230	.5 ■	24.77 (629)	13.71 (348)	11.07 (281)	3.74 (95)	3.97 (101)	21.6
10S05-9	174	1	115	.5 ■	24.53 (623)	10.99 (279)	13.55 (344)	3.74 (95)	3.97 (101)	25.4
			230	.5 ■	24.53 (623)	10.99 (279)	13.55 (344)	3.74 (95)	3.97 (101)	24.3
10S07-12	233	1	230	.75 ■	27.60 (701)	11.58 (294)	16.03 (407)	3.74 (95)	3.97 (101)	28.8
10S10-15	291	1	230	1 ■	30.67 (779)	12.17 (309)	18.51 (470)	3.74 (95)	3.97 (101)	29.7
10S15-21	407	1	230	1.5 ■	37.17 (944)	13.71 (348)	23.47 (596)	3.74 (95)	3.97 (101)	35.1
		3	230	1.5 ■	35.63 (905)	12.17 (309)	23.47 (596)	3.74 (95)	3.97 (101)	32.4
10S20-27	524	1	230	2 ●	47.92 (1217)	19.49 (495)	28.43 (722)	3.74 (95)	3.97 (101)	45.9
		3	230	2 ■	42.13 (1070)	13.71 (348)	28.43 (722)	3.74 (95)	3.97 (101)	44.1
10S30-34	659	1	230	3 ●	58.59 (1488)	22.6 (574)	35.99 (914)	3.74 (95)	3.97 (101)	81.9
		3	230	3 ●	53.98 (1371)	18.00 (457)	35.99 (914)	3.74 (95)	3.97 (101)	74.7
10S50-48DS	931	1	230	5 ●	74.18 (1884)	26.62 (676)	47.56 (1208)	3.74 (95)	3.97 (101)	103.5
		3	230	5 ●	70.16 (1782)	22.60 (574)	47.56 (1208)	3.74 (95)	3.97 (101)	103.5
10S50-58DS	1124	1	230	5 ●	89.49 (2272)	26.62 (676)	62.88 (1597)	3.74 (95)	4.25 (108)	132.3
		3	230	5 ●	85.48 (2171)	22.60 (574)	62.88 (1597)	3.74 (95)	4.25 (108)	132.3

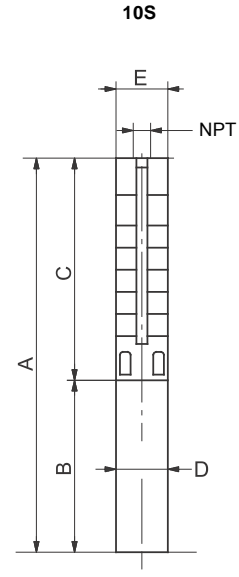

TM05 0204 0711

E = Maximum diameter of pump including cable guard and motor.

- Notes:
 Control box is required for 3-wire, single-phase applications. Data does not include control box.
 DS designation = Built into sleeve, 1-1/4" NPT, 6" minimum well diameter.
- MS402 motor.
 - MS4000 motor.
 - ▲ MS6 motor.
 - △ MMS6000 motor.
 - ★ MMS8000 motor.
 - ◆ Takes MS6 motor; not available as complete.
 - ☆ Takes MMS6000 motor; not available as complete.
 - * Takes MMS8000 motor; not available as complete.
 - † Takes MMS10000 motor; not available as complete.

16S (16 gpm)

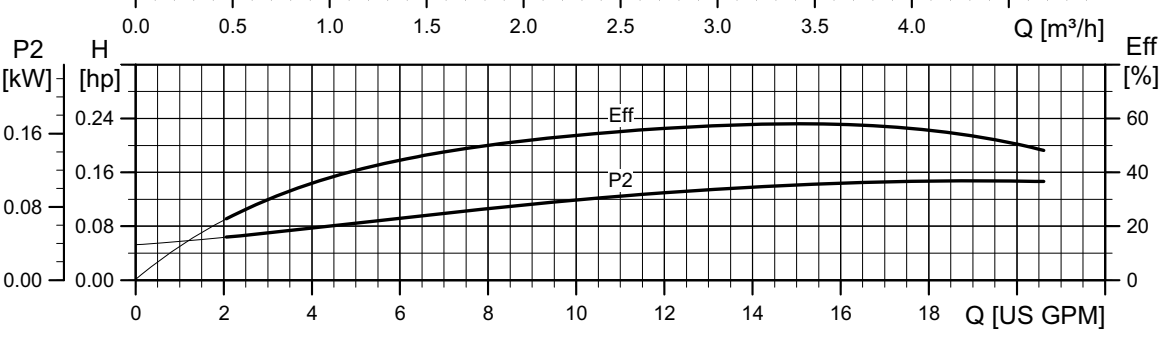
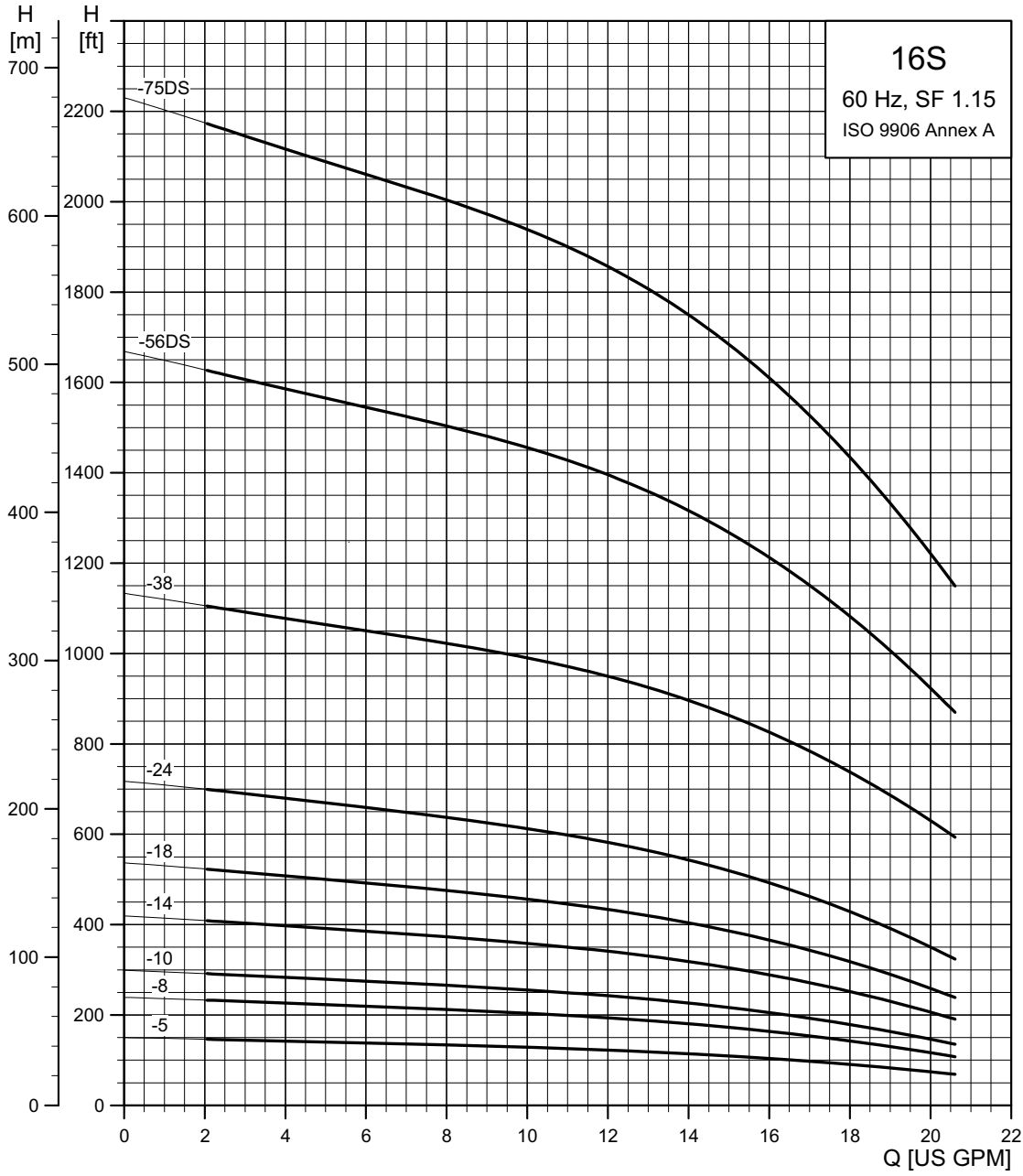

TM05 0231 0112

16S (16 gpm)

Pump model	Nom. head [ft]	Ph	Volts [V]	Motor [Hp]	Dimensions					Net weight (complete) [lb]	
					A [in (mm)]	B [in (mm)]	C [in (mm)]	D [in (mm)]	E [in (mm)]		
16S, motor dia. 4 inch, 2 wire motor, 60 Hz - rated flow 16 gpm (1.25" NPT)											
16S05-5	102	1	115	.5	■	21.26 (540)	11.03 (280)	10.24 (260)	3.74 (95)	3.97 (101)	21.6
			230	.5	■	21.26 (540)	11.03 (280)	10.24 (260)	3.74 (95)	3.97 (101)	23.4
16S07-8	162	1	230	.75	■	24.34 (618)	11.62 (295)	12.72 (323)	3.74 (95)	3.97 (101)	24.3
16S10-10	203	1	230	1	■	26.58 (675)	12.21 (310)	14.38 (365)	3.74 (95)	3.97 (101)	27.9
16S15-14	284	1	230	1.5	■	31.38 (797)	13.71 (348)	17.68 (449)	3.74 (95)	3.97 (101)	36.0
16S, motor dia. 4 inch, 3 wire motor, 60 Hz - rated flow 16 gpm (1.25" NPT)											
16S05-5	102	1	115	.5	■	21.26 (540)	11.03 (280)	10.24 (260)	3.74 (95)	3.97 (101)	21.6
			230	.5	■	21.26 (540)	11.03 (280)	10.24 (260)	3.74 (95)	3.97 (101)	21.6
16S07-8	162	1	230	.75	■	24.34 (618)	11.62 (295)	12.72 (323)	3.74 (95)	3.97 (101)	27.0
16S10-10	203	1	230	1	■	26.58 (675)	12.21 (310)	14.38 (365)	3.74 (95)	3.97 (101)	27.9
			230	1.5	●	31.38 (797)	13.71 (348)	17.68 (449)	3.74 (95)	3.97 (101)	32.4
16S15-14	284	3	230	1.5	■	29.89 (759)	12.21 (310)	17.68 (449)	3.74 (95)	3.97 (101)	28.8
			460	1.5	■	29.89 (759)	12.21 (310)	17.68 (449)	3.74 (95)	3.97 (101)	28.8
16S20-18	366	3	230	2	●	40.48 (1028)	19.49 (495)	20.99 (533)	3.74 (95)	3.97 (101)	36.0
			460	2	■	34.69 (881)	13.71 (348)	20.99 (533)	3.74 (95)	3.97 (101)	36.0
16S30-24	487	3	230	3	●	48.55 (1233)	22.60 (574)	25.95 (659)	3.74 (95)	3.97 (101)	62.1
			460	3	●	43.94 (1116)	18.00 (457)	25.95 (659)	3.74 (95)	3.97 (101)	57.6
16S50-38	814	3	230	5	●	65.91 (1674)	26.62 (676)	39.30 (998)	3.74 (95)	3.97 (101)	97.2
			460	5	●	62.01 (1575)	22.72 (577)	39.30 (998)	3.74 (95)	3.97 (101)	90.0
SP 16S, motor dia. 6 inch, 3 wire motor, 60 Hz - rated flow 16 gpm (1.25" NPT)											
16S75-56DS	1200	3	230	7.5	▲	95.40 (2423)	26.62 (676)	68.78 (1747)	5.63 (143)	5.51 (140)	165.1
			460	7.5	▲	95.40 (2423)	26.62 (676)	68.78 (1747)	5.63 (143)	5.51 (140)	165.1
16S100-75DS	1607	3	460	10	▲	115.08 (2923)	30.60 (777)	84.49 (2146)	5.63 (143)	5.51 (140)	190.0

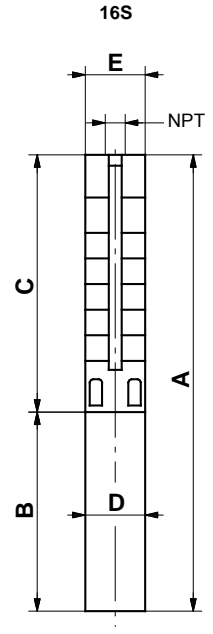

TM00 8521 3196

E = Maximum diameter of pump including cable guard and motor.

Notes:

Control box is required for 3-wire, single-phase applications. Data does not include control box.
 DS designation = Built into sleeve, 1-1/4" NPT, 6" minimum well diameter.

- MS402 motor.
- MS4000 motor.
- ▲ MS6 motor.
- △ MMS6000 motor.
- ★ MMS8000 motor.
- ◆ Takes MS6 motor; not available as complete.
- ⊛ Takes MMS6000 motor; not available as complete.
- * Takes MMS8000 motor; not available as complete.
- † Takes MMS10000 motor; not available as complete.

25S (25 gpm)

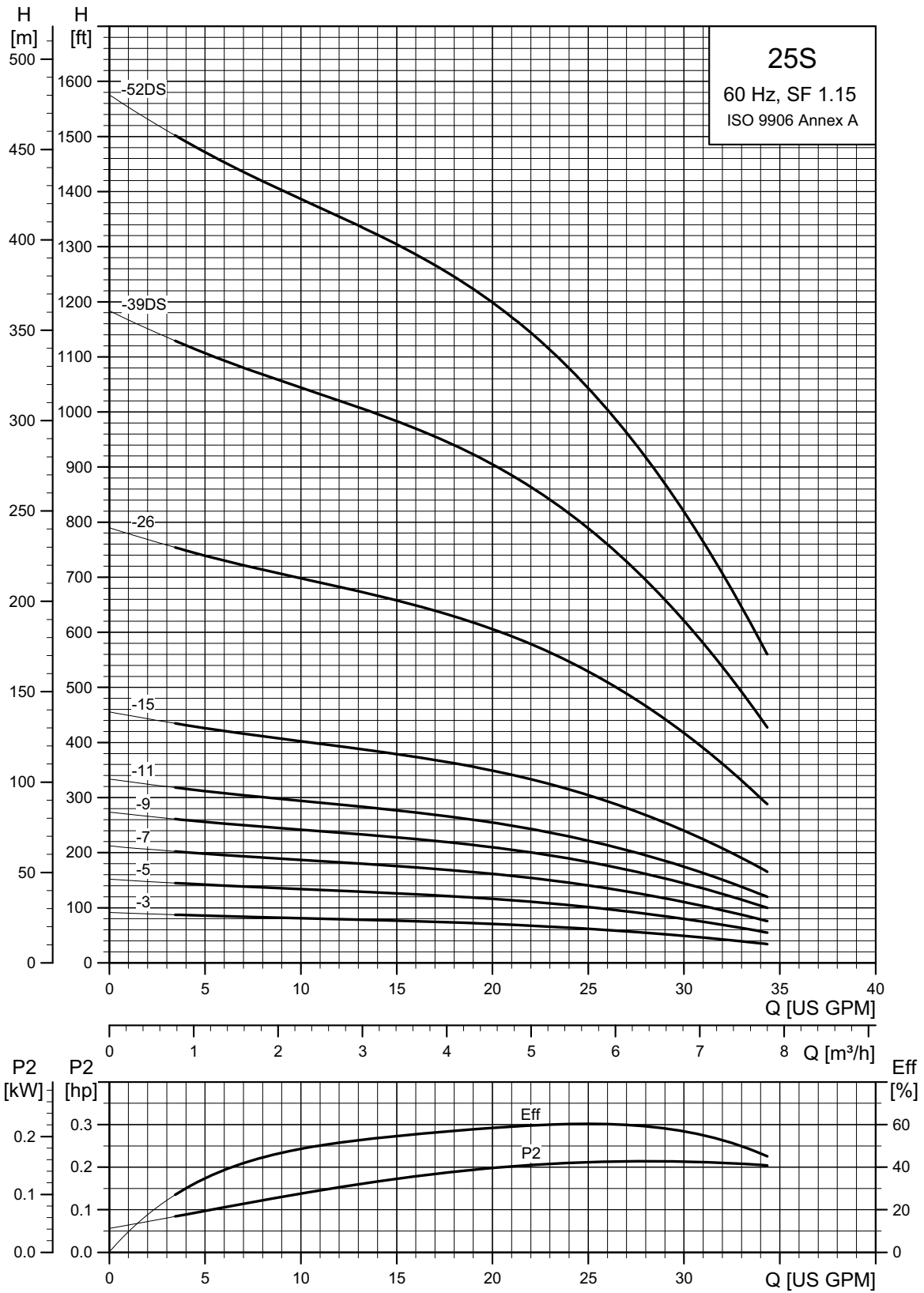

TM05 0232 0112

25S (25 gpm)

Pump model	Nom. head [ft]	Ph	Volts [V]	Motor [Hp]	Dimensions					Net weight (complete) [lb]	
					A [in (mm)]	B [in (mm)]	C [in (mm)]	D [in (mm)]	E [in (mm)]		
25S, motor dia. 4 inch, 2 wire motor, 60 Hz - rated flow 25 gpm (1.5" NPT)											
25S05-3	60	1	115	.5	■	19.61 (498)	11.03 (280)	8.59 (218)	3.74 (95)	3.97 (101)	21.6
			230	.5	■	19.61 (498)	11.03 (280)	8.59 (218)	3.74 (95)	3.97 (101)	21.6
25S07-5	99	1	230	.75	■	21.86 (555)	11.62 (295)	10.24 (260)	3.74 (95)	3.97 (101)	23.4
25S10-7	139	1	230	1	■	24.10 (612)	12.21 (310)	11.89 (302)	3.74 (95)	3.97 (101)	25.2
25S15-9	179	1	230	1.5	■	27.25 (692)	13.71 (348)	13.55 (344)	3.74 (95)	3.97 (101)	28.8
25S, motor dia. 4 inch, 3 wire motor, 60 Hz - rated flow 25 gpm (1.5" NPT)											
25S05-3	60	1	115	.5	■	19.61 (498)	11.03 (280)	8.59 (218)	3.74 (95)	3.97 (101)	21.6
			230	.5	■	19.61 (498)	11.03 (280)	8.59 (218)	3.74 (95)	3.97 (101)	21.6
25S07-5	99	1	230	.75	■	21.86 (555)	11.62 (295)	10.24 (260)	3.74 (95)	3.97 (101)	23.4
25S10-7	139	1	230	1	■	24.10 (612)	12.21 (310)	11.89 (302)	3.74 (95)	3.97 (101)	25.2
			230	1.5	■	27.25 (692)	13.71 (348)	13.55 (344)	3.74 (95)	3.97 (101)	29.7
25S15-9	179	3	230	1.5	■	25.75 (654)	12.21 (310)	13.55 (344)	3.74 (95)	3.97 (101)	27.0
			460	1.5	■	25.75 (654)	12.21 (310)	13.55 (344)	3.74 (95)	3.97 (101)	28.8
25S20-11	219	3	230	2	■	34.69 (881)	19.49 (495)	15.20 (386)	3.74 (95)	3.97 (101)	33.1
			230	2	■	28.90 (734)	13.71 (348)	15.20 (386)	3.74 (95)	3.97 (101)	37.0
25S30-15	298	3	230	2	■	28.90 (734)	13.71 (348)	15.20 (386)	3.74 (95)	3.97 (101)	33.3
			460	2	■	28.90 (734)	13.71 (348)	15.20 (386)	3.74 (95)	3.97 (101)	33.3
25S30-15	298	3	230	3	●	41.11 (1044)	22.60 (574)	18.51 (470)	3.74 (95)	3.97 (101)	61.2
			460	3	●	36.50 (927)	18.00 (457)	18.51 (470)	3.74 (95)	3.97 (101)	53.1
25S50-26	517	3	230	3	●	36.50 (927)	18.00 (457)	18.51 (470)	3.74 (95)	3.97 (101)	53.1
			460	3	●	36.50 (927)	18.00 (457)	18.51 (470)	3.74 (95)	3.97 (101)	53.1
25S50-26	517	3	230	5	●	54.22 (1377)	26.62 (676)	27.60 (701)	3.74 (95)	3.97 (101)	72.9
			460	5	●	50.32 (1278)	22.72 (577)	27.60 (701)	3.74 (95)	3.97 (101)	72.9
25S50-26	517	3	230	5	●	50.32 (1278)	22.72 (577)	27.60 (701)	3.74 (95)	3.97 (101)	72.9
			460	5	●	50.32 (1278)	22.72 (577)	27.60 (701)	3.74 (95)	3.97 (101)	72.9
SP 25S, motor dia. 6 inch, 3 wire motor, 60 Hz - rated flow 25 gpm (1.5" NPT)											
25S75-39DS	775	3	230	7.5	▲	64.81 (1646)	22.25 (565)	42.56 (1081)	5.63 (143)	5.43 (138)	122.1
			460	7.5	▲	64.81 (1646)	22.25 (565)	42.56 (1081)	5.63 (143)	5.43 (138)	122.1
25S100-52DS	1034	3	460	10	▲	88.71 (2253)	23.23 (590)	65.48 (1663)	5.63 (143)	5.51 (140)	163.1

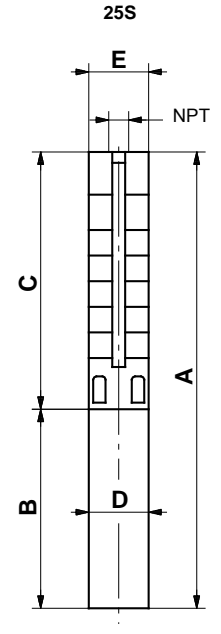

TM00 8521 3196

E = Maximum diameter of pump including cable guard and motor.

Notes:
 Control box is required for 3-wire, single-phase applications. Data does not include control box.
 DS designation = Built into sleeve, 1-1/2" NPT, 6" minimum well diameter.
 ■ MS402 motor.
 ● MS4000 motor.
 ▲ MS6 motor.
 △ MMS6000 motor.
 ★ MMS8000 motor.
 ◆ Takes MS6 motor; not available as complete.
 ☆ Takes MMS6000 motor; not available as complete.
 * Takes MMS8000 motor; not available as complete.
 † Takes MMS10000 motor; not available as complete.

40S (40 gpm)

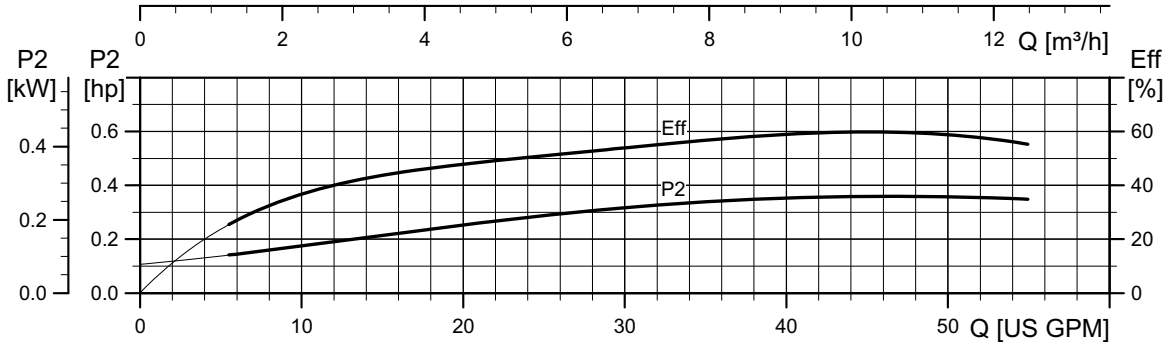
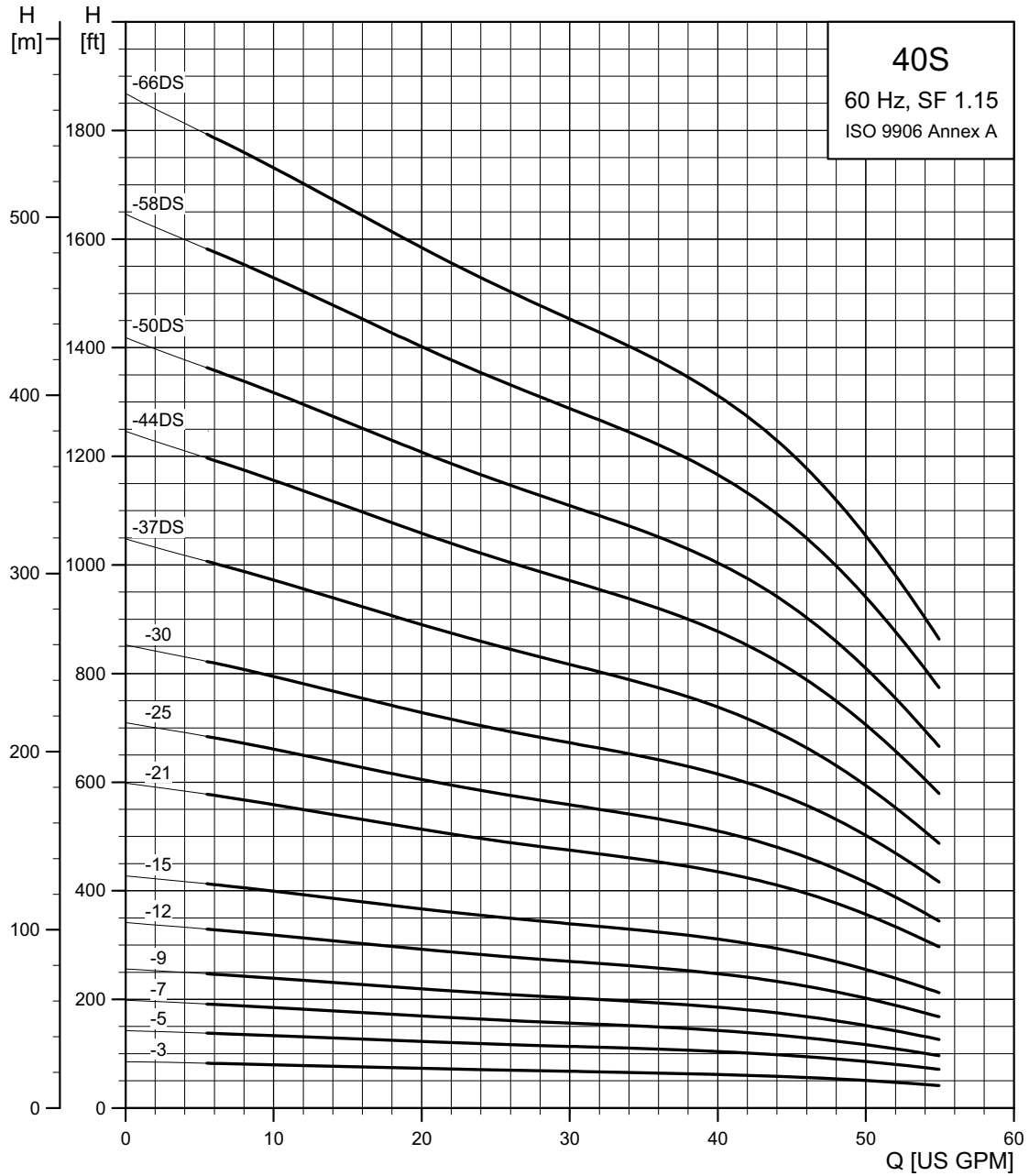

TM05 0233 0 112

40S (40 gpm)

Pump model	Nom. head [ft]	Ph	Volts [V]	Motor [Hp]	Dimensions					Net weight (complete) [lb]	
					A [in (mm)]	B [in (mm)]	C [in (mm)]	D [in (mm)]	E [in (mm)]		
40S - Motor dia. 4 inch, 2 wire motor, 60 Hz, rated flow 40 gpm (2" NPT)											
40S10-3	60	1	230	1	■	25.00 (635)	12.21 (310)	12.80 (325)	3.74 (95)	3.97 (101)	26.1
40S10-5	102	1	230	1.5	■	29.81 (757)	13.71 (348)	16.11 (409)	3.74 (95)	3.97 (101)	30.6
40S - Motor dia. 4 inch, 3 wire motor, 60 Hz, rated flow 40 gpm (2" NPT)											
40S10-3	61	1	230	1	■	25.00 (635)	12.21 (310)	12.8 (325)	3.74 (95)	3.97 (101)	26.1
			230	1.5	■	29.81 (757)	13.71 (348)	16.11 (409)	3.74 (95)	3.97 (101)	30.6
40S15-5	102	3	230	1.5	■	28.31 (719)	12.21 (310)	16.11 (409)	3.74 (95)	3.97 (101)	30.6
			460	1.5	■	28.31 (719)	12.21 (310)	16.11 (409)	3.74 (95)	3.97 (101)	30.6
40S20-7	143	3	230	2	●	38.90 (988)	19.49 (495)	19.41 (493)	3.74 (95)	3.97 (101)	36.9
			230	2	■	33.12 (841)	13.71 (348)	19.41 (493)	3.74 (95)	3.97 (101)	36.9
			460	2	■	33.12 (841)	13.71 (348)	19.41 (493)	3.74 (95)	3.97 (101)	36.9
40S30-9	184	3	230	3	●	45.32 (1151)	22.60 (574)	22.72 (577)	3.74 (95)	3.97 (101)	74.1
			230	3	●	40.71 (1034)	18.00 (457)	22.72 (577)	3.74 (95)	3.97 (101)	81.0
			460	3	●	40.71 (1034)	18.00 (457)	22.72 (577)	3.74 (95)	3.97 (101)	74.7
40S50-12	245	3	230	5	●	54.30 (1379)	26.62 (676)	27.68 (703)	3.74 (95)	3.97 (101)	81.0
			230	5	●	50.40 (1280)	22.72 (577)	27.68 (703)	3.74 (95)	3.97 (101)	74.7
			460	5	●	50.40 (1280)	22.72 (577)	27.68 (703)	3.74 (95)	3.97 (101)	74.7
40S50-15	307	3	230	5	●	59.26 (1505)	26.62 (676)	32.64 (829)	3.74 (95)	3.97 (101)	80.1
			230	5	●	55.36 (1406)	22.72 (577)	32.64 (829)	3.74 (95)	3.97 (101)	80.1
			460	5	●	55.36 (1406)	22.72 (577)	32.64 (829)	3.74 (95)	3.97 (101)	80.1
40S - Motor dia. 6 inch, 3 wire motor, 60 Hz, rated flow 40 gpm (2" NPT)											
40S75-21	429	3	230	7.5	●	69.22 (1758)	26.66 (677)	42.56 (1081)	3.74 (95)	3.97 (101)	113.3
			460	7.5	●	69.22 (1758)	26.66 (677)	42.56 (1081)	3.74 (95)	3.97 (101)	113.3
40S75-25	511	3	230	7.5	●	75.83 (1926)	26.66 (677)	49.18 (1249)	3.74 (95)	3.97 (101)	92.4
			460	7.5	●	75.83 (1926)	26.66 (677)	49.18 (1249)	3.74 (95)	3.97 (101)	92.4
40S100-30	613	3	460	10	●	88.04 (2236)	30.60 (777)	57.45 (1459)	3.74 (95)	3.97 (101)	166.0
40S150-37DS	756	3	230	15	▲	99.34 (2523)	27.88 (708)	71.46 (1815)	5.63 (143)	5.43 (138)	151.9
			460	15	▲	99.34 (2523)	27.88 (708)	71.46 (1815)	5.63 (143)	5.43 (138)	151.9
40S150-44DS	899	3	230	15	▲	110.91 (2817)	27.88 (708)	83.04 (2109)	5.63 (143)	5.43 (138)	165.1
			460	15	▲	110.91 (2817)	27.88 (708)	83.04 (2109)	5.63 (143)	5.43 (138)	151.9
40S200-50DS	1022	3	230	20	▲	136.23 (3460)	30.83 (783)	105.4 (2677)	5.63 (143)	5.51 (140)	226.9
			460	20	▲	136.23 (3460)	30.83 (783)	105.4 (2677)	5.63 (143)	5.51 (140)	226.9
40S200-58DS	1186	3	230	20	▲	149.45 (3796)	30.83 (783)	118.63 (3013)	5.63 (143)	5.51 (140)	251.1
			460	20	▲	149.45 (3796)	30.83 (783)	118.63 (3013)	5.63 (143)	5.51 (140)	251.1
40S200-66DS	1349	3	230	20	▲	162.68 (4132)	30.83 (783)	131.86 (3349)	5.63 (143)	5.51 (140)	266.5
			460	20	▲	162.68 (4132)	30.83 (783)	131.86 (3349)	5.63 (143)	5.51 (140)	266.5

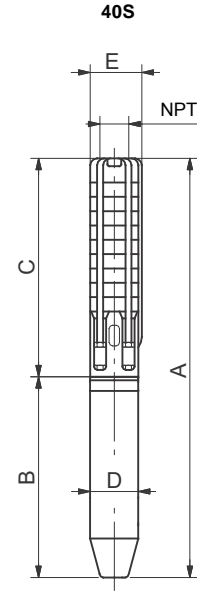

TM05 2399 5011

E = Maximum diameter of pump including cable guard and motor.

Notes:
 Control box is required for 3-wire, single-phase applications. Data does not include control box.
 DS designation = Built into sleeve, 2" NPT, 6" minimum well diameter.
 ■ MS402 motor.
 ● MS4000 motor.
 ▲ MS6 motor.
 △ MMS6000 motor.
 ★ MMS8000 motor.
 ◆ Takes MS6 motor; not available as complete.
 ☆ Takes MMS6000 motor; not available as complete.
 * Takes MMS8000 motor; not available as complete.
 † Takes MMS10000 motor; not available as complete.

60S (60 gpm)

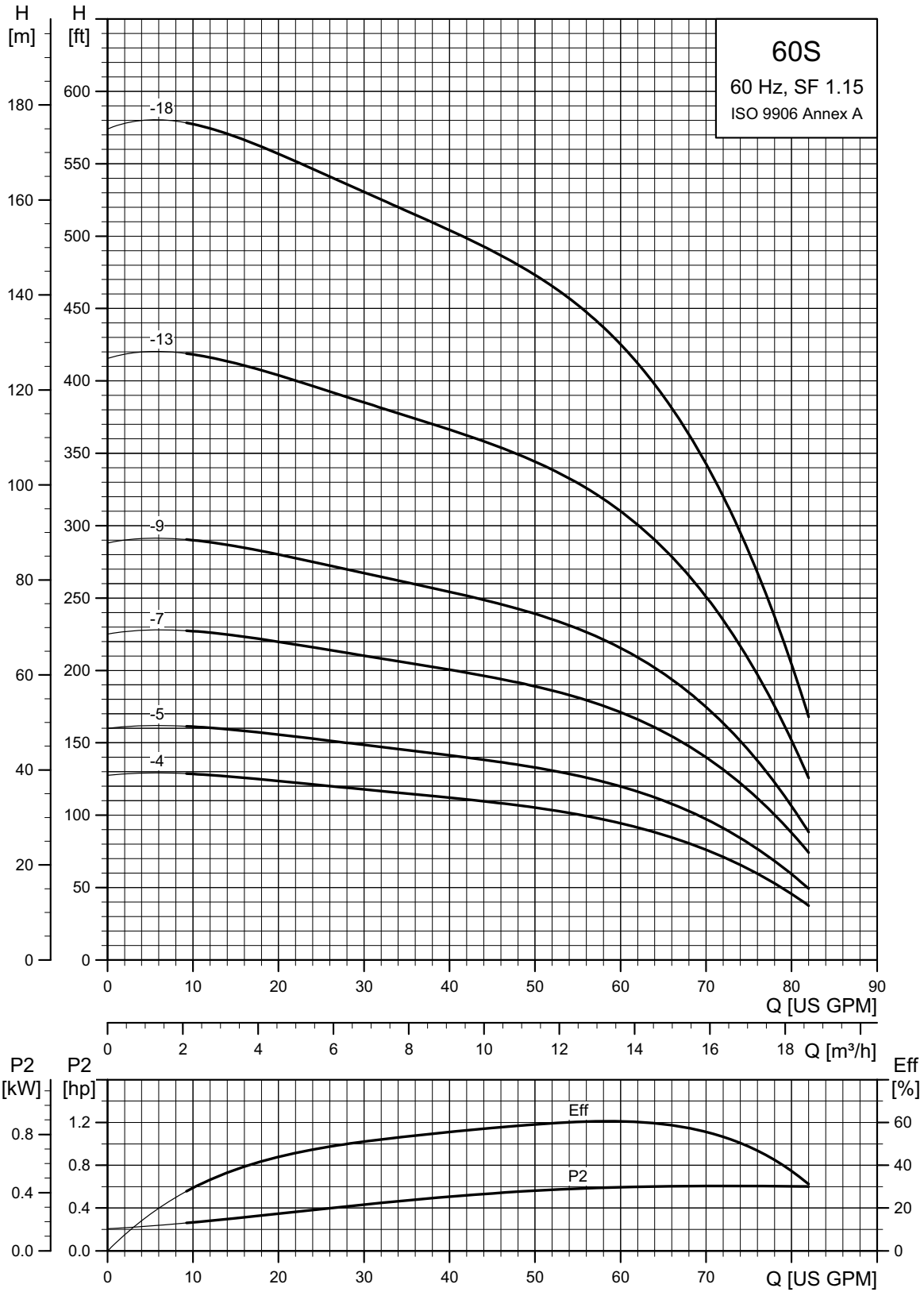

TM05 1736 0112

60S (60 gpm)

Pump model	Nom. head [ft]	Ph	Volts [V]	Motor [Hp]	Dimensions					Net weight (complete) [lb]	
					A [in (mm)]	B [in (mm)]	C [in (mm)]	D [in (mm)]	E [in (mm)]		
60S - Motor dia. 4 inch, 3 wire motor, 60 Hz, rated flow 60 gpm (2" NPT)											
60S20-4	93	1	230	2	●	37.01 (940)	19.49 (495)	17.52 (445)	3.74 (95)	3.97 (101)	36.0
		3	230	2	■	31.23 (793)	13.71 (348)	17.52 (445)	3.74 (95)	3.97 (101)	36.0
		3	460	2	■	31.23 (793)	13.71 (348)	17.52 (445)	3.74 (95)	3.97 (101)	36.0
60S30-5	117	1	230	3	●	42.68 (1084)	22.60 (574)	20.08 (510)	3.74 (95)	3.97 (101)	61.2
		3	230	3	●	38.08 (967)	18.00 (457)	20.08 (510)	3.74 (95)	3.97 (101)	49.5
		3	460	3	●	38.08 (967)	18.00 (457)	20.08 (510)	3.74 (95)	3.97 (101)	58.5
60S50-7	164	1	230	5	●	51.82 (1316)	26.62 (676)	25.20 (640)	3.74 (95)	3.97 (101)	81.0
		3	230	5	●	47.92 (1217)	22.72 (577)	25.20 (640)	3.74 (95)	3.97 (101)	49.5
		3	460	5	●	47.92 (1217)	22.72 (577)	25.20 (640)	3.74 (95)	3.97 (101)	72.0
60S50-9	210	1	230	5	●	56.93 (1446)	26.62 (676)	30.32 (770)	3.74 (95)	3.97 (101)	85.5
		3	230	5	●	53.04 (1347)	22.72 (577)	30.32 (770)	3.74 (95)	3.97 (101)	76.5
		3	460	5	●	53.04 (1347)	22.72 (577)	30.32 (770)	3.74 (95)	3.97 (101)	76.5
60S75-13	304	3	230	7.5	●	67.21 (1707)	26.66 (677)	40.56 (1030)	3.74 (95)	3.97 (101)	83.3
		3	460	7.5	●	67.21 (1707)	26.66 (677)	40.56 (1030)	3.74 (95)	3.97 (101)	136.8
60S100-18	420	3	460	10	●	83.94 (2132)	30.60 (777)	53.35 (1355)	3.74 (95)	3.97 (101)	175.5
60S - Motor dia. 6 inch, 3 wire motor, 60 Hz, rated flow 60 gpm (2" NPT)											
60S75-13	304	3	230	7.5	▲	65.24 (1657)	22.25 (565)	43.00 (1092)	5.63 (143)	5.43 (138)	136.8
		3	460	7.5	▲	65.24 (1657)	22.25 (565)	43.00 (1092)	5.63 (143)	5.43 (138)	136.8
60S100-18	420	3	230	10	▲	79.02 (2007)	23.23 (590)	55.79 (1417)	5.63 (143)	5.43 (138)	207.0
		3	460	10	▲	79.02 (2007)	23.23 (590)	55.79 (1417)	5.63 (143)	5.43 (138)	207.0

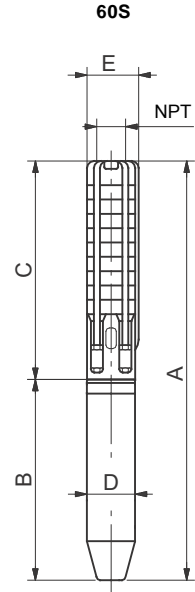

TM05 2399 5011

E = Maximum diameter of pump including cable guard and motor.

Notes:

Control box is required for 3-wire, single-phase applications. Data does not include control box diameter.

- MS402 motor.
- MS4000 motor.
- ▲ MS6 motor.
- △ MMS6000 motor.
- ★ MMS8000 motor.
- ◆ Takes MS6 motor; not available as complete.
- ⊙ Takes MMS6000 motor; not available as complete.
- * Takes MMS8000 motor; not available as complete.
- † Takes MMS10000 motor; not available as complete.

75S (75 gpm)

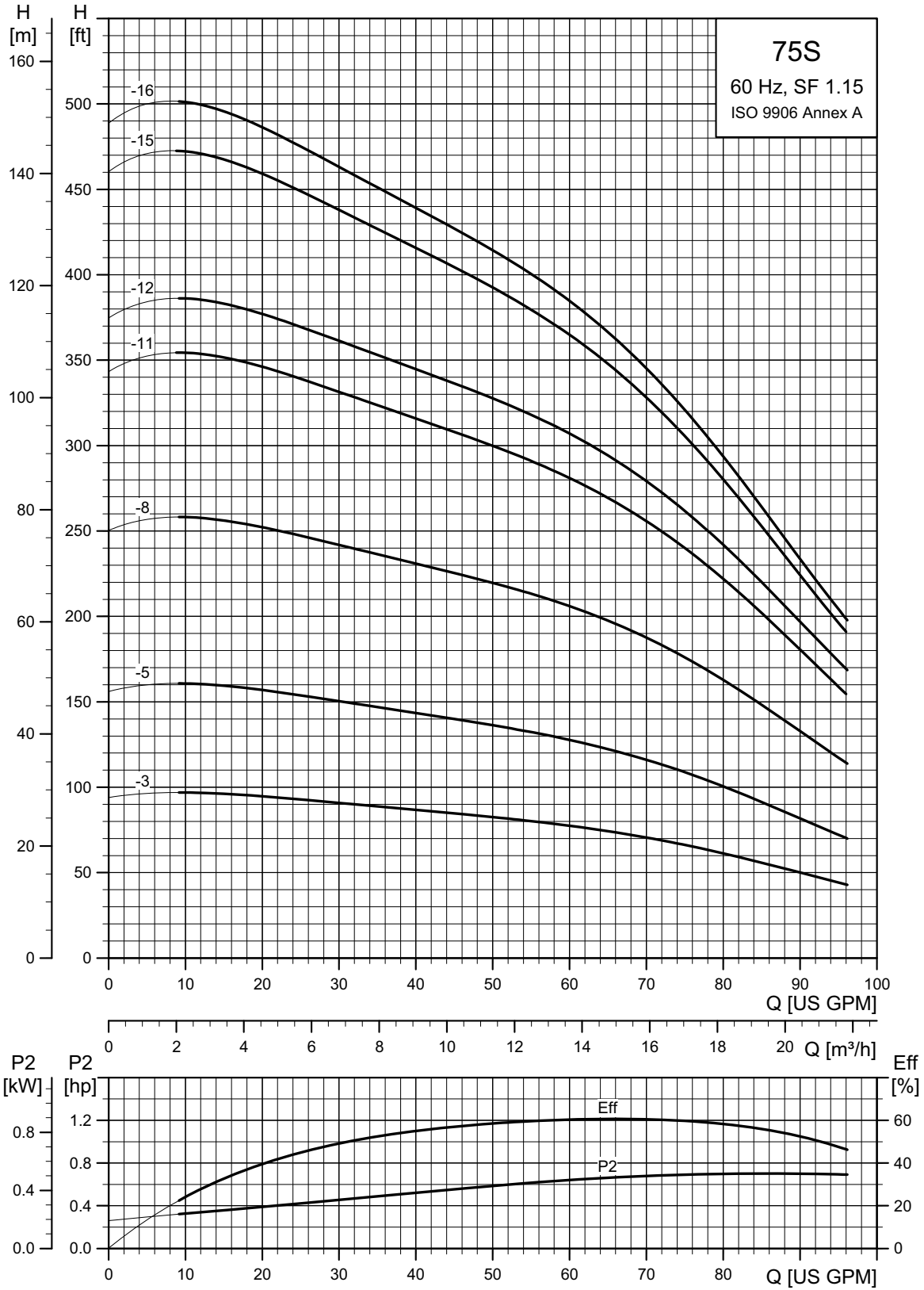

TM05 0234 0112

75S (75 gpm)

Pump model	Nom. head [ft]	Ph	Volts [V]	Motor [Hp]	Dimensions					Net weight (complete) [lb]	
					A [in (mm)]	B [in (mm)]	C [in (mm)]	D [in (mm)]	E [in (mm)]		
75S - Motor dia. 4 inch, 3 wire motor, 60 Hz, rated flow 75 gpm (2" NPT)											
75S20-3	68	1	230	2	●	34.45 (875)	19.49 (495)	14.97 (380)	3.74 (95)	3.97 (101)	36.9
		3	230	2	■	28.67 (728)	13.71 (348)	14.97 (380)	3.74 (95)	3.97 (101)	34.2
		3	460	2	■	28.67 (728)	13.71 (348)	14.97 (380)	3.74 (95)	3.97 (101)	34.2
75S30-5	114	1	230	3	●	42.68 (1084)	22.60 (574)	20.08 (510)	3.74 (95)	3.97 (101)	69.3
		3	230	3	●	38.08 (967)	18.00 (457)	20.08 (510)	3.74 (95)	3.97 (101)	57.6
		3	460	3	●	38.08 (967)	18.00 (457)	20.08 (510)	3.74 (95)	3.97 (101)	57.6
75S50-8	182	1	230	5	●	54.38 (1381)	26.62 (676)	27.76 (705)	3.74 (95)	3.97 (101)	87.3
		3	230	5	●	50.48 (1282)	22.72 (577)	27.76 (705)	3.74 (95)	3.97 (101)	74.7
		3	460	5	●	50.48 (1282)	22.72 (577)	27.76 (705)	3.74 (95)	3.97 (101)	74.7
75S75-12	273	3	230	7.5	●	64.65 (1642)	26.66 (677)	38.00 (965)	3.74 (95)	3.97 (101)	81.4
		3	460	7.5	●	64.65 (1642)	26.66 (677)	38.00 (965)	3.74 (95)	3.97 (101)	81.4
75S100-16	364	3	460	10	●	78.82 (2002)	30.60 (777)	48.23 (1225)	3.74 (95)	3.97 (101)	138.0
75S - Motor dia. 6 inch, 3 wire motor, 60 Hz, rated flow 75 gpm (2" NPT)											
75S75-11	250	3	230	7.5	▲	60.12 (1527)	22.25 (565)	37.88 (962)	5.63 (143)	5.43 (138)	130.5
		3	460	7.5	▲	60.12 (1527)	22.25 (565)	37.88 (962)	5.63 (143)	5.43 (138)	130.5
75S100-15	341	3	230	10	▲	70.16 (1782)	23.23 (590)	46.93 (1192)	5.63 (143)	5.43 (138)	175.5
		3	460	10	▲	70.16 (1782)	23.23 (590)	46.93 (1192)	5.63 (143)	5.43 (138)	175.5

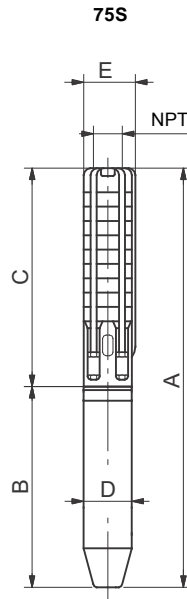

TM05 2399 5011

E = Maximum diameter of pump including cable guard and motor.

Notes:

Control box is required for 3-wire, single-phase applications. Data does not include control box.

- MS402 motor.
- MS4000 motor.
- ▲ MS6 motor.
- △ MMS6000 motor.
- ★ MMS8000 motor.
- ◆ Takes MS6 motor; not available as complete.
- ☆ Takes MMS6000 motor; not available as complete.
- * Takes MMS8000 motor; not available as complete.
- † Takes MMS10000 motor; not available as complete.

85S (85 gpm)

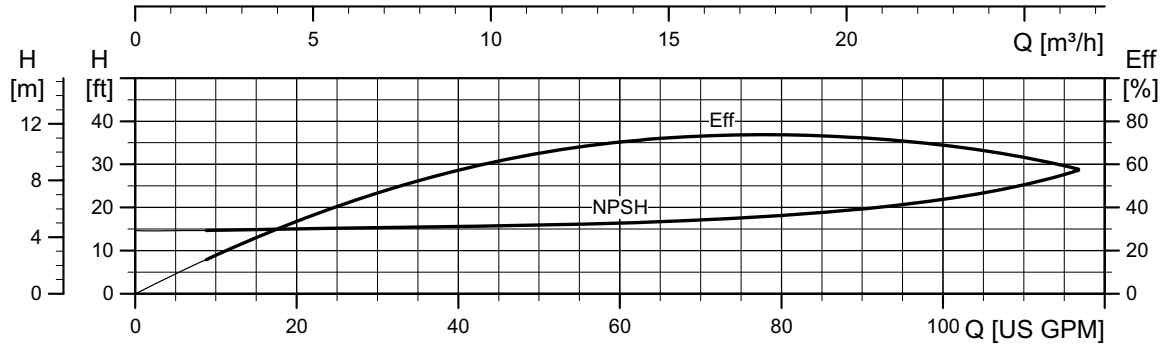
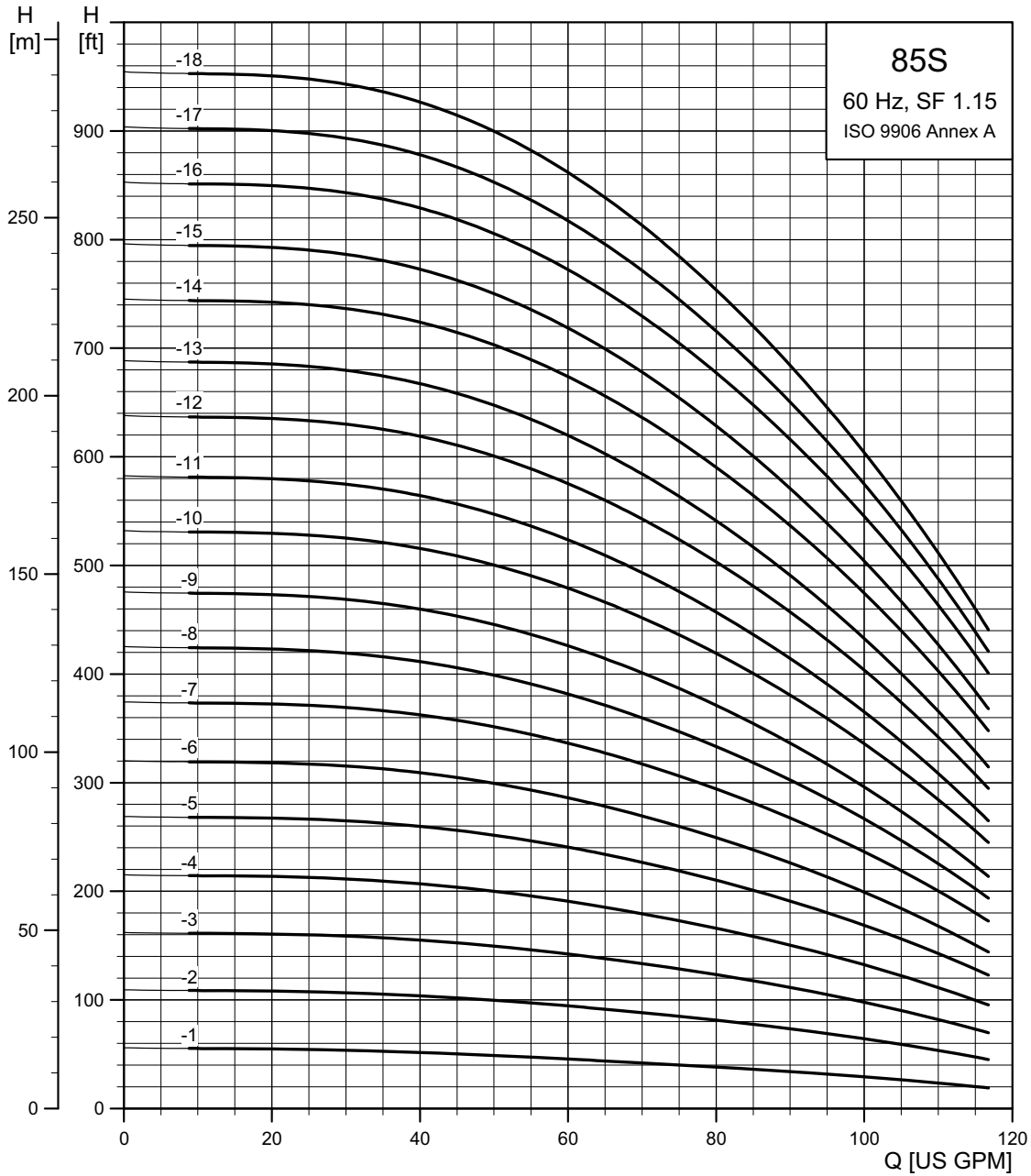

TM05 0235 0112

85S (85 gpm)

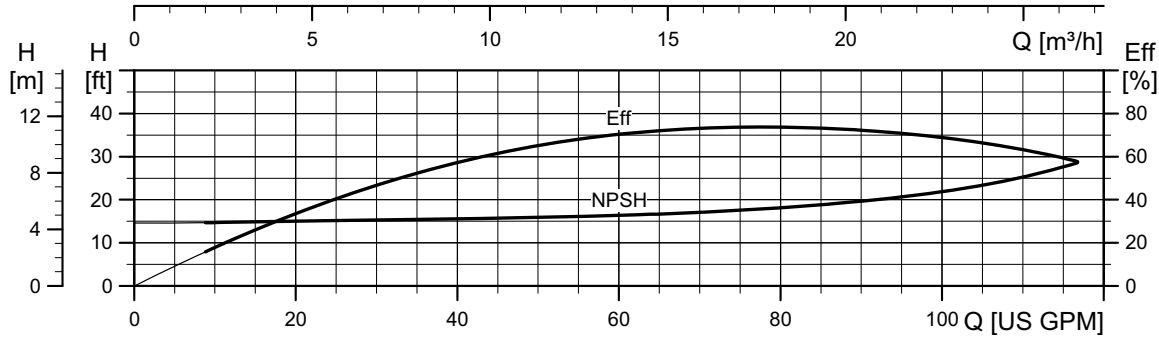
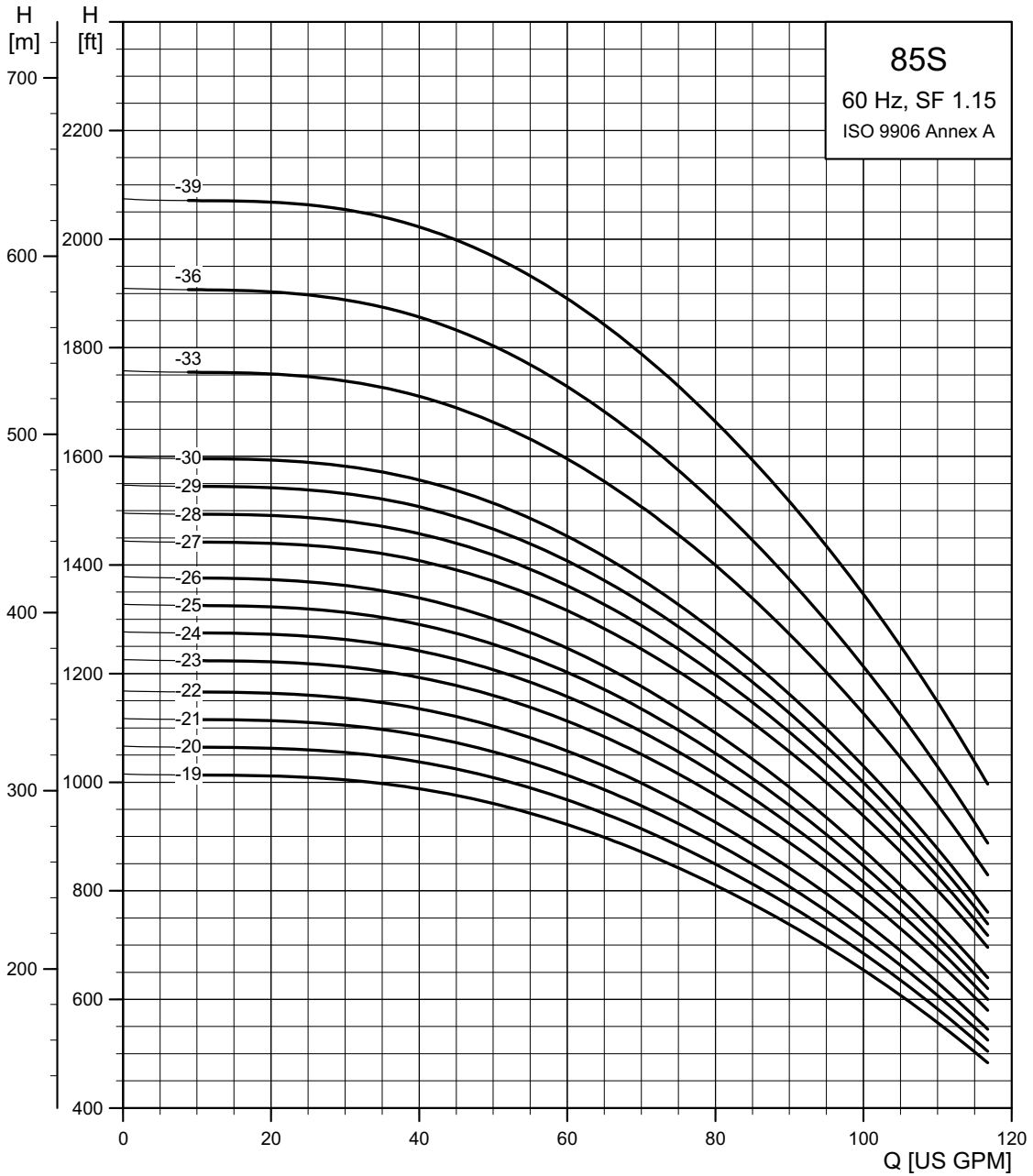

TMM05 0236 0112

85S (85 gpm) pump power requirement (P2)

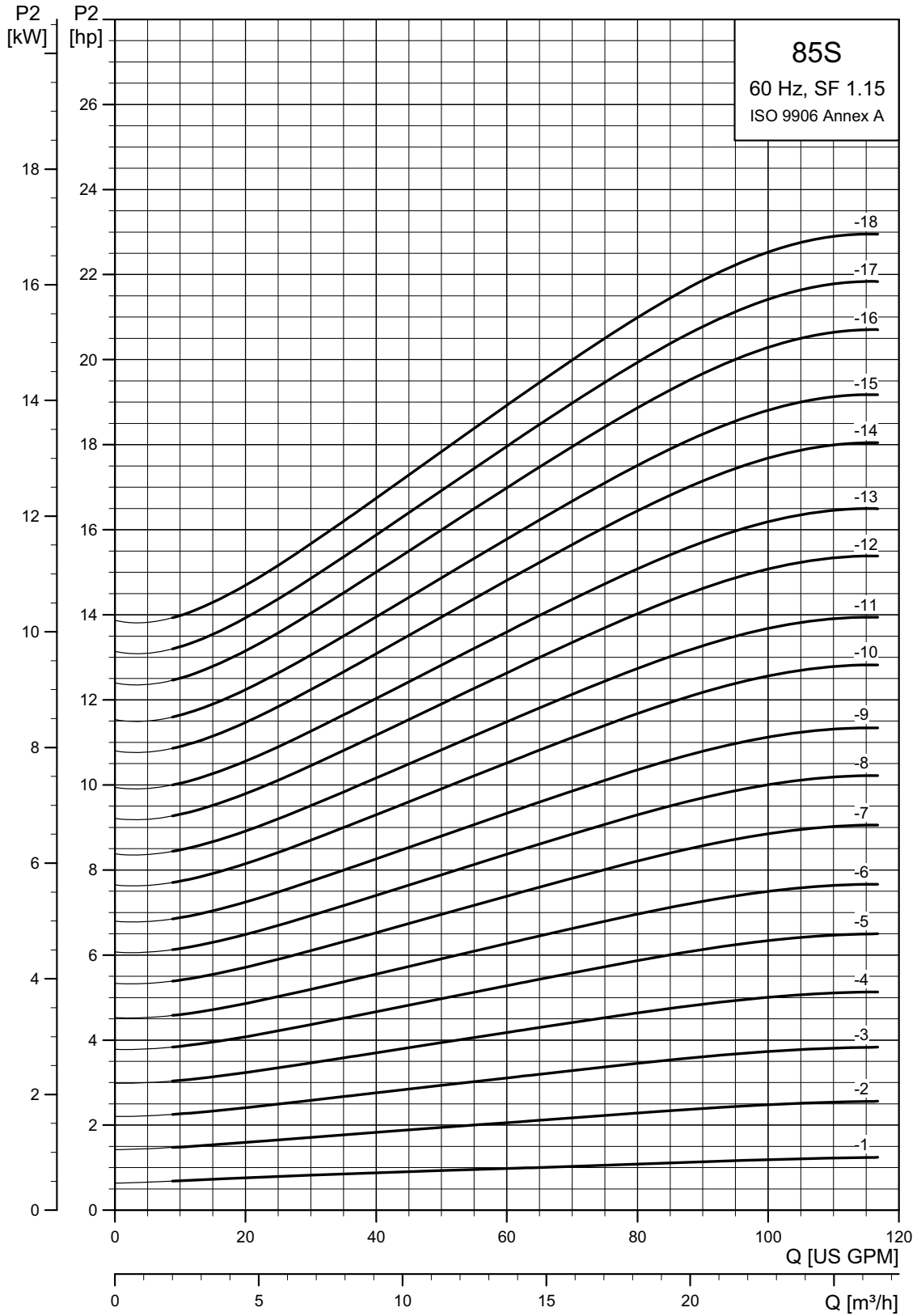

TM05 0237 0112

85S (85 gpm) pump power requirement (P2)

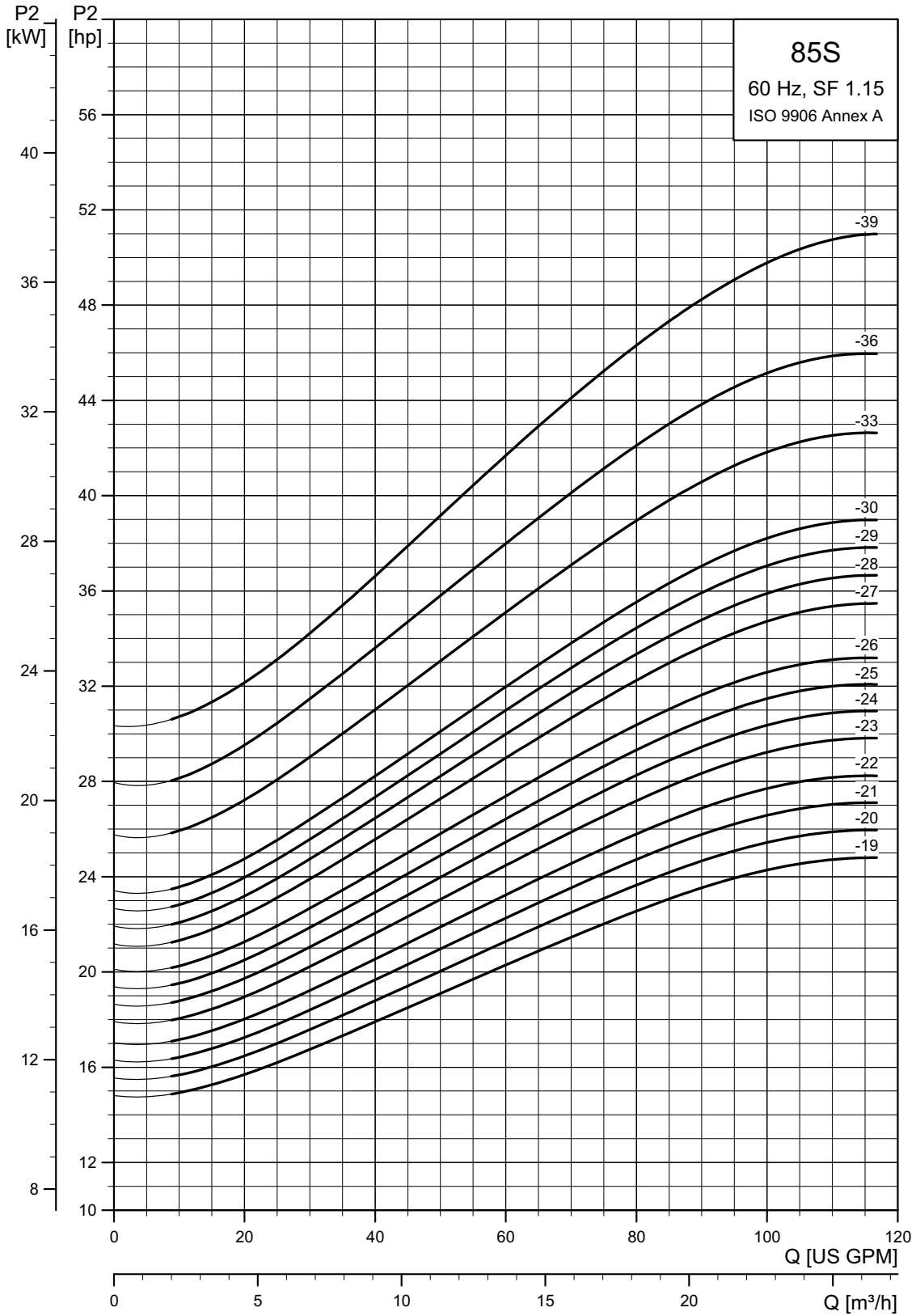

TM05 0238 0112

85S (85 gpm)

Pump model	Nom. head [ft]	Ph	Volts [V]	Motor [Hp]	Dimensions					Net weight (complete) [lb]	
					A [in (mm)]	B [in (mm)]	C [in (mm)]	D [in (mm)]	E [in (mm)]		
85S - Motor dia. 4 inch, 3 wire motor, 60 Hz, rated flow 85 gpm (3" NPT)											
85S15-1	35	1	230	1.5	■	27.60 (701)	15.24 (387)	12.36 (314)	3.74 (95)	5.16 (131)	29.7
		3	230	1.5	■	26.02 (661)	13.66 (347)	12.36 (314)	3.74 (95)	5.16 (131)	29.7
		3	460	1.5	■	26.02 (661)	13.66 (347)	12.36 (314)	3.74 (95)	5.16 (131)	29.7
85S30-2	74	1	230	3	●	32.69 (951)	22.72 (577)	14.72 (374)	3.74 (95)	5.16 (131)	55.8
		3	230	3	●	32.69 (830)	17.96 (456)	14.72 (374)	3.74 (95)	5.16 (131)	47.7
		3	460	3	●	32.69 (830)	17.96 (456)	14.72 (374)	3.74 (95)	5.16 (131)	47.7
85S50-3	114	1	230	5	●	43.78 (1112)	26.65 (677)	17.13 (435)	3.74 (95)	5.16 (131)	67.5
		3	230	5	●	39.80 (1011)	22.69 (576)	17.13 (435)	3.74 (95)	5.16 (131)	51.3
		3	460	5	●	39.80 (1011)	22.69 (576)	17.13 (435)	3.74 (95)	5.16 (131)	51.3
85S50-4	154	1	230	5	●	43.78 (1112)	26.65 (677)	17.13 (435)	3.74 (95)	5.16 (131)	69.3
		3	230	5	●	39.80 (1011)	22.69 (576)	17.13 (435)	3.74 (95)	5.16 (131)	61.2
		3	460	5	●	39.80 (1011)	22.69 (576)	17.13 (435)	3.74 (95)	5.16 (131)	61.2
85S75-5	194	3	230	7.5	●	48.50 (1232)	26.62 (676)	21.89 (556)	3.74 (95)	5.16 (131)	73.8
		3	460	7.5	●	48.50 (1232)	26.62 (676)	21.89 (556)	3.74 (95)	5.16 (131)	73.8
85S75-6	234	3	230	7.5	●	50.87 (1292)	26.62 (676)	24.25 (616)	3.74 (95)	5.16 (131)	85.5
		3	460	7.5	●	50.87 (1292)	26.62 (676)	24.25 (616)	3.74 (95)	5.16 (131)	76.5
85S100-7	274	3	460	10	●	57.21 (1453)	30.56 (776)	26.65 (677)	3.74 (95)	5.16 (131)	136.8
85S100-8	314	3	460	10	●	59.57 (1513)	30.56 (776)	29.02 (737)	3.74 (95)	5.16 (131)	138.6
85S100-9	353	3	460	10	●	61.98 (1574)	30.56 (776)	31.42 (798)	3.74 (95)	5.16 (131)	140.4

85S - Motor dia. 6 inch, 3 wire motor, 60 Hz, rated flow 85 gpm (3" NPT)											
85S75-5	194	3	230	7.5	▲	44.76 (1137)	22.52 (565)	22.52 (572)	5.63 (143)	5.59 (142)	98.1
		3	460	7.5	▲	44.76 (1137)	22.52 (565)	22.52 (572)	5.63 (143)	5.59 (142)	98.1
85S75-6	234	3	230	7.5	▲	47.12 (1197)	22.24 (565)	24.88 (632)	5.63 (143)	5.59 (142)	99.9
		3	460	7.5	▲	47.12 (1197)	22.24 (565)	24.88 (632)	5.63 (143)	5.59 (142)	99.9
85S100-7	274	3	230	10	▲	50.51 (1283)	23.23 (590)	27.28 (693)	5.63 (143)	5.59 (142)	103.5
		3	460	10	▲	50.51 (1283)	23.23 (590)	27.28 (693)	5.63 (143)	5.59 (142)	103.5
85S100-8	314	3	230	10	▲	52.87 (1343)	23.23 (590)	29.65 (753)	5.63 (143)	5.59 (142)	105.3
		3	460	10	▲	52.87 (1343)	23.23 (590)	29.65 (753)	5.63 (143)	5.59 (142)	105.3
85S100-9	353	3	230	10	▲	55.28 (1404)	23.23 (590)	32.05 (814)	5.63 (143)	5.60 (142)	108.0
		3	460	10	▲	55.28 (1404)	23.23 (590)	32.05 (814)	5.63 (143)	5.60 (142)	108.0
85S150-10	393	3	230	15	▲	62.29 (1582)	27.88 (708)	34.41 (874)	5.63 (143)	5.60 (142)	122.4
		3	460	15	▲	62.29 (1582)	27.88 (708)	34.41 (874)	5.63 (143)	5.60 (142)	122.4
85S150-11	433	3	230	15	▲	64.69 (1643)	27.88 (708)	36.82 (935)	5.63 (143)	5.60 (142)	126.0
		3	460	15	▲	64.69 (1643)	27.88 (708)	36.82 (935)	5.63 (143)	5.60 (142)	126.0
85S150-12	473	3	230	15	▲	67.05 (1703)	27.88 (708)	39.18 (995)	5.63 (143)	5.60 (142)	133.2
		3	460	15	▲	67.05 (1703)	27.88 (708)	39.18 (995)	5.63 (143)	5.60 (142)	133.2
85S150-13	513	3	230	15	▲	69.45 (1764)	27.88 (708)	41.58 (1056)	5.63 (143)	5.60 (142)	135.0
		3	460	15	▲	69.45 (1764)	27.88 (708)	41.58 (1056)	5.63 (143)	5.60 (142)	135.0

Notes:

Control box is required for 3-wire, single-phase applications. Data does not include control box.

- MS402 motor.
- MS4000 motor.
- ▲ MS6 motor.
- △ MMS6000 motor.
- ★ MMS8000 motor.
- ◆ Takes MS6 motor; not available as complete.
- ☆ Takes MMS6000 motor; not available as complete.
- * Takes MMS8000 motor; not available as complete.
- † Takes MMS10000 motor; not available as complete.

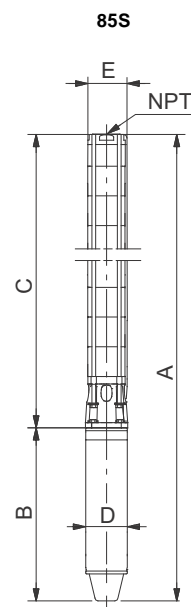

TM05 2400 5011

E = Maximum diameter of pump including cable guard and motor.

85S (85 gpm)

Pump model	Nom. head [ft]	Ph	Volts [V]	Motor [Hp]	Dimensions					Net weight (complete) [lb]	
					A [in (mm)]	B [in (mm)]	C [in (mm)]	D [in (mm)]	E [in (mm)]		
85S - Motor dia. 6 inch, 3 wire motor, 60 Hz, rated flow 85 gpm (3" NPT)											
85S200-14	533	3	230	20	▲	74.77 (1899)	30.83 (783)	43.94 (1116)	5.63 (143)	5.60 (142)	143.1
		3	460	20	▲	74.77 (1899)	30.83 (783)	43.94 (1116)	5.63 (143)	5.60 (142)	143.1
85S200-15	593	3	230	20	▲	77.17 (1960)	30.83 (783)	46.34 (1177)	5.63 (143)	5.60 (142)	147.6
		3	460	20	▲	77.17 (1960)	30.83 (783)	46.34 (1177)	5.63 (143)	5.60 (142)	147.6
85S200-16	633	3	230	20	▲	79.53 (2020)	30.83 (783)	48.71 (1237)	5.63 (143)	5.60 (142)	157.5
		3	460	20	▲	79.53 (2020)	30.83 (783)	48.71 (1237)	5.63 (143)	5.60 (142)	157.5
85S200-17	672	3	230	20	▲	81.93 (2081)	30.83 (783)	51.11 (1298)	5.63 (143)	5.60 (142)	160.2
		3	460	20	▲	81.93 (2081)	30.83 (783)	51.11 (1298)	5.63 (143)	5.60 (142)	160.2
85S200-18	712	3	230	20	▲	84.30 (2141)	30.83 (783)	53.47 (1358)	5.63 (143)	5.60 (142)	161.1
		3	460	20	▲	84.30 (2141)	30.83 (783)	53.47 (1358)	5.63 (143)	5.60 (142)	179.0
85S250-19	752	3	230	25	▲	88.86 (2257)	33.00 (838)	55.87 (1419)	5.63 (143)	5.60 (142)	191.7
		3	460	25	▲	88.86 (2257)	33.00 (838)	55.87 (1419)	5.63 (143)	5.60 (142)	191.7
85S250-20	792	3	230	25	▲	91.86 (2333)	33.00 (838)	58.86 (1495)	5.63 (143)	5.60 (142)	195.3
		3	460	25	▲	91.86 (2333)	33.00 (838)	58.86 (1495)	5.63 (143)	5.60 (142)	195.3
85S250-21	832	3	230	25	▲	94.26 (2394)	33.00 (838)	61.26 (1556)	5.63 (143)	5.60 (142)	198.0
		3	460	25	▲	94.26 (2394)	33.00 (838)	61.26 (1556)	5.63 (143)	5.60 (142)	198.0
85S250-22	872	3	230	25	▲	96.62 (2454)	33.00 (838)	63.63 (1616)	5.63 (143)	5.60 (142)	199.8
		3	460	25	▲	96.62 (2454)	33.00 (838)	63.63 (1616)	5.63 (143)	5.60 (142)	199.8
85S300-23	912	3	230	30	▲	101.54 (2579)	35.56 (903)	65.99 (1676)	5.63 (143)	5.60 (142)	199.8
		3	460	30	▲	101.54 (2579)	35.56 (903)	65.99 (1676)	5.63 (143)	5.60 (142)	199.8
85S300-24	952	3	230	30	▲	103.94 (2640)	35.56 (903)	68.39 (1737)	5.63 (143)	5.60 (142)	216.0
		3	460	30	▲	103.94 (2640)	35.56 (903)	68.39 (1737)	5.63 (143)	5.60 (142)	216.0
85S300-25	991	3	230	30	▲	106.34 (2701)	35.56 (903)	70.79 (1798)	5.63 (143)	5.60 (142)	219.6
		3	460	30	▲	106.34 (2701)	35.56 (903)	70.79 (1798)	5.63 (143)	5.60 (142)	219.6
85S300-26	1031	3	230	30	▲	108.71 (2761)	35.56 (903)	73.15 (1858)	5.63 (143)	5.60 (142)	221.4
		3	460	30	▲	108.71 (2761)	35.56 (903)	73.15 (1858)	5.63 (143)	5.60 (142)	221.4
85S300-27	1071	3	230	30	▲	111.11 (2822)	35.56 (903)	75.56 (1919)	5.63 (143)	5.60 (142)	234.9
		3	460	30	▲	111.11 (2822)	35.56 (903)	75.56 (1919)	5.63 (143)	5.60 (142)	234.9
85S400-28	1111	3	460	40	▲	118.19 (3002)	40.28 (1023)	77.92 (1979)	5.63 (143)	5.60 (142)	246.6
85S400-29	1151	3	460	40	▲	120.6 (3063)	40.28 (1023)	80.32 (2040)	5.63 (143)	5.60 (142)	248.4
85S400-30	1191	3	460	40	▲	122.96 (3123)	40.28 (1023)	82.68 (2100)	5.63 (143)	5.60 (142)	270.0
85S400-33DS	1310	3	460	40	▲	139.22 (3536)	40.28 (1023)	98.94 (2513)	5.63 (143)	6.90 (176)	515.5
85S400-36DS	1430	3	460	40	▲	146.34 (3717)	40.28 (1023)	106.07 (2694)	5.63 (143)	6.90 (176)	454.8
85S500-39DS	1510	3	460	50	▲	169.26 (4299)	56.03 (1423)	113.23 (2876)	5.63 (143)	6.90 (176)	469.0
85S - Motor dia. 8 inch, 3 wire motor, 60 Hz, rated flow 85 gpm (3" NPT)											
85S400-33DS	1310	3	460	40	★	140.87 (3578)	43.71 (1110)	97.17 (2468)	7.56 (192)	7.56 (192)	652.7
85S400-36DS	1310	3	460	40	★	147.96 (3758)	43.71 (1110)	104.26 (2648)	7.56 (192)	7.56 (192)	592.0
85S400-39DS	1510	3	460	50	★	155.04 (3938)	43.71 (1110)	111.34 (2828)	7.56 (192)	7.56 (192)	537.2

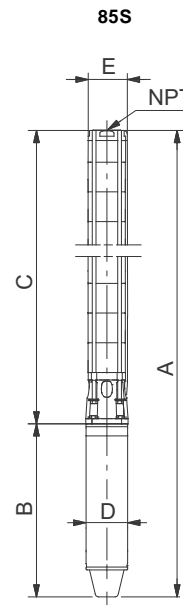

TM05 2400 5011

E = Maximum diameter of pump including cable guard and motor.

Notes:

Control box is required for 3-wire, single-phase applications. Data does not include control box.

DS designation = Built into sleeve, 3" NPT, 8" minimum well diameter.

- MS402 motor.
- MS4000 motor.
- ▲ MS6 motor.
- △ MMS6000 motor.
- ★ MMS8000 motor.
- ◆ Takes MS6 motor; not available as complete.
- ☆ Takes MMS6000 motor; not available as complete.
- * Takes MMS8000 motor; not available as complete.
- † Takes MMS10000 motor; not available as complete.

150S (150 gpm)

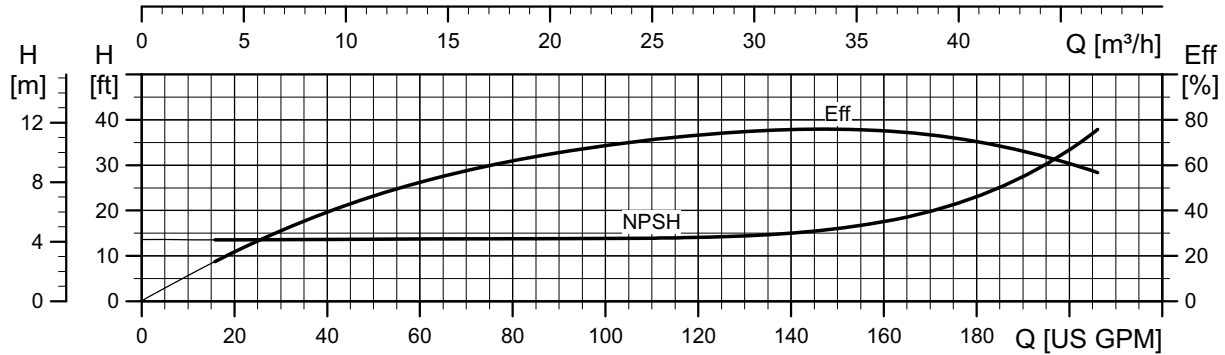
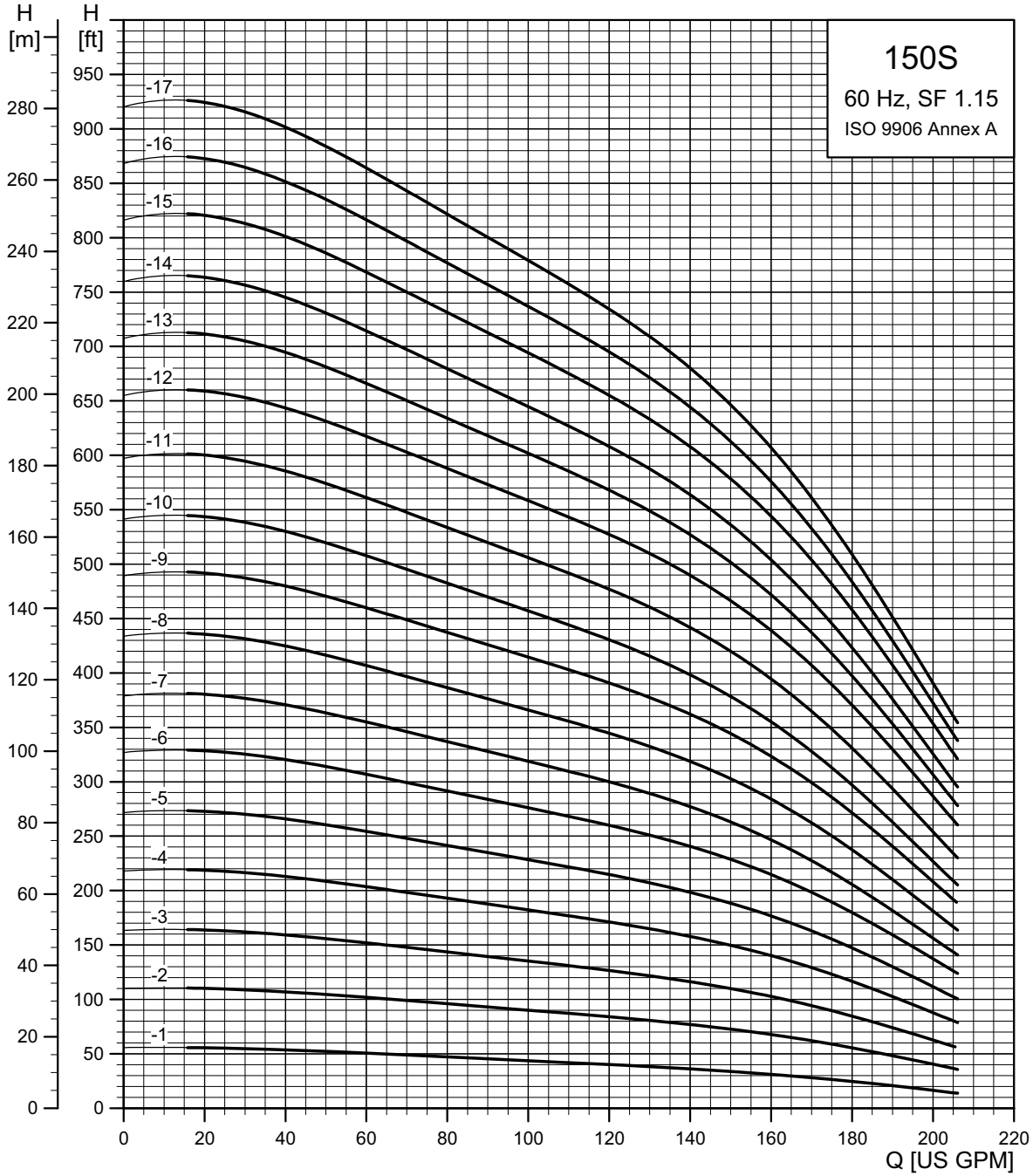

TM05 0239 0112

150S (150 gpm)

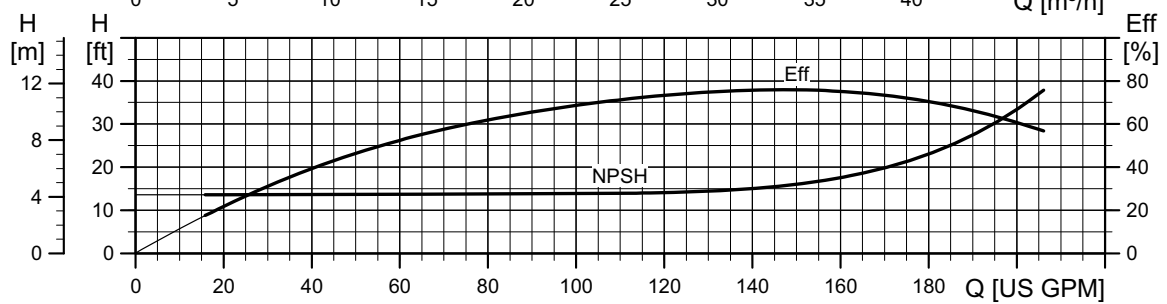
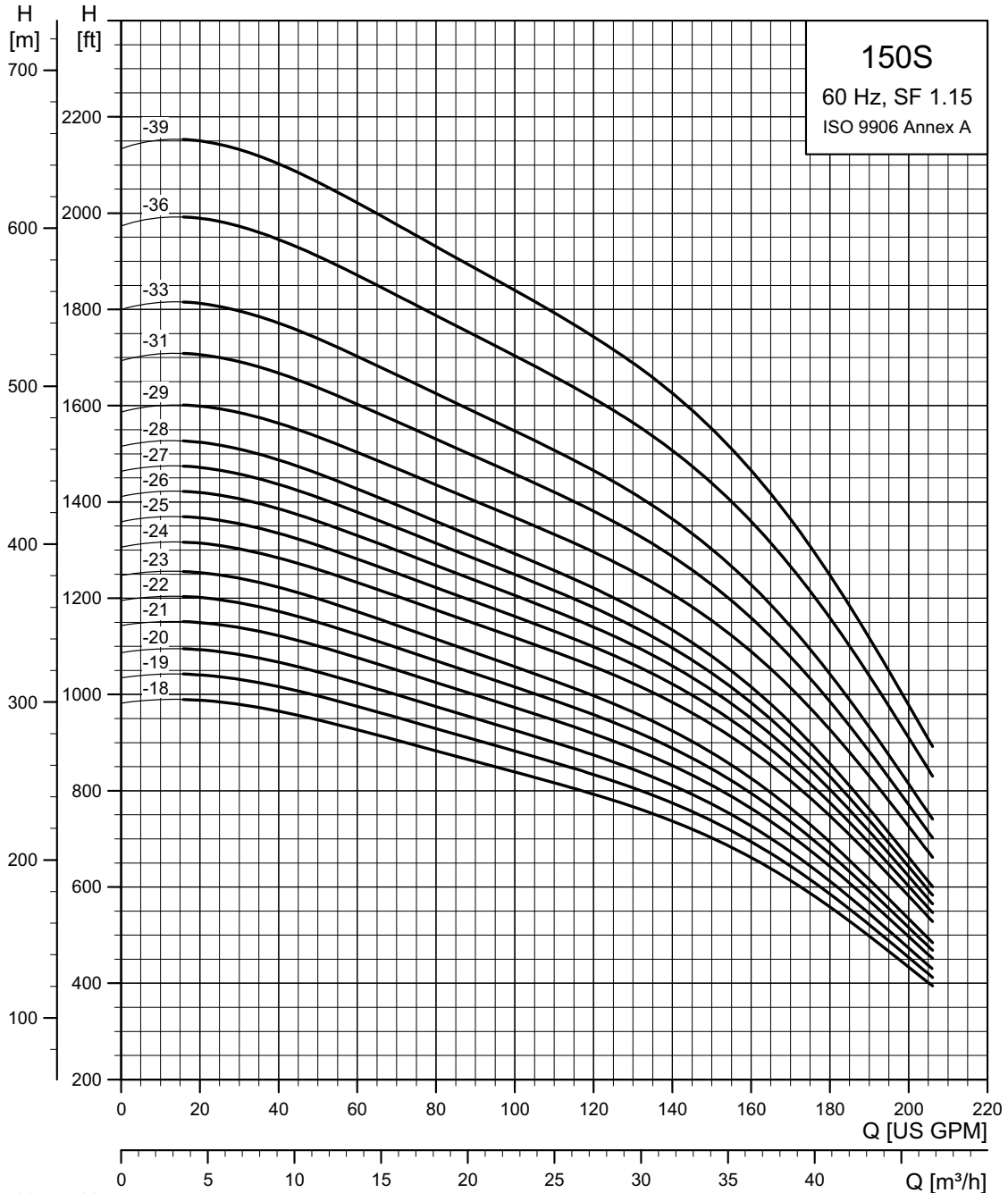

TM05 0240 0112

150S (150 gpm) pump power requirement (P2)

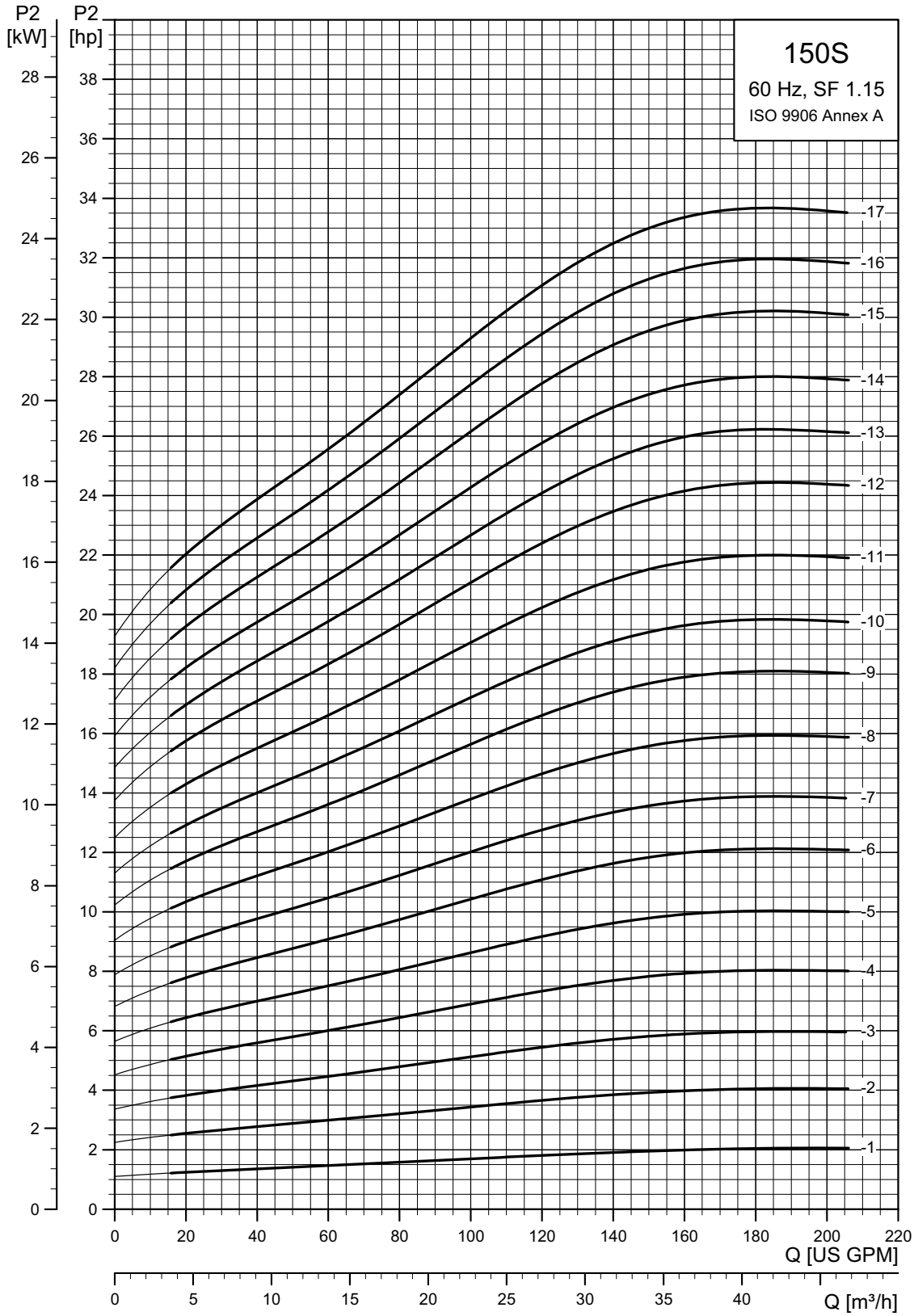

TM05 0241 0112

150S (150 gpm) pump power requirement (P2)

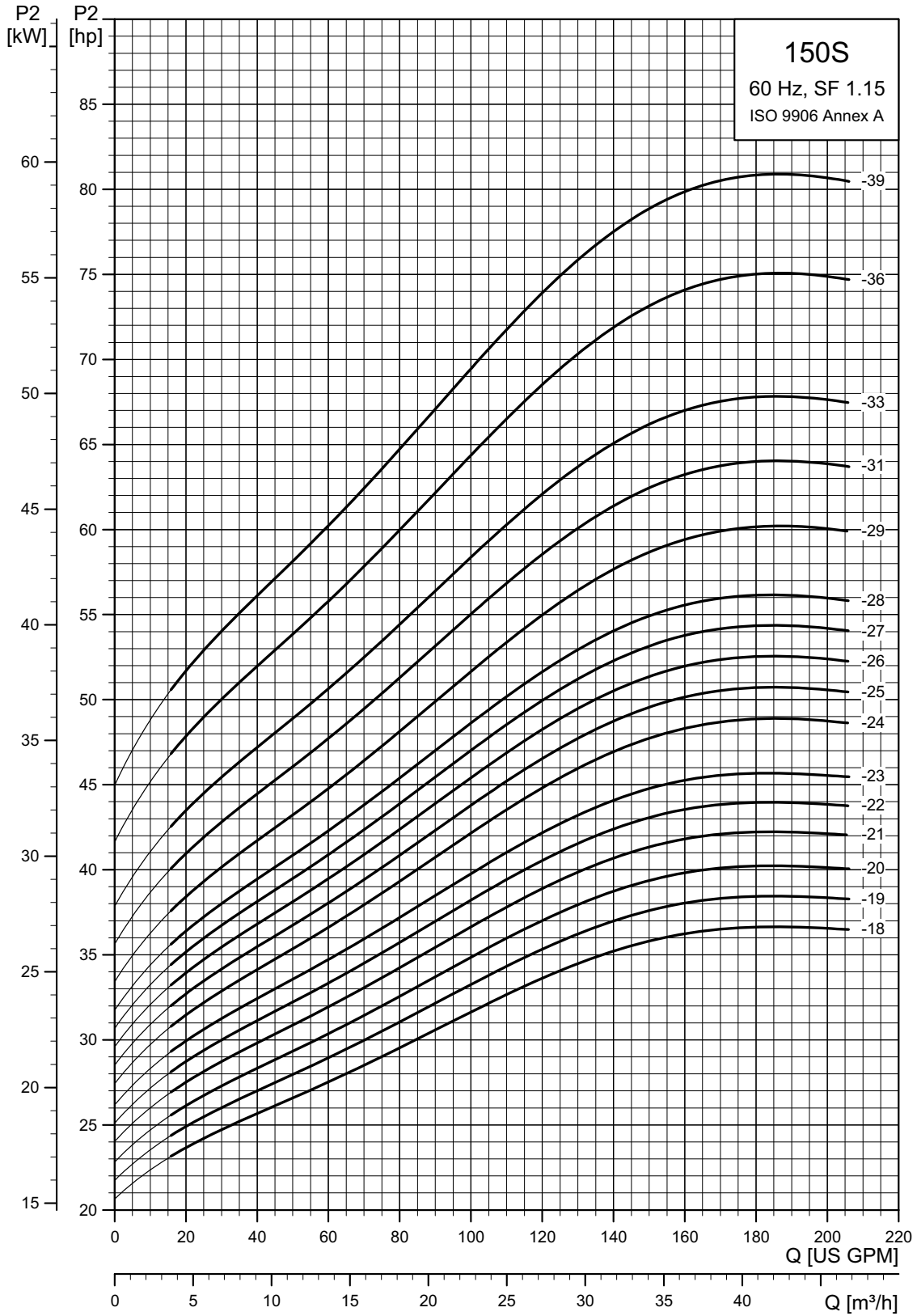

TM05 0242 0112

150S (150 gpm)

Pump model	Nom. head [ft]	Ph	Volts [V]	Motor [Hp]	Dimensions					Net weight (complete) [lb]	
					A [in (mm)]	B [in (mm)]	C [in (mm)]	D [in (mm)]	E [in (mm)]		
150S - Motor dia. 4 inch, 3 wire motor, 60 Hz, rated flow 150 gpm (3" NPT)											
150S20-1	33	1	230	2	●	33.30 (846)	19.57 (497)	13.75 (349)	3.75 (95)	5.16 (131)	49.5
		3	230	2	■	28.98 (736)	15.23 (387)	13.75 (349)	3.75 (95)	5.16 (131)	45.0
		3	460	2	■	28.98 (736)	15.23 (387)	13.75 (349)	3.75 (95)	5.16 (131)	45.0
150S50-2	71	1	230	5	●	44.17 (1122)	26.65 (677)	17.52 (445)	3.75 (95)	5.16 (131)	67.5
		3	230	5	●	40.20 (1021)	22.69 (576)	17.52 (445)	3.75 (95)	5.16 (131)	42.3
		3	460	5	●	40.20 (1021)	22.69 (576)	17.52 (445)	3.75 (95)	5.16 (131)	42.3
150S75-3	108	3	230	7.5	●	47.91 (1217)	26.63 (676)	21.3 (541)	3.75 (95)	5.16 (131)	51.3
		3	460	7.5	●	47.91 (1217)	26.63 (676)	21.3 (541)	3.75 (95)	5.16 (131)	82.8
150S75-4	146	3	230	7.5	●	51.71 (1313)	26.63 (676)	25.08 (637)	3.75 (95)	5.16 (131)	85.5
		3	460	7.5	●	51.71 (1313)	26.63 (676)	25.08 (637)	3.75 (95)	5.16 (131)	85.5
150S100-5	184	3	460	10	●	59.42 (1509)	30.56 (776)	28.86 (733)	3.75 (95)	5.16 (131)	135.9
150S - Motor dia. 6 inch, 3 wire motor, 60 Hz, rated flow 150 gpm (3" NPT)											
150S75-4	146	3	230	7.5	▲	47.96 (1218)	22.25 (565)	25.71 (653)	5.63 (143)	5.60 (142)	99.9
		3	460	7.5	▲	47.96 (1218)	22.25 (565)	25.71 (653)	5.63 (143)	5.60 (142)	99.9
150S100-5	184	3	230	10	▲	52.72 (1339)	23.23 (590)	29.49 (749)	5.63 (143)	5.60 (142)	73.8
		3	460	10	▲	52.72 (1339)	23.23 (590)	29.49 (749)	5.63 (143)	5.60 (142)	73.8
150S150-6	222	3	230	15	▲	61.15 (1553)	27.88 (708)	33.27 (845)	5.63 (143)	5.60 (142)	119.7
		3	460	15	▲	61.15 (1553)	27.88 (708)	33.27 (845)	5.63 (143)	5.60 (142)	119.7
150S150-7	260	3	230	15	▲	64.93 (1649)	27.88 (708)	37.05 (941)	5.63 (143)	5.60 (142)	127.8
		3	460	15	▲	64.93 (1649)	27.88 (708)	37.05 (941)	5.63 (143)	5.60 (142)	127.8
150S150-8	297	3	230	15	▲	68.71 (1745)	27.88 (708)	40.83 (1037)	5.63 (143)	5.60 (142)	137.7
		3	460	15	▲	68.71 (1745)	27.88 (708)	40.83 (1037)	5.63 (143)	5.60 (142)	137.7
150S200-9	335	3	230	20	▲	75.44 (1916)	30.83 (783)	44.61 (1133)	5.63 (143)	5.60 (142)	141.3
		3	460	20	▲	75.44 (1916)	30.83 (783)	44.61 (1133)	5.63 (143)	5.60 (142)	141.3
150S200-10	373	3	230	20	▲	79.22 (2012)	30.83 (783)	48.39 (1229)	5.63 (143)	5.60 (142)	151.2
		3	460	20	▲	79.22 (2012)	30.83 (783)	48.39 (1229)	5.63 (143)	5.60 (142)	151.2
150S200-11	411	3	230	20	▲	83.00 (2108)	30.83 (783)	52.17 (1325)	5.63 (143)	5.60 (142)	166.5
		3	460	20	▲	83.00 (2108)	30.83 (783)	52.17 (1325)	5.63 (143)	5.60 (142)	166.5
150S250-12	448	3	230	25	▲	88.86 (2257)	32.92 (836)	55.95 (1421)	5.63 (143)	5.60 (142)	188.1
		3	460	25	▲	88.86 (2257)	32.92 (836)	55.95 (1421)	5.63 (143)	5.60 (142)	188.1
150S250-13	486	3	230	25	▲	92.64 (2353)	32.92 (836)	59.73 (1517)	5.63 (143)	5.60 (142)	201.6
		3	460	25	▲	92.64 (2353)	32.92 (836)	59.73 (1517)	5.63 (143)	5.60 (142)	201.6
150S250-14	524	3	230	25	▲	96.42 (2449)	32.92 (836)	63.51 (1613)	5.63 (143)	5.60 (142)	206.1
		3	460	25	▲	96.42 (2449)	32.92 (836)	63.51 (1613)	5.63 (143)	5.60 (142)	206.1

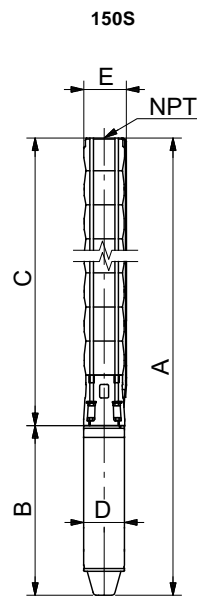

TM05 1112 2111

E = Maximum diameter of pump including cable guard and motor.

Notes:

Control box is required for 3-wire, single-phase applications. Data does not include control box.

- MS402 motor.
- MS4000 motor.
- ▲ MS6 motor.
- △ MMS6000 motor.
- ★ MMS8000 motor.
- ◆ Takes MS6 motor; not available as complete.
- ⊛ Takes MMS6000 motor; not available as complete.
- * Takes MMS8000 motor; not available as complete.
- † Takes MMS10000 motor; not available as complete.

150S (150 gpm)

Pump model	Nom. head [ft]	Ph	Volts [V]	Motor [Hp]	Dimensions					Net weight (complete) [lb]
					A [in (mm)]	B [in (mm)]	C [in (mm)]	D [in (mm)]	E [in (mm)]	
150S - Motor dia. 6 inch, 3 wire motor, 60 Hz, rated flow 150 gpm (3" NPT)										
150S300-15	562	3	230	30	▲ 102.84 (2612)	35.56 (903)	67.29 (1709)	5.63 (143)	5.60 (142)	209.7
		3	460	30	▲ 102.84 (2612)	35.56 (903)	67.29 (1709)	5.63 (143)	5.60 (142)	209.7
150S300-16	600	3	230	30	▲ 106.62 (2708)	35.56 (903)	71.07 (1805)	5.63 (143)	5.60 (142)	211.5
		3	460	30	▲ 106.62 (2708)	35.56 (903)	71.07 (1805)	5.63 (143)	5.60 (142)	211.5
150S300-17	637	3	230	30	▲ 110.4 (2804)	35.56 (903)	74.85 (1901)	5.63 (143)	5.60 (142)	216.0
		3	460	30	▲ 110.4 (2804)	35.56 (903)	74.85 (1901)	5.63 (143)	5.60 (142)	246.6
150S400-18	675	3	460	40	▲ 118.9 (3020)	40.28 (1023)	78.63 (1997)	5.63 (143)	5.60 (142)	246.6
150S400-19	713	3	460	40	▲ 122.68 (3116)	40.28 (1023)	82.41 (2093)	5.63 (143)	5.60 (142)	248.4
150S400-20	751	3	460	40	▲ 126.46 (3212)	40.28 (1023)	86.19 (2189)	5.63 (143)	5.60 (142)	291.0
150S400-21	789	3	460	40	▲ 130.24 (3308)	40.28 (1023)	89.97 (2285)	5.63 (143)	5.67 (144)	271.8
150S400-22	826	3	460	40	▲ 134.02 (3404)	40.28 (1023)	93.75 (2381)	5.63 (143)	5.67 (144)	305.9
150S400-23	864	3	460	40	▲ 137.8 (3500)	40.28 (1023)	97.52 (2477)	5.63 (143)	5.67 (144)	277.2
150S500-24	902	3	460	50	☼ 157.41 (3998)	56.11 (1425)	101.3 (2573)	5.67 (144)	5.60 (142)	411.8
150S500-25	940	3	460	50	☼ 161.19 (4094)	56.11 (1425)	105.08 (2669)	5.67 (144)	5.60 (142)	419.0
150S500-26	977	3	460	50	☼ 164.97 (4190)	56.11 (1425)	108.86 (2765)	5.67 (144)	5.60 (142)	426.2
150S500-27	1015	3	460	50	☼ 168.75 (4286)	56.11 (1425)	112.64 (2861)	5.67 (144)	5.60 (142)	433.4
150S500-28	1053	3	460	50	☼ 172.52 (4382)	56.11 (1425)	116.42 (2957)	5.67 (144)	5.60 (142)	440.6
150S600-29DS	1091	3	460	60	—	—	129.05 (3278)	—	7.10 (181)	—
150S600-31DS	1166	3	460	60	—	—	136.61 (3470)	—	7.10 (181)	—
150S600-33DS	1242	3	460	60	—	—	144.17 (3662)	—	7.10 (181)	—

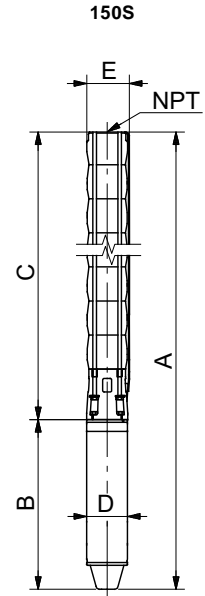

TM05 1112 2111

E = Maximum diameter of pump including cable guard and motor.

150S - Motor dia. 8 inch, 3 wire motor, 60 Hz, rated flow 150 gpm (3" NPT)										
150S500-24	902	3	460	50	* 148.12 (3762)	45.67 (1160)	102.45 (2602)	7.56 (192)	7.56 (192)	484.5
150S500-25	940	3	460	50	* 151.89 (3858)	45.67 (1160)	106.23 (2698)	7.56 (192)	7.56 (192)	491.7
150S500-26	977	3	460	50	* 155.67 (3954)	45.67 (1160)	110.00 (2794)	7.56 (192)	7.56 (192)	498.9
150S500-27	1015	3	460	50	* 159.45 (4050)	45.67 (1160)	113.78 (2890)	7.56 (192)	7.56 (192)	506.1
150S500-28	1053	3	460	50	* 163.23 (4146)	45.67 (1160)	117.56 (2986)	7.56 (192)	7.56 (192)	513.3
150S600-29DS	1091	3	460	60	* 177.92 (4519)	50.00 (1270)	127.92 (3249)	7.56 (192)	7.56 (192)	612.7
150S600-31DS	1166	3	460	60	* 185.48 (4711)	50.00 (1270)	135.48 (3441)	7.56 (192)	7.56 (192)	623.7
150S600-33DS	1242	3	460	60	* 193.04 (4903)	50.00 (1270)	143.04 (3633)	7.56 (192)	7.56 (192)	639.1
150S750-36DS	1355	3	460	75	* 207.52 (5271)	53.15 (1350)	154.38 (3921)	7.56 (192)	7.56 (192)	689.2
150S750-39DS	1469	3	460	75	* 218.86 (5559)	53.15 (1350)	165.71 (4209)	7.56 (192)	7.56 (192)	704.6

Notes:
Control box is required for 3-wire, single-phase applications. Data does not include control box.
DS designation = Built into sleeve, 3" NPT, 8" minimum well diameter.

- MS402 motor.
- MS4000 motor.
- ▲ MS6 motor.
- ∧ MMS6000 motor.
- ★ MMS8000 motor.
- ◆ Takes MS6 motor; not available as complete.
- ☼ Takes MMS6000 motor; not available as complete.
- * Takes MMS8000 motor; not available as complete.
- † Takes MMS10000 motor; not available as complete.

230S (230 gpm)

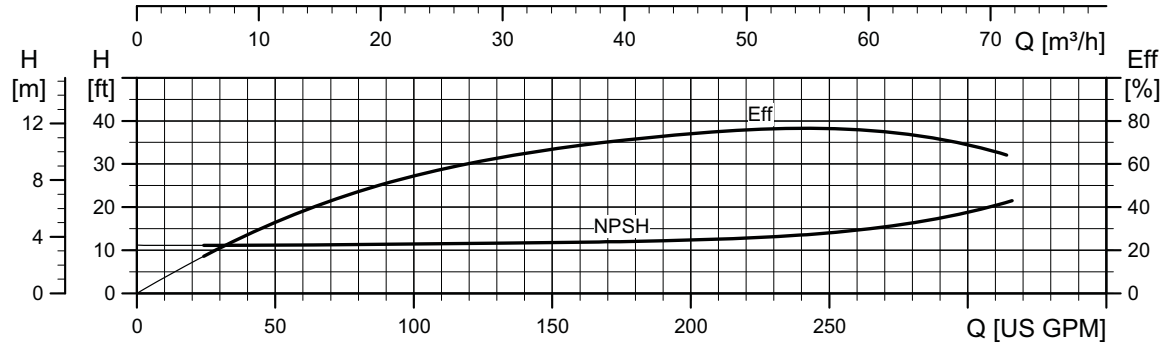
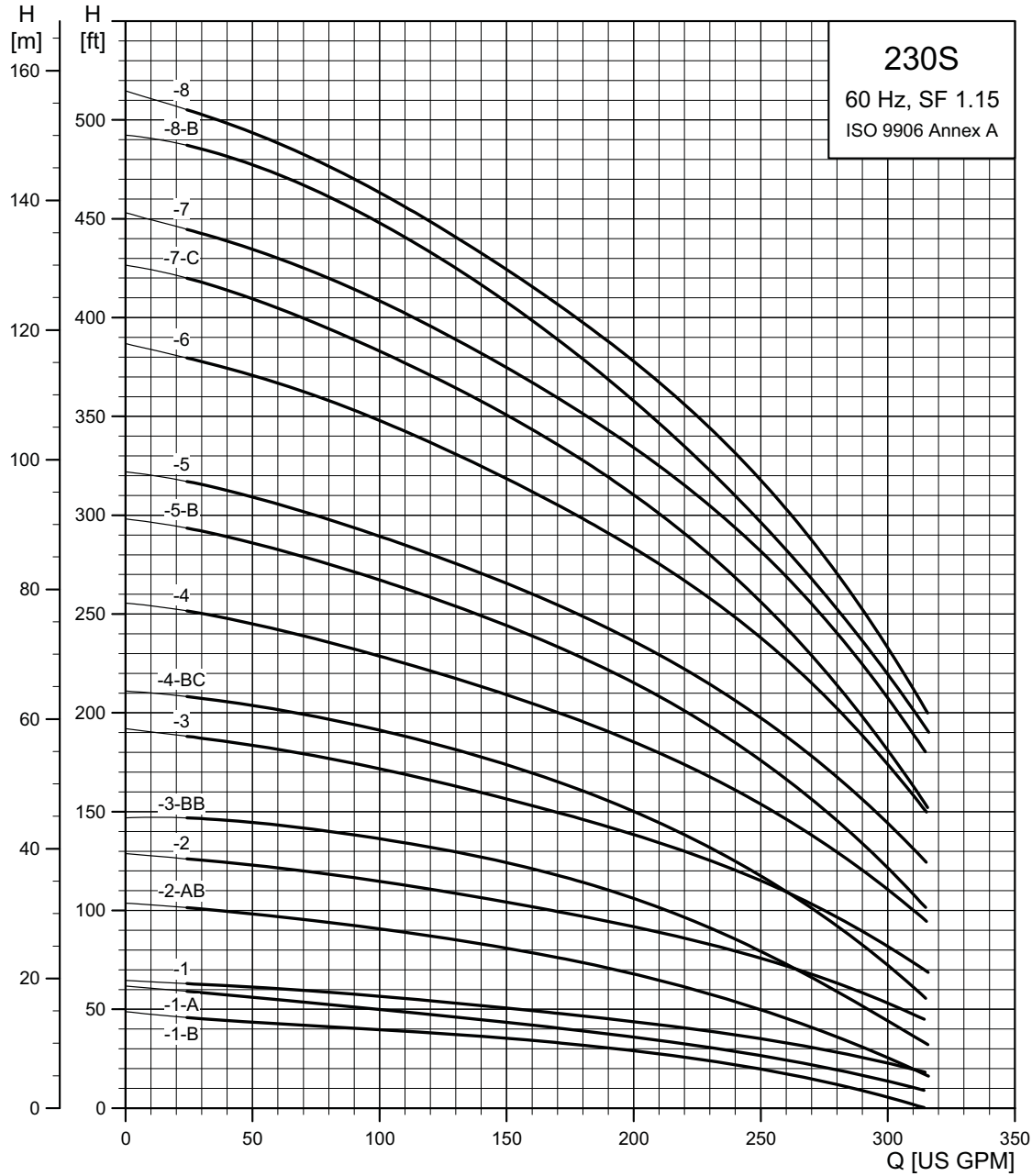

TM05 0243 0312

230S (230 gpm)

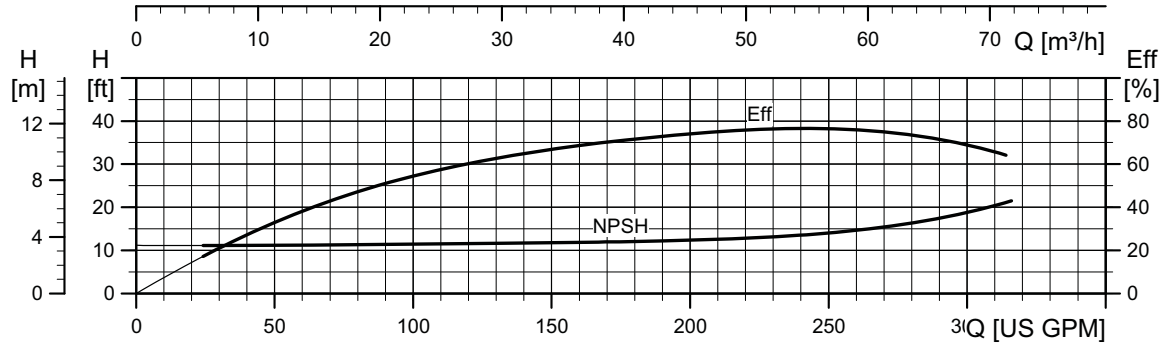
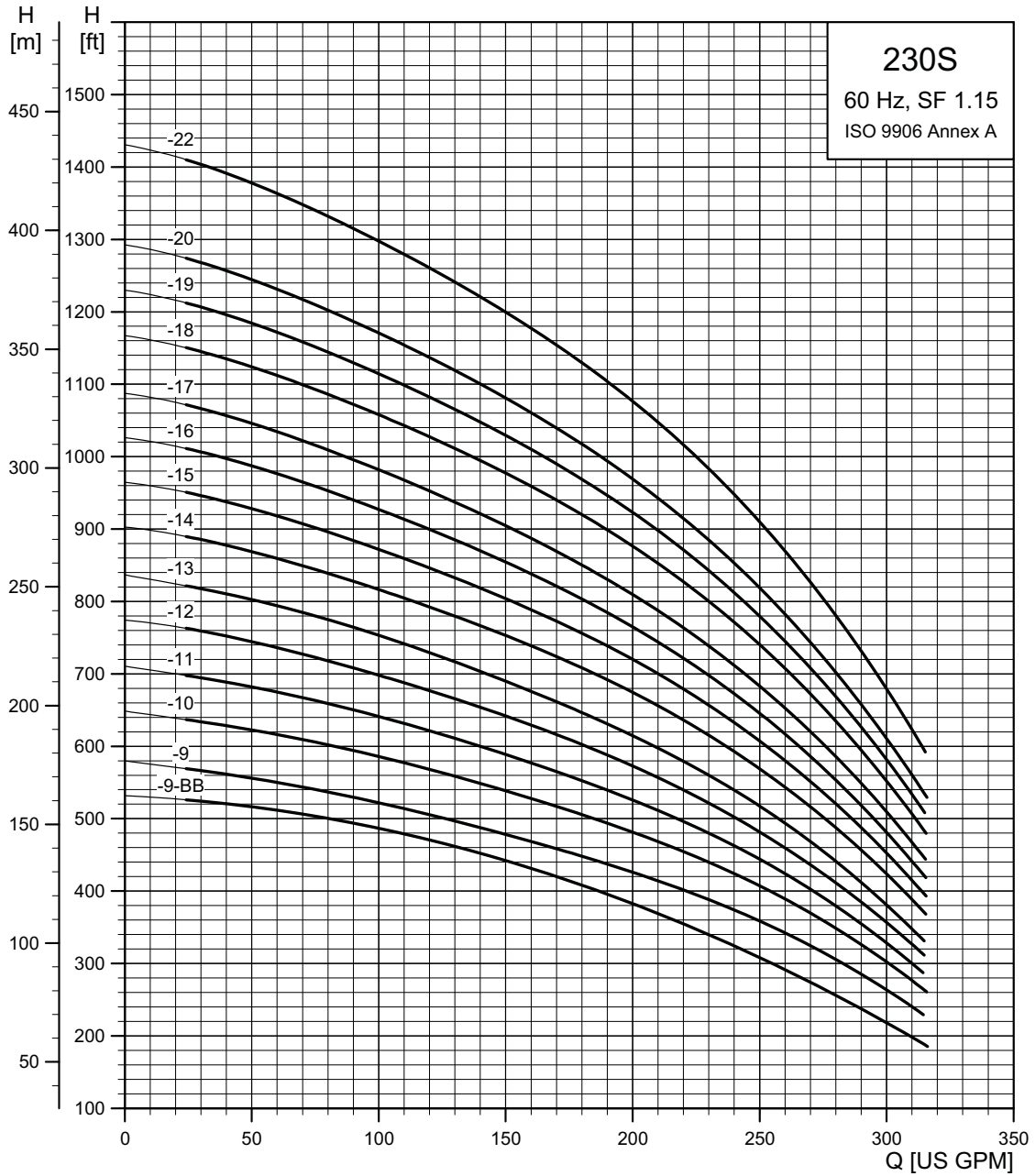

TM05 0244 0312

230S (230 gpm) pump power requirement (P2)

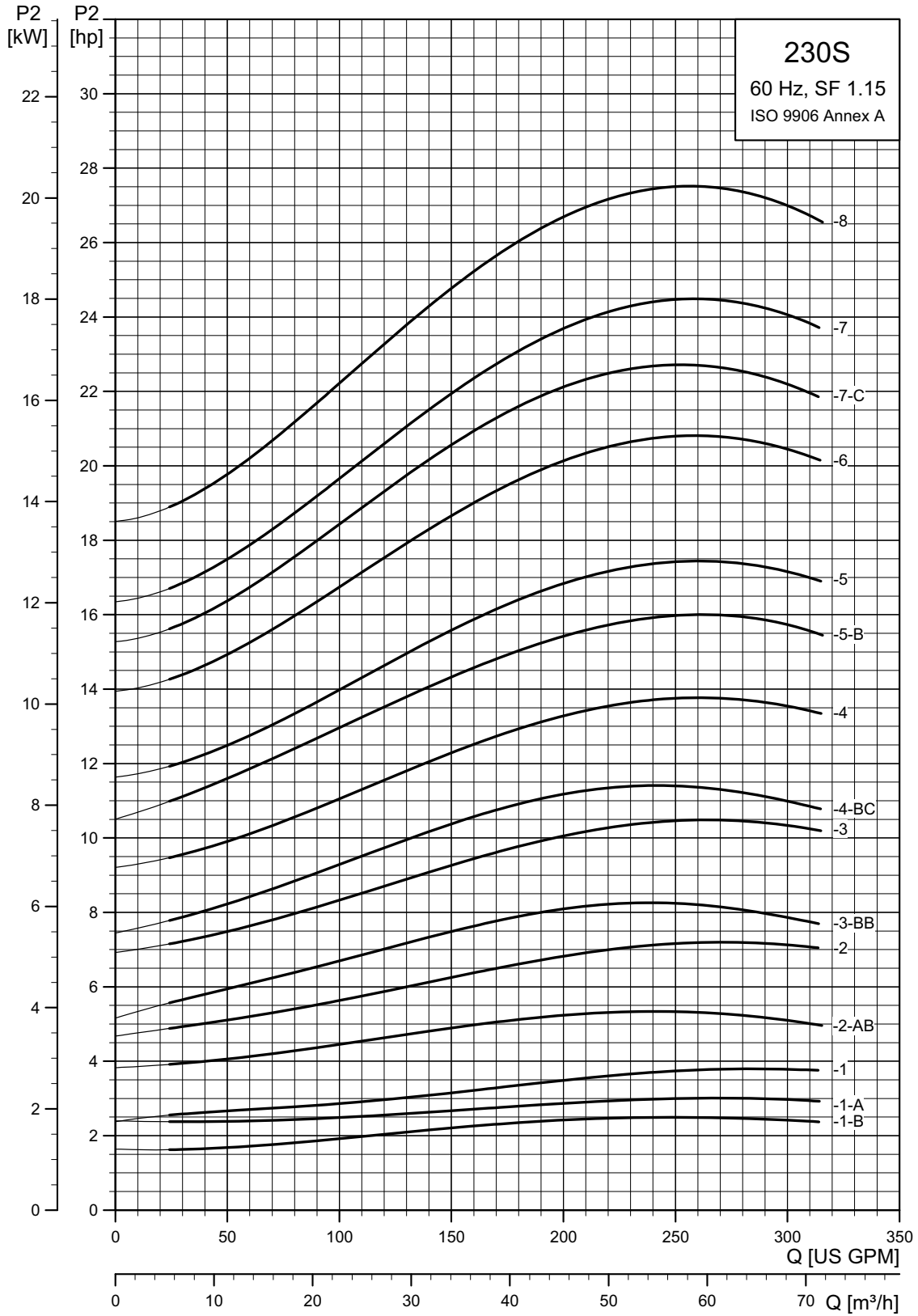

TN05 0245 0112

230S (230 gpm) pump power requirement (P2)

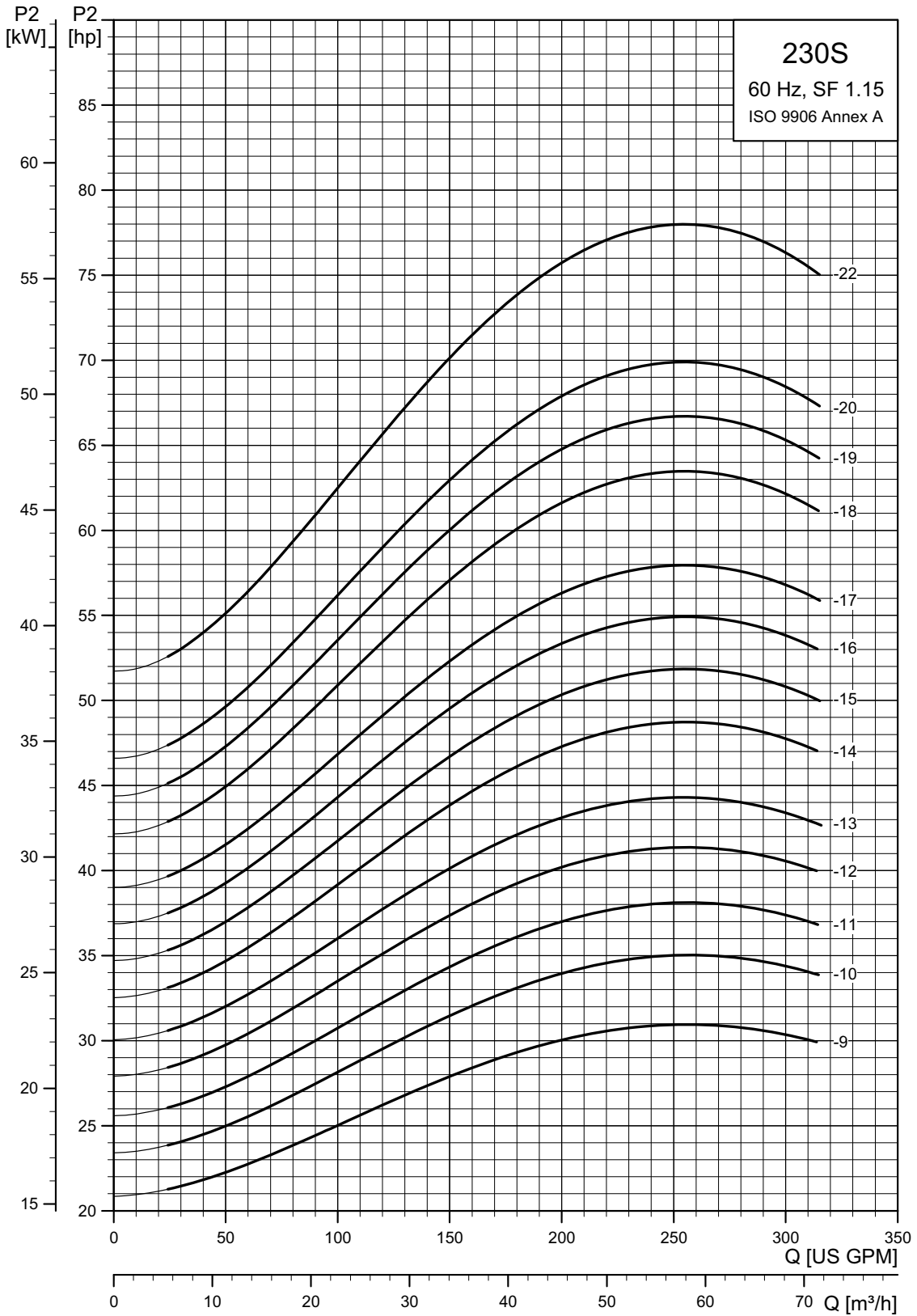

TM05 0246 0112

230S (230 gpm)

Pump model	Nom. head [ft]	Ph	Volts [V]	Motor [Hp]	Dimensions					Net weight (complete) [lb]	
					A [in (mm)]	B [in (mm)]	C [in (mm)]	D [in (mm)]	E [in (mm)]		
230S - Motor dia. 4 inch, 3 wire motor, 60 Hz, rated flow 230 gpm (3" NPT)											
230S20-1B	24	1	230	2	●	33.90 (861)	19.57 (497)	14.34 (364)	3.75 (95)	5.75 (146)	49.5
		3	230	2	●	25.67 (751)	15.24 (387)	14.34 (364)	3.75 (95)	5.75 (146)	49.5
		3	460	2	■	25.67 (751)	15.24 (387)	14.34 (364)	3.75 (95)	5.75 (146)	49.5
230S30-1A	30	1	230	3	●	37.05 (941)	22.72 (577)	14.34 (364)	3.75 (95)	5.75 (146)	49.5
		3	230	3	●	46.65 (1185)	17.96 (456)	14.34 (364)	3.75 (95)	5.75 (146)	49.5
		3	460	3	●	46.65 (1185)	17.96 (456)	14.34 (364)	3.75 (95)	5.75 (146)	49.5
230S50-1	37	1	230	5	●	40.98 (1041)	26.65 (677)	14.34 (364)	3.75 (95)	5.75 (146)	49.5
		3	230	5	●	37.01 (940)	22.69 (576)	14.34 (364)	3.75 (95)	5.75 (146)	49.5
		3	460	5	●	37.01 (940)	22.69 (576)	14.34 (364)	3.75 (95)	5.75 (146)	49.5
230S50-2AB	56	1	230	5	●	45.43 (1154)	26.65 (677)	18.78 (477)	3.75 (95)	5.75 (146)	49.5
		3	230	5	●	41.46 (1053)	22.69 (576)	18.78 (477)	3.75 (95)	5.75 (146)	79.2
		3	460	5	●	41.46 (1053)	22.69 (576)	18.78 (477)	3.75 (95)	5.75 (146)	79.2
230S75-2	80	3	230	7.5	●	45.39 (1153)	26.63 (676)	23.23 (590)	3.75 (95)	5.75 (146)	79.2
		3	460	7.5	●	45.39 (1153)	26.63 (676)	23.23 (590)	3.75 (95)	5.75 (146)	79.2
230S75-3BB	90	3	230	7.5	●	49.84 (1266)	26.63 (676)	23.23 (590)	3.75 (95)	5.75 (146)	126.0
		3	460	7.5	●	49.84 (1266)	26.63 (676)	23.23 (590)	3.75 (95)	5.75 (146)	126.0
230S100-3	123	3	460	10	●	53.78 (1366)	30.56 (776)	23.23 (590)	3.75 (95)	5.75 (146)	126.0
230S100-4BC	131	3	460	10	●	53.78 (1366)	30.56 (776)	23.23 (590)	3.75 (95)	5.75 (146)	144.9
230S - Motor dia. 6 inch, 3 wire motor, 60 Hz, rated flow 230 gpm (3" NPT)											
230S75-2	80	3	230	7.5	▲	41.65 (1058)	22.25 (565)	19.41 (493)	5.63 (143)	5.99 (152)	111.6
		3	460	7.5	▲	41.65 (1058)	22.25 (565)	19.41 (493)	5.63 (143)	5.99 (152)	111.6
230S75-3BB	90	3	230	7.5	▲	46.10 (1171)	22.25 (565)	23.86 (606)	5.63 (143)	5.99 (152)	131.4
		3	460	7.5	▲	46.10 (1171)	22.25 (565)	23.86 (606)	5.63 (143)	5.99 (152)	131.4
230S100-3	123	3	230	10	▲	47.09 (1196)	23.23 (590)	23.86 (606)	5.63 (143)	5.99 (152)	126.0
		3	460	10	▲	47.09 (1196)	23.23 (590)	23.86 (606)	5.63 (143)	5.99 (152)	126.0
230S100-4BC	131	3	230	10	▲	51.54 (1309)	23.23 (590)	28.31 (719)	5.63 (143)	5.99 (152)	144.9
		3	460	10	▲	51.54 (1309)	23.23 (590)	28.31 (719)	5.63 (143)	5.99 (152)	144.9
230S150-4	166	3	230	15	▲	56.19 (1427)	27.88 (708)	28.31 (719)	5.63 (143)	5.99 (152)	144.9
		3	460	15	▲	56.19 (1427)	27.88 (708)	28.31 (719)	5.63 (143)	5.99 (152)	144.9
230S150-5B	195	3	230	15	▲	60.63 (1540)	27.88 (708)	32.76 (832)	5.63 (143)	5.99 (152)	161.1
		3	460	15	▲	60.63 (1540)	27.88 (708)	32.76 (832)	5.63 (143)	5.99 (152)	161.1
230S200-5	208	3	230	20	▲	63.59 (1615)	30.83 (783)	32.76 (832)	5.63 (143)	5.99 (152)	161.1
		3	460	20	▲	63.59 (1615)	30.83 (783)	32.76 (832)	5.63 (143)	5.99 (152)	161.1
230S200-6	251	3	230	20	▲	68.04 (1728)	30.83 (783)	37.21 (945)	5.63 (143)	5.99 (152)	167.4
		3	460	20	▲	68.04 (1728)	30.83 (783)	37.21 (945)	5.63 (143)	5.99 (152)	167.4
230S200-7C	276	3	230	20	▲	72.49 (1841)	30.83 (783)	41.66 (1058)	5.63 (143)	5.99 (152)	181.8
		3	460	20	▲	72.49 (1841)	30.83 (783)	41.66 (1058)	5.63 (143)	5.99 (152)	181.8

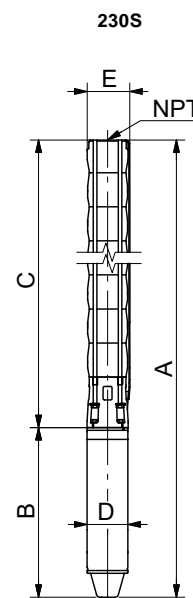

E = Maximum diameter of pump including cable guard and motor.

TM05 1112 2111

Notes:

Control box is required for 3-wire, single-phase applications. Data does not include control box.

- MS402 motor.
- MS4000 motor.
- ▲ MS6 motor.
- △ MMS6000 motor.
- ★ MMS8000 motor.
- ◆ Takes MS6 motor; not available as complete.
- ⊛ Takes MMS6000 motor; not available as complete.
- * Takes MMS8000 motor; not available as complete.
- † Takes MMS10000 motor; not available as complete.

230S (230 gpm)

Pump model	Nom. head [ft]	Ph	Volts [V]	Motor [Hp]	Dimensions					Net weight (complete) [lb]
					A	B	C	D	E	
					[in (mm)]	[in (mm)]	[in (mm)]	[in (mm)]	[in (mm)]	
230S - Motor dia. 6 inch, 3 wire motor, 60 Hz, rated flow 230 gpm (3" NPT)										
230S250-7	294	3	230	25 ▲	74.65 (1896)	33.00 (838)	41.66 (1058)	5.63 (143)	5.99 (152)	149.9
		3	460	25 ▲	74.65 (1896)	33.00 (838)	41.66 (1058)	5.63 (143)	5.99 (152)	181.8
230S250-8B	329	3	230	25 ▲	79.10 (2009)	33.00 (838)	46.11 (1171)	5.63 (143)	5.99 (152)	188.1
		3	460	25 ▲	79.10 (2009)	33.00 (838)	46.11 (1171)	5.63 (143)	5.99 (152)	188.1
230S250-8	336	3	230	25 ▲	79.10 (2009)	33.00 (838)	46.11 (1171)	5.63 (143)	5.99 (152)	188.1
		3	460	25 ▲	79.10 (2009)	33.00 (838)	46.11 (1171)	5.63 (143)	5.99 (152)	188.1
230S250-9BB	352	3	230	25 ▲	83.55 (2122)	33.00 (838)	50.56 (1284)	5.63 (143)	5.99 (152)	205.2
		3	460	25 ▲	83.55 (2122)	33.00 (838)	50.56 (1284)	5.63 (143)	5.99 (152)	205.2
230S300-9	379	3	230	30 ▲	86.11 (2187)	35.56 (903)	50.56 (1284)	5.63 (143)	5.99 (152)	205.2
		3	460	30 ▲	86.11 (2187)	35.56 (903)	50.56 (1284)	5.63 (143)	5.99 (152)	205.2
230S400-10	422	3	460	30 ▲	95.28 (2420)	40.28 (1023)	55.00 (1397)	5.63 (143)	5.99 (152)	241.2
230S400-11	465	3	460	40 ▲	99.73 (2533)	40.28 (1023)	59.45 (1510)	5.63 (143)	5.99 (152)	245.7
230S400-12	507	3	460	40 ▲	104.18 (2646)	40.28 (1023)	63.9 (1623)	5.63 (143)	5.99 (152)	251.1
230S400-13	550	3	460	40 ▲	108.63 (2759)	40.28 (1023)	68.35 (1736)	5.63 (143)	5.99 (152)	255.6
230S500-14	593	3	460	50 ▲	132.17 (3357)	56.11 (1425)	76.07 (1932)	5.67 (144)	5.99 (152)	356.0
230S500-15	635	3	460	50 ▲	136.62 (3470)	56.11 (1425)	80.52 (2045)	5.67 (144)	5.99 (152)	360.5
230S500-16	678	3	460	50 ▲	141.07 (3583)	56.11 (1425)	84.97 (2158)	5.67 (144)	5.99 (152)	365.0
230S600-17	721	3	460	60 ▲	—	—	88.54 (2249)	—	5.99 (152)	—
230S600-18	763	3	460	60 ▲	—	—	92.99 (2362)	—	5.99 (152)	—
230S600-19	806	3	460	60 ▲	—	—	97.44 (2475)	—	7.56 (192)	—

230S - Motor dia. 8 inch, 3 wire motor, 60 Hz, rated flow 230 gpm (3" NPT)										
230S600-17	721	3	460	60 ★	137.41 (3490)	50.00 (1270)	87.41 (2220)	7.56 (192)	7.56 (192)	546.0
230S600-18	763	3	460	60 ★	141.86 (3690)	50.00 (1270)	91.86 (2333)	7.56 (192)	7.56 (192)	568.5
230S600-19	806	3	460	60 ★	146.3 (3716)	50.00 (1270)	96.3 (2446)	7.56 (192)	7.56 (192)	591.0
230S750-20DS	849	3	460	75 ★	153.9 (3909)	53.15 (1350)	100.75 (2559)	7.56 (192)	7.56 (192)	549.9
230S750-22DS	934	3	460	75 ★	169.22 (4298)	53.15 (1350)	116.07 (2948)	7.56 (192)	7.56 (192)	620.4

Notes:
Control box is required for 3-wire, single-phase applications. Data does not include control box.
DS designation = Built into sleeve, 4" NPT, 10" minimum well diameter.

- MS402 motor.
- MS4000 motor.
- ▲ MS6 motor.
- △ MMS6000 motor.
- ★ MMS8000 motor.
- ◆ Takes MS6 motor; not available as complete.
- ☆ Takes MMS6000 motor; not available as complete.
- * Takes MMS8000 motor; not available as complete.
- † Takes MMS10000 motor; not available as complete.

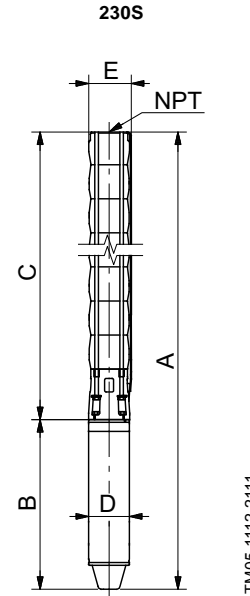

E = Maximum diameter of pump including cable guard and motor.

TM05 1112 2111

300S (300 gpm)

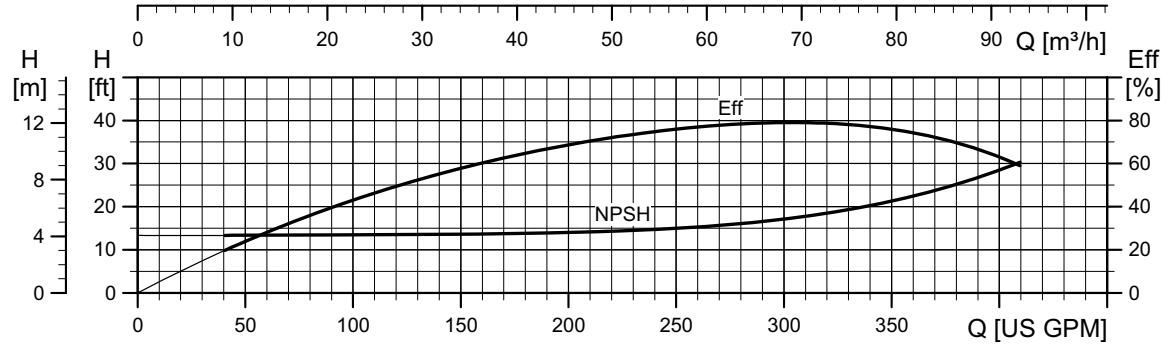
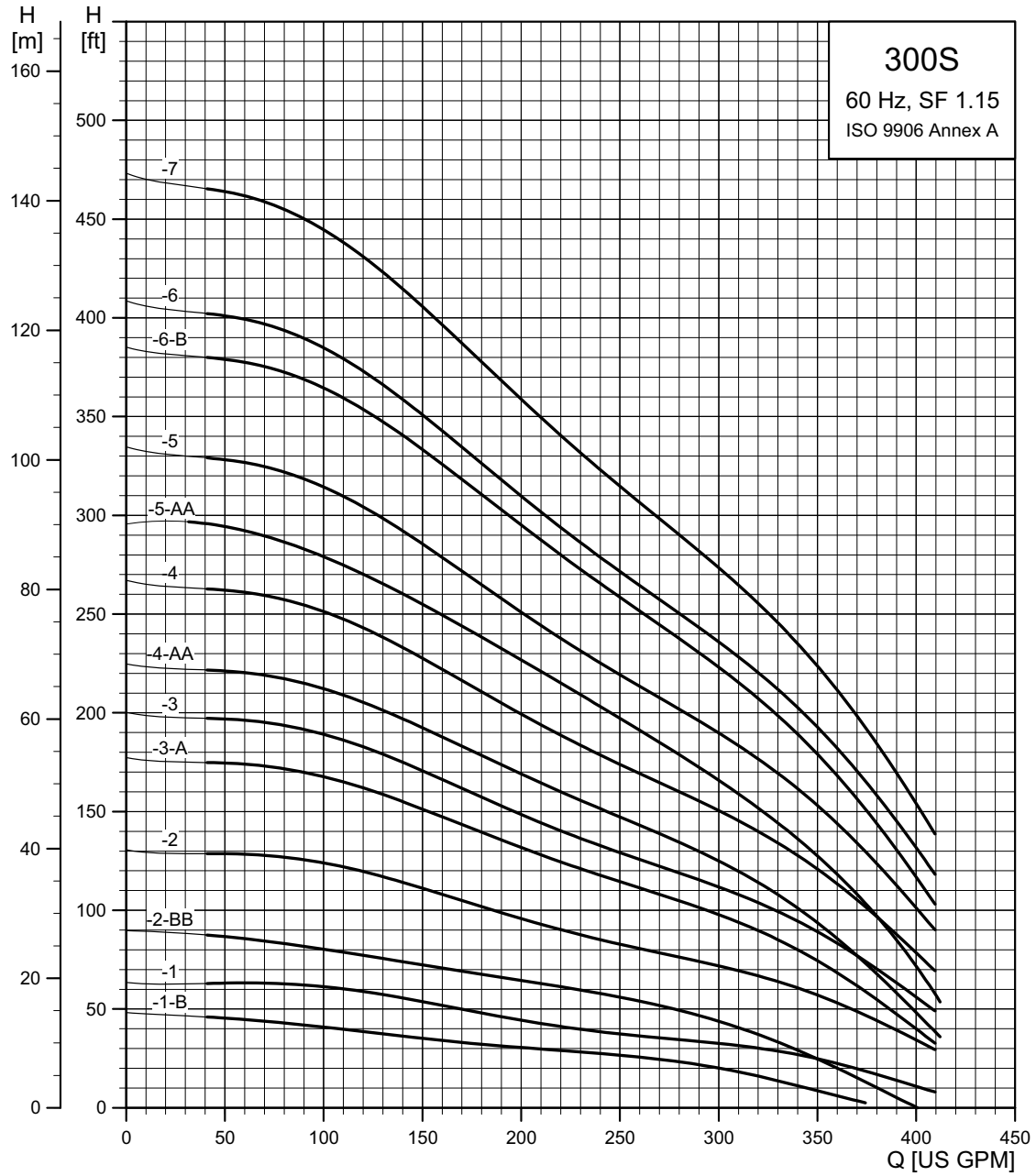

TN05 0247 0112

300S (300 gpm)

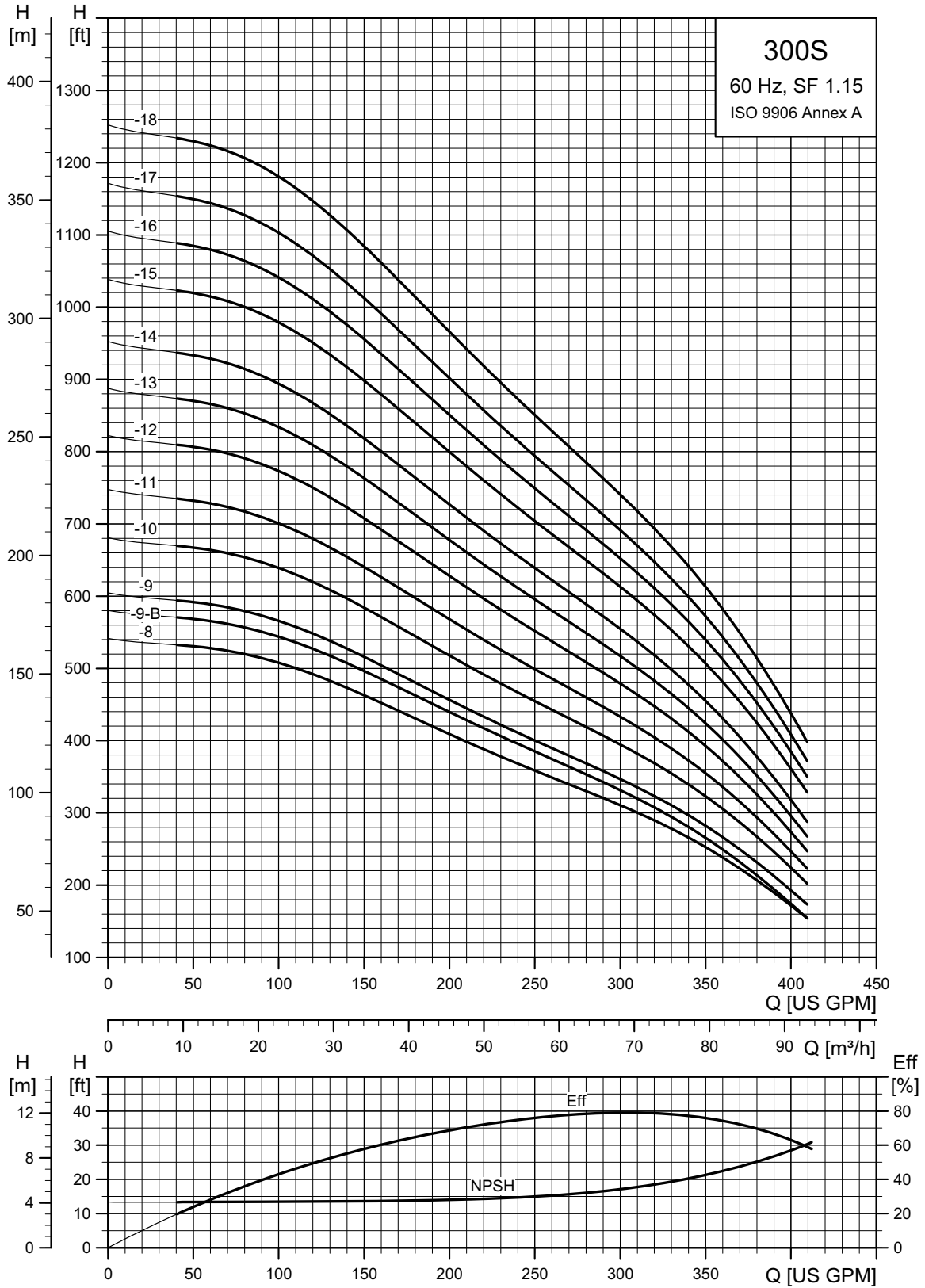

TM05 0248 0112

300S (300 gpm) pump power requirement (P2)

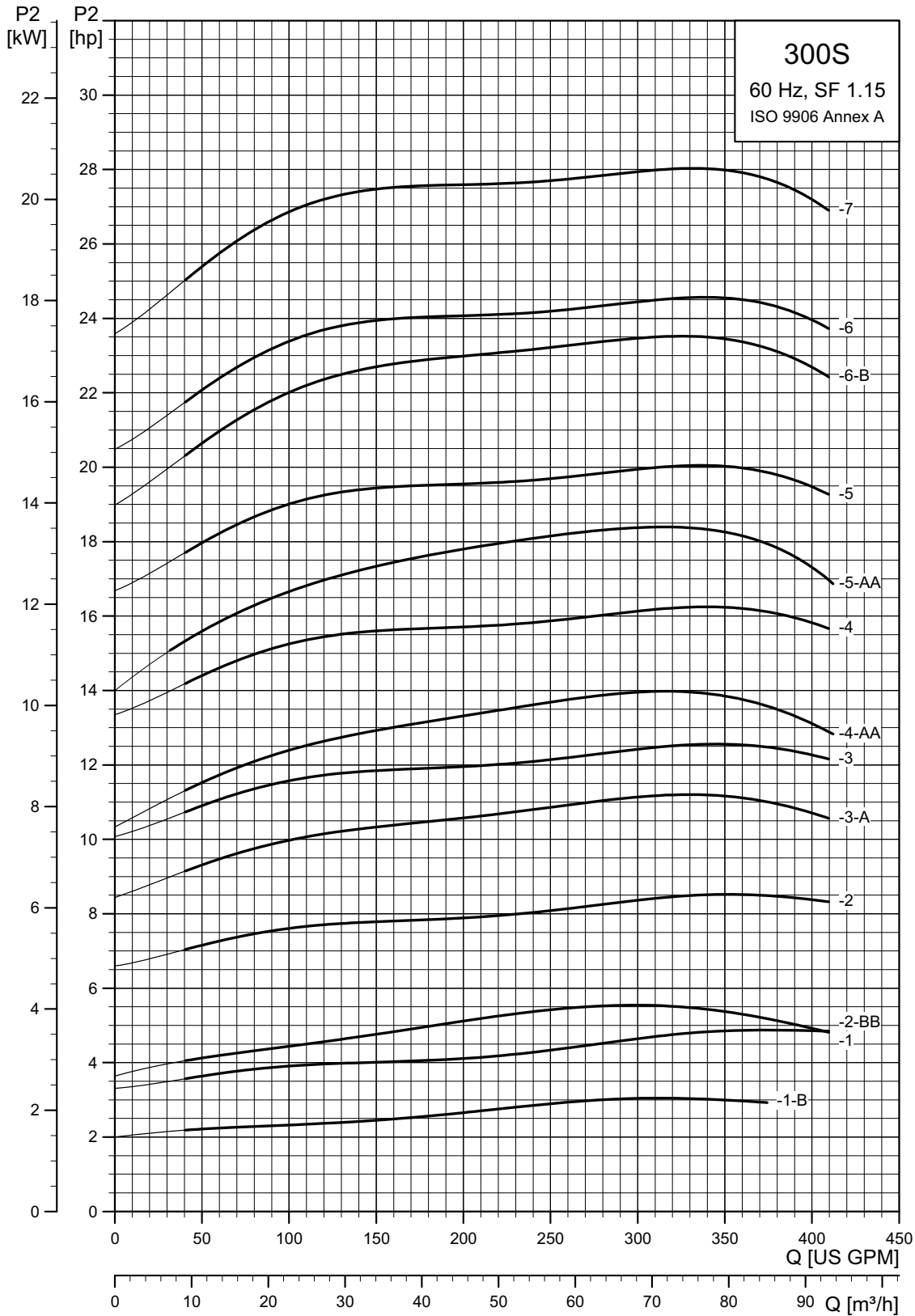

TM05 0249 0112

300S (300 gpm) pump power requirement (P2)

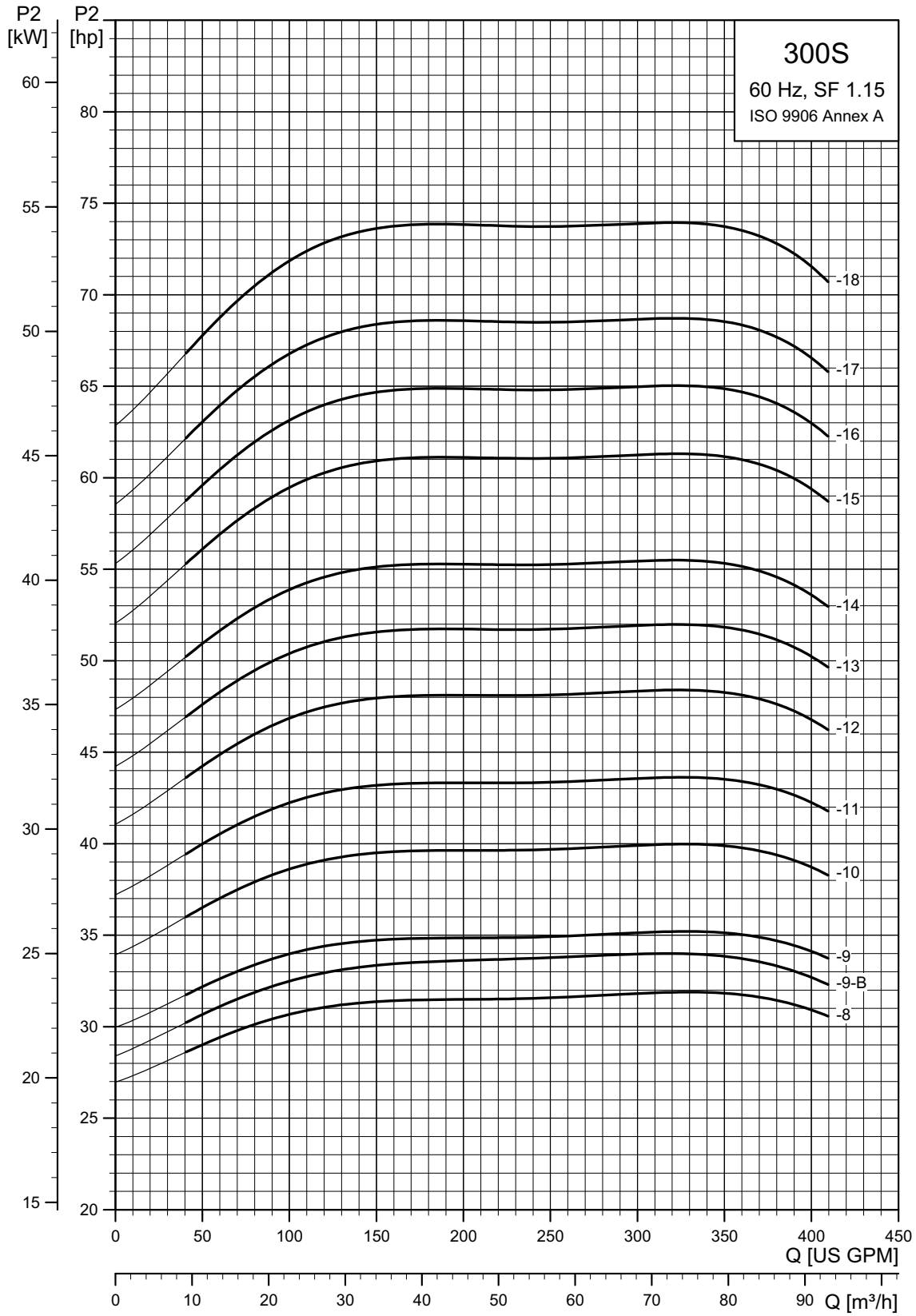

TM05 0250 0112

300S (300 gpm)

Pump model	Nom. head [ft]	Ph	Volts [V]	Motor [Hp]	Dimensions					Net weight (complete) [lb]	
					A [in (mm)]	B [in (mm)]	C [in (mm)]	D [in (mm)]	E [in (mm)]		
300S - Motor dia. 4 inch, 3 wire motor, 60 Hz, rated flow 300 gpm (3" NPT)											
300S30-1B	19	1	230	3	●	37.17 (944)	22.72 (577)	14.45 (367)	3.75 (95)	5.83 (148)	72.0
		3	230	3	●	32.41 (823)	17.96 (456)	14.45 (367)	3.75 (95)	5.83 (148)	72.0
		3	460	3	●	32.41 (823)	17.96 (456)	14.45 (367)	3.75 (95)	5.83 (148)	72.0
300S50-1	31	1	230	5	●	41.11 (1044)	26.65 (677)	14.45 (367)	3.75 (95)	5.83 (148)	74.7
		3	230	5	●	37.13 (943)	22.69 (576)	14.45 (367)	3.75 (95)	5.83 (148)	74.7
		3	460	5	●	37.13 (943)	22.69 (576)	14.45 (367)	3.75 (95)	5.83 (148)	74.7
300S50-2BB	42	1	230	5	●	45.56 (1157)	26.65 (677)	18.90 (480)	3.75 (95)	5.83 (148)	135.0
		3	230	5	●	41.58 (1056)	22.69 (576)	18.90 (480)	3.75 (95)	5.83 (148)	135.0
		3	460	5	●	41.58 (1056)	22.69 (576)	18.90 (480)	3.75 (95)	5.83 (148)	135.0
300S75-2	70	3	230	7.5	●	45.52 (1156)	26.62 (676)	18.90 (480)	3.75 (95)	5.83 (148)	101.7
		3	460	7.5	●	45.52 (1156)	26.62 (676)	18.90 (480)	3.75 (95)	5.83 (148)	101.7
300S100-3A	97	3	460	10	●	53.90 (1369)	30.56 (776)	23.35 (593)	3.75 (95)	5.83 (148)	145.8
300S - Motor dia. 6 inch, 3 wire motor, 60 Hz, rated flow 300 gpm (3" NPT)											
300S75-2	70	3	230	7.5	▲	41.78 (1061)	22.25 (565)	19.53 (496)	5.63 (143)	6.15 (156)	167.4
		3	460	7.5	▲	41.78 (1061)	22.25 (565)	19.53 (496)	5.63 (143)	6.15 (156)	167.4
300S100-3A	97	3	230	10	▲	47.21 (1199)	23.23 (590)	23.98 (609)	5.63 (143)	6.15 (156)	216.0
		3	460	10	▲	47.21 (1199)	23.23 (590)	23.98 (609)	5.63 (143)	6.15 (156)	216.0
300S150-3	110	3	230	15	▲	51.86 (1317)	27.88 (708)	23.98 (609)	5.63 (143)	6.15 (156)	216.0
		3	460	15	▲	51.86 (1317)	27.88 (708)	23.98 (609)	5.63 (143)	6.15 (156)	216.0
300S150-4AA	123	3	230	15	▲	56.30 (1430)	27.88 (708)	28.43 (722)	5.63 (143)	6.15 (156)	222.3
		3	460	15	▲	56.30 (1430)	27.88 (708)	28.43 (722)	5.63 (143)	6.15 (156)	222.3
300S150-4	149	3	230	15	▲	56.30 (1430)	27.88 (708)	28.43 (722)	5.63 (143)	6.15 (156)	222.3
		3	460	15	▲	56.30 (1430)	27.88 (708)	28.43 (722)	5.63 (143)	6.15 (156)	222.3
300S200-5AA	170	3	230	20	▲	63.71 (1618)	30.83 (783)	32.88 (835)	5.63 (143)	6.15 (156)	194.4
		3	460	20	▲	63.71 (1618)	30.83 (783)	32.88 (835)	5.63 (143)	6.15 (156)	194.4
300S200-5	188	3	230	20	▲	63.71 (1618)	30.83 (783)	32.88 (835)	5.63 (143)	6.15 (156)	194.4
		3	460	20	▲	63.71 (1618)	30.83 (783)	32.88 (835)	5.63 (143)	6.15 (156)	194.4
300S200-6B	211	3	230	20	▲	68.15 (1731)	30.83 (783)	37.33 (948)	5.63 (143)	6.15 (156)	198.0
		3	460	20	▲	68.15 (1731)	30.83 (783)	37.33 (948)	5.63 (143)	6.15 (156)	198.0
300S250-6	228	3	230	25	▲	70.32 (1786)	33.00 (838)	37.33 (948)	5.63 (143)	6.15 (156)	198.0
		3	460	25	▲	70.32 (1786)	33.00 (838)	37.33 (948)	5.63 (143)	6.15 (156)	198.0

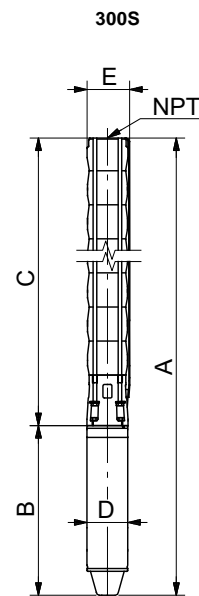

E = Maximum diameter of pump including cable guard and motor.

TM05 1112 2111

Notes:

Control box is required for 3-wire, single-phase applications. Data does not include control box.

- MS402 motor.
- MS4000 motor.
- ▲ MS6 motor.
- △ MMS6000 motor.
- ★ MMS8000 motor.
- ◆ Takes MS6 motor; not available as complete.
- ☆ Takes MMS6000 motor; not available as complete.
- * Takes MMS8000 motor; not available as complete.
- † Takes MMS10000 motor; not available as complete.

300S (300 gpm)

Pump model	Nom. head [ft]	Ph	Volts [V]	Motor [Hp]	Dimensions					Net weight (complete) [lb]
					A	B	C	D	E	
					[in (mm)]	[in (mm)]	[in (mm)]	[in (mm)]	[in (mm)]	
300S - Motor dia. 6 inch, 3 wire motor, 60 Hz, rated flow 300 gpm (4" NPT)										
300S250-7AA	249	3	230	25 ▲	74.77 (1899)	33.00 (838)	41.78 (1061)	5.63 (143)	6.15 (156)	217.8
		3	460	25 ▲	74.77 (1899)	33.00 (838)	41.78 (1061)	5.63 (143)	6.15 (156)	217.8
300S300-7	267	3	230	25 ▲	77.33 (1964)	35.56 (903)	41.78 (1061)	5.63 (143)	6.15 (156)	217.8
		3	460	25 ▲	77.33 (1964)	35.56 (903)	41.78 (1061)	5.63 (143)	6.15 (156)	217.8
300S300-8	307	3	230	30 ▲	81.78 (2077)	35.56 (903)	46.23 (1174)	5.63 (143)	6.15 (156)	224.1
		3	460	30 ▲	81.78 (2077)	35.56 (903)	46.23 (1174)	5.63 (143)	6.15 (156)	224.1
300S300-9B	329	3	230	30 ▲	86.23 (2190)	35.56 (903)	50.67 (1287)	5.63 (143)	6.15 (156)	261.0
		3	460	30 ▲	86.23 (2190)	35.56 (903)	50.67 (1287)	5.63 (143)	6.15 (156)	261.0
300S400-9	346	3	460	40 ▲	90.95 (2310)	40.28 (1023)	50.67 (1287)	5.63 (143)	6.15 (156)	296.0
300S400-10	385	3	460	40 ▲	95.40 (2423)	40.28 (1023)	55.12 (1400)	5.63 (143)	6.15 (156)	300.5
300S500-11	425	3	460	50 ⚡	115.67 (2938)	56.11 (1425)	59.57 (1513)	5.67 (144)	6.15 (156)	352.0
300S500-12	464	3	460	50 ⚡	120.12 (3051)	56.11 (1425)	64.02 (1626)	5.67 (144)	6.15 (156)	348.8
300S500-13	504	3	460	50 ⚡	124.57 (3164)	56.11 (1425)	68.47 (1739)	5.67 (144)	6.15 (156)	355.1
300S600-14	543	3	460	60 ⚡	—	—	74.06 (1881)	—	6.15 (156)	—
300S600-15	582	3	460	60 ⚡	—	—	74.06 (1881)	—	6.15 (156)	—
SP 300S - Motor dia. 8 inch, 3 wire motor, 60 Hz, rated flow 230 gpm (4" NPT)										
300S600-14	543	3	460	60 *	124.06 (3151)	50.00 (1270)	74.06 (1881)	7.56 (192)	7.56 (192)	479.4
300S600-15	582	3	460	60 *	128.51 (3264)	50.00 (1270)	78.51 (1994)	7.56 (192)	7.56 (192)	519.4
300S750-16	622	3	460	75 *	136.11 (3457)	53.15 (1350)	82.96 (2107)	7.56 (192)	7.56 (192)	569.1
300S750-17	661	3	460	75 *	140.56 (3570)	53.15 (1350)	87.41 (2220)	7.56 (192)	7.56 (192)	575.4
300S750-18	701	3	460	75 *	145.00 (3683)	53.15 (1350)	91.86 (2333)	7.56 (192)	7.56 (192)	581.7

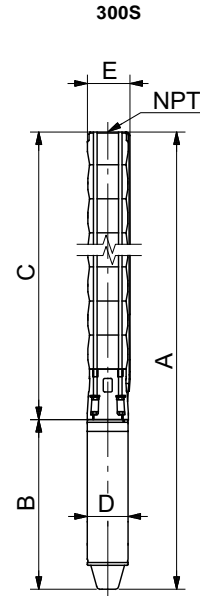

TM05 1112 2111

E = Maximum diameter of pump including cable guard and motor.

Notes:

Control box is required for 3-wire, single-phase applications. Data does not include control box.

- MS402 motor.
- MS4000 motor.
- ▲ MS6 motor.
- △ MMS6000 motor.
- ★ MMS8000 motor.
- ◆ Takes MS6 motor; not available as complete.
- ⚡ Takes MMS6000 motor; not available as complete.
- * Takes MMS8000 motor; not available as complete.
- † Takes MMS10000 motor; not available as complete.

385S (385 gpm)

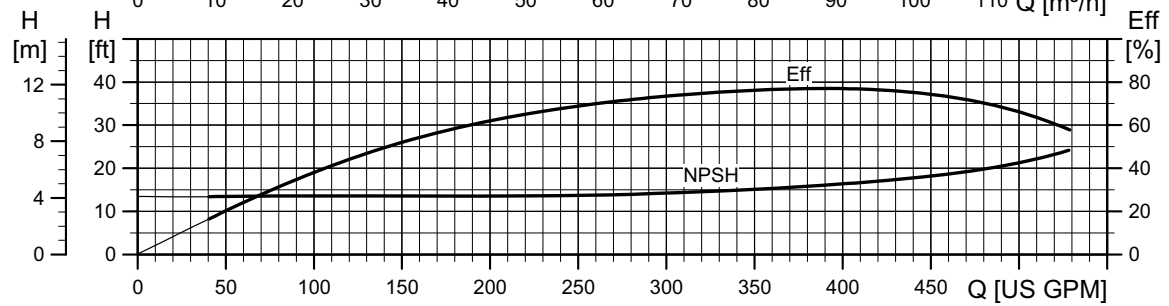
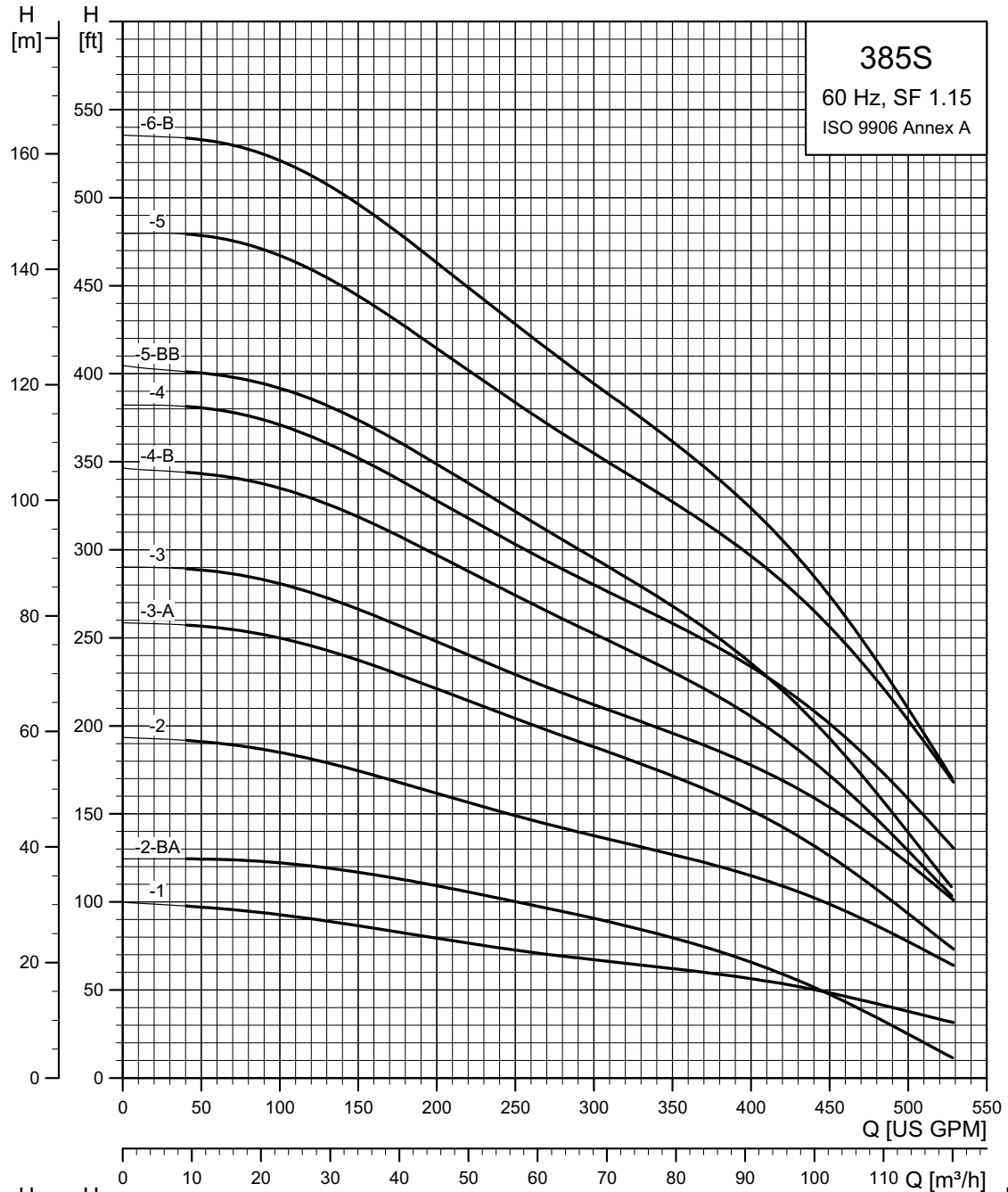

TM05 0251 0 112

385S (385 gpm)

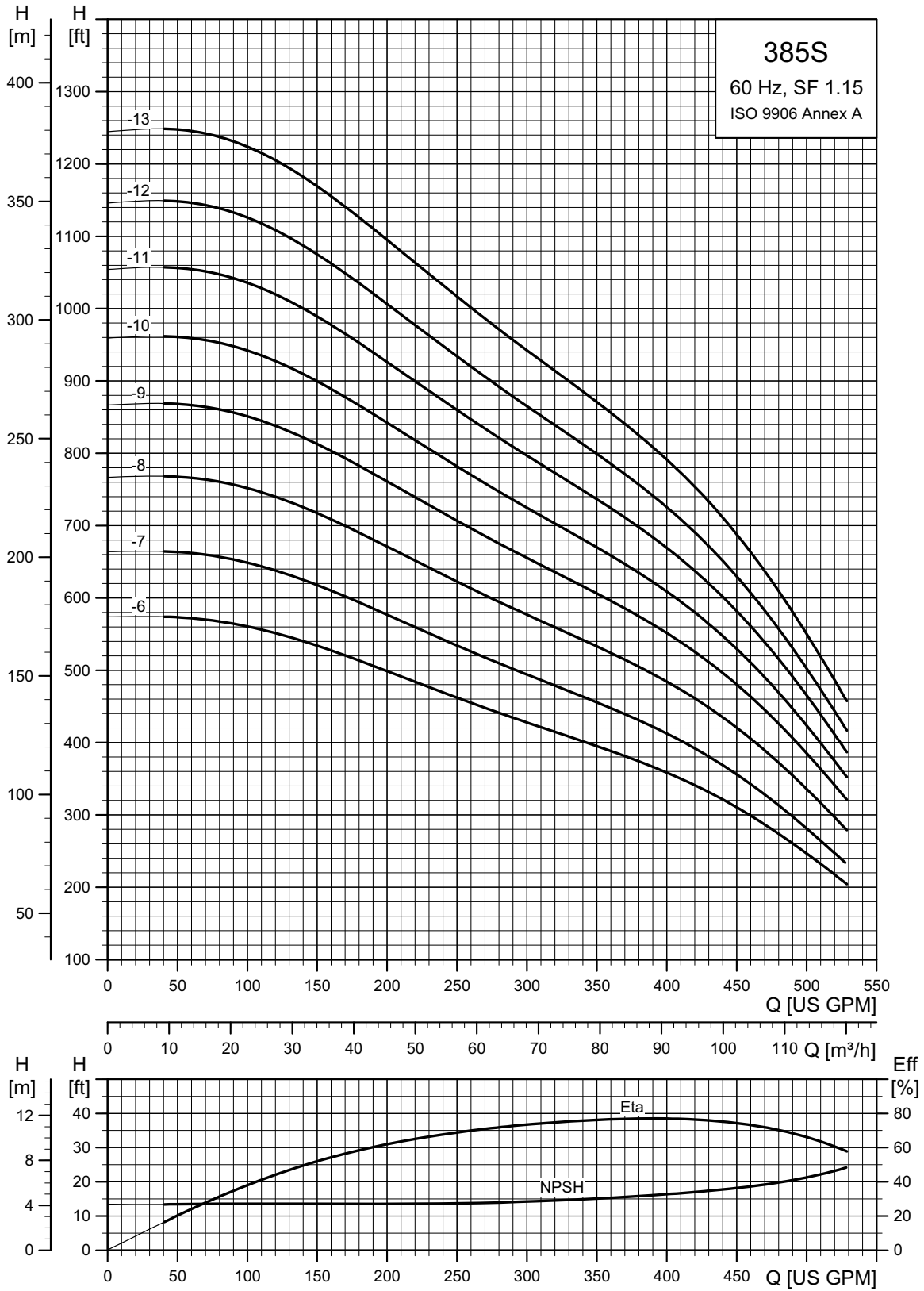

TM05 0252 0112

385S (385 gpm) pump power requirement (P2)

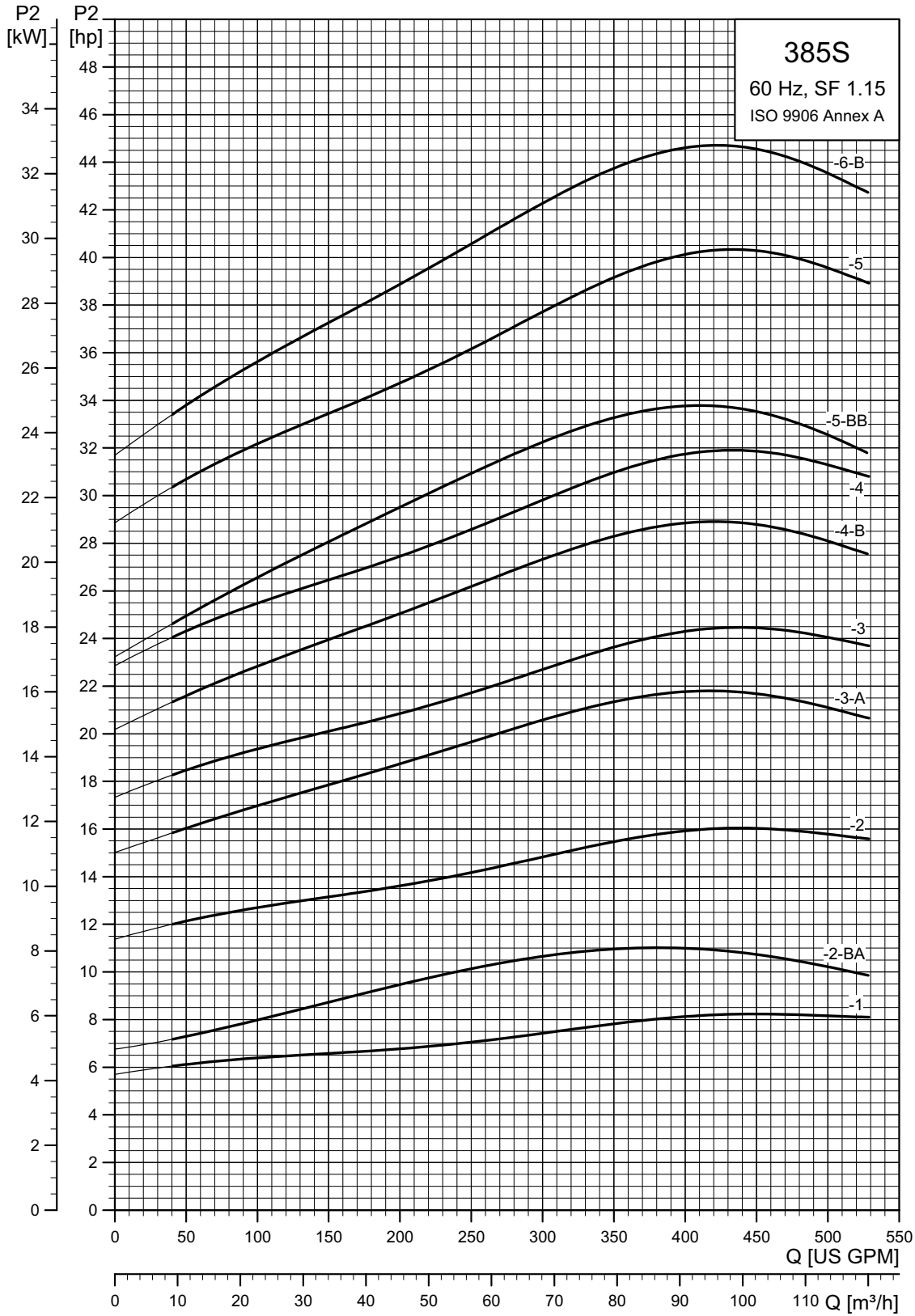

TM05 0253 0112

385S (385 gpm) pump power requirement (P2)

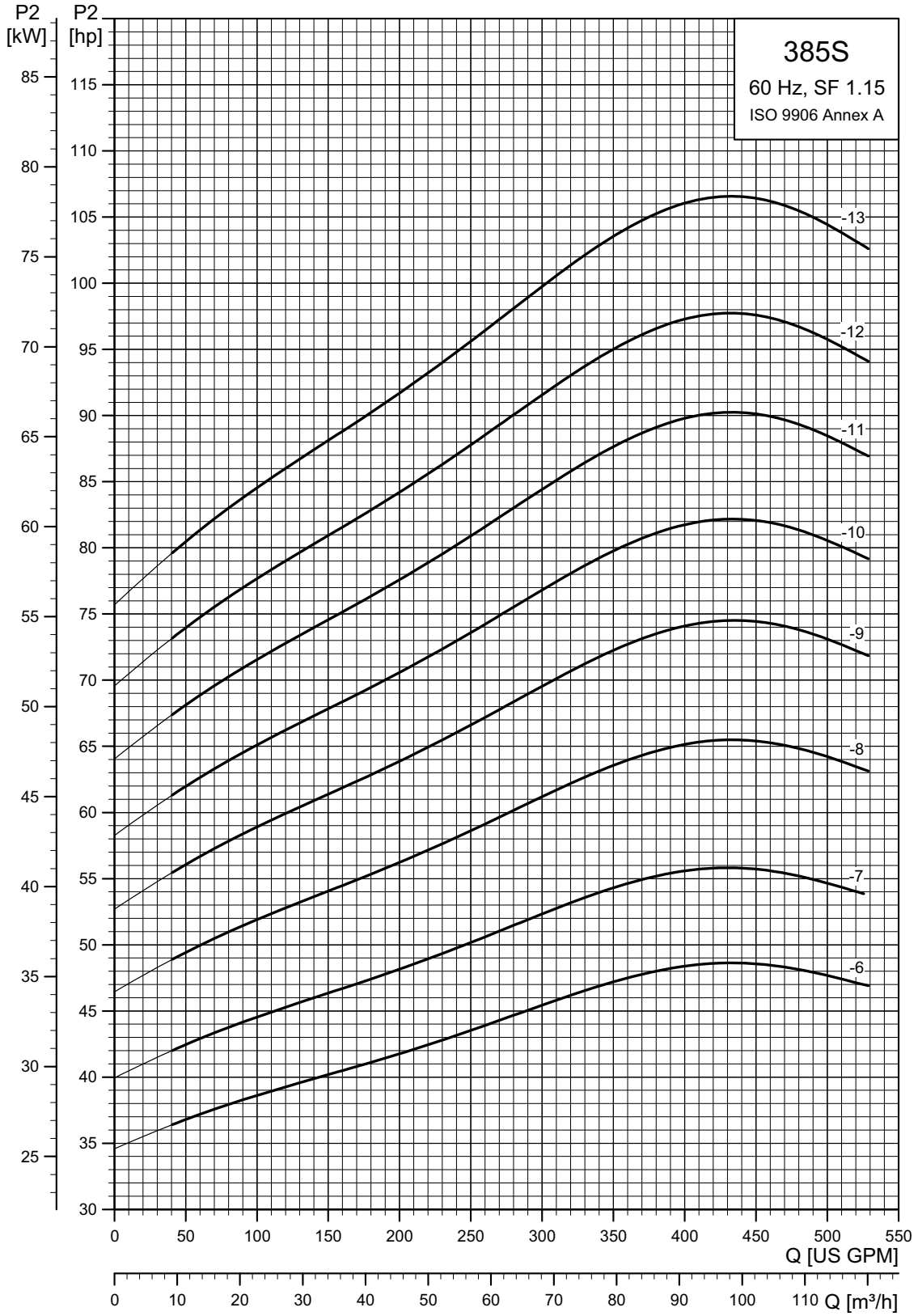

TM05 0254 0112

385S (385 gpm)

Pump model	Nom. head [ft]	Ph	Volts [V]	Motor [Hp]	Dimensions					Net weight (complete) [lb]
					A [in (mm)]	B [in (mm)]	C [in (mm)]	D [in (mm)]	E [in (mm)]	
385S - Motor dia. 6 inch, 3 wire motor, 60 Hz, rated flow 385 gpm (4" NPT)										
385S75-1	57	3	230	7.5 ▲	46.58 (1183)	22.25 (565)	24.34 (618)	5.63 (143)	7.01 (178)	135.9
		3	460	7.5 ▲	46.58 (1183)	22.25 (565)	24.34 (618)	5.63 (143)	7.01 (178)	135.9
385S100-2BA	69	3	230	10 ▲	52.6 (1336)	23.23 (590)	29.38 (746)	5.63 (143)	7.01 (178)	169.2
		3	460	10 ▲	52.6 (1336)	23.23 (590)	29.38 (746)	5.63 (143)	7.01 (178)	169.2
385S150-2	117	3	230	18 ▲	57.25 (1454)	27.88 (708)	29.38 (746)	5.63 (143)	7.01 (178)	169.2
		3	460	18 ▲	57.25 (1454)	27.88 (708)	29.38 (746)	5.63 (143)	7.01 (178)	169.2
385S200-3A	155	3	230	20 ▲	65.24 (1657)	30.83 (783)	34.41 (874)	5.63 (143)	7.01 (178)	188.1
		3	460	20 ▲	65.24 (1657)	30.83 (783)	34.41 (874)	5.63 (143)	7.01 (178)	188.1
385S250-3	177	3	230	25 ▲	67.41 (1712)	33.00 (838)	34.41 (874)	5.63 (143)	7.01 (178)	188.1
		3	460	25 ▲	67.41 (1712)	33.00 (838)	34.41 (874)	5.63 (143)	7.01 (178)	188.1
385S250-4B	210	3	230	25 ▲	72.45 (1840)	33.00 (838)	39.45 (1002)	5.63 (143)	7.01 (178)	239.4
		3	460	25 ▲	72.45 (1840)	33.00 (838)	39.45 (1002)	5.63 (143)	7.01 (178)	239.4
385S300-4	237	3	230	30 ▲	75.00 (1905)	35.56 (903)	39.45 (1002)	5.63 (143)	7.01 (178)	239.4
		3	460	30 ▲	75.00 (1905)	35.56 (903)	39.45 (1002)	5.63 (143)	7.01 (178)	239.4
385S300-5BB	343	3	230	30 ▲	80.04 (2033)	35.56 (903)	44.49 (1130)	5.63 (143)	7.01 (178)	247.5
		3	460	30 ▲	80.04 (2033)	35.56 (903)	44.49 (1130)	5.63 (143)	7.01 (178)	247.5
385S400-5	297	3	460	40 ▲	84.77 (2153)	40.28 (1023)	44.49 (1130)	5.63 (143)	7.01 (178)	247.5
385S400-6B	330	3	460	40 ▲	89.81 (2281)	40.28 (1023)	49.53 (1258)	5.63 (143)	7.01 (178)	252.0
385S500-6	357	3	460	50 ☼	110.99 (2825)	56.11 (1425)	54.88 (1394)	5.67 (144)	7.88 (200)	—
385S500-7A	400	3	460	50 ☼	110.99 (2825)	56.11 (1425)	54.88 (1394)	5.67 (144)	7.88 (200)	—
385S600-7	416	3	460	60 ◆	—	—	55.12 (1400)	—	7.88 (200)	—
385S600-8	476	3	460	60 ◆	—	—	55.12 (1400)	—	7.88 (200)	—

385S - Motor dia. 8 inch, 3 wire motor, 60 Hz, rated flow 385 gpm (4" NPT)										
385S400-6B	330	3	460	40 *	93.78 (2382)	43.71 (1110)	50.08 (1272)	7.56 (192)	7.88 (200)	428.3
385S500-6	357	3	460	50 *	95.75 (2432)	45.67 (1160)	50.08 (1272)	7.56 (192)	7.88 (200)	451.2
385S500-7A	400	3	460	50 *	100.79 (2560)	45.67 (1160)	55.12 (1400)	7.56 (192)	7.88 (200)	461.1
385S600-7	416	3	460	60 *	105.12 (2670)	50.00 (1270)	55.12 (1400)	7.56 (192)	7.88 (200)	507.3
385S600-8	476	3	460	60 *	110.16 (2798)	50.00 (1270)	60.16 (1528)	7.56 (192)	7.88 (200)	517.2
385S750-9	536	3	460	75 *	118.35 (3006)	53.15 (1350)	65.2 (1656)	7.56 (192)	7.88 (200)	558.7
385S750-10	596	3	460	75 *	123.39 (3134)	53.15 (1350)	70.24 (1784)	7.56 (192)	7.88 (200)	568.6
385S1000-11	656	3	460	100 *	137.88 (3502)	62.60 (1590)	75.28 (1912)	7.56 (192)	7.88 (200)	677.5
385S1000-12	716	3	460	100 *	142.92 (3630)	62.60 (1590)	80.32 (2040)	7.56 (192)	7.88 (200)	687.4
385S1000-13	776	3	460	100 *	147.96 (3758)	62.60 (1590)	85.36 (2168)	7.56 (192)	7.88 (200)	697.3

Notes:

Control box is required for 3-wire, single-phase applications. Data does not include control box.

- MS402 motor.
- MS4000 motor.
- ▲ MS6 motor.
- △ MMS6000 motor.
- ★ MMS8000 motor.
- ◆ Takes MS6 motor; not available as complete.
- ☼ Takes MMS6000 motor; not available as complete.
- * Takes MMS8000 motor; not available as complete.
- † Takes MMS10000 motor; not available as complete.

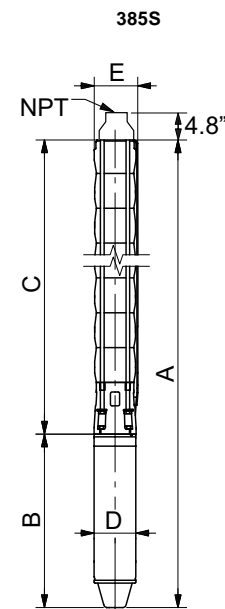

E = Maximum diameter of pump including cable guard and motor.

475S (475 gpm)

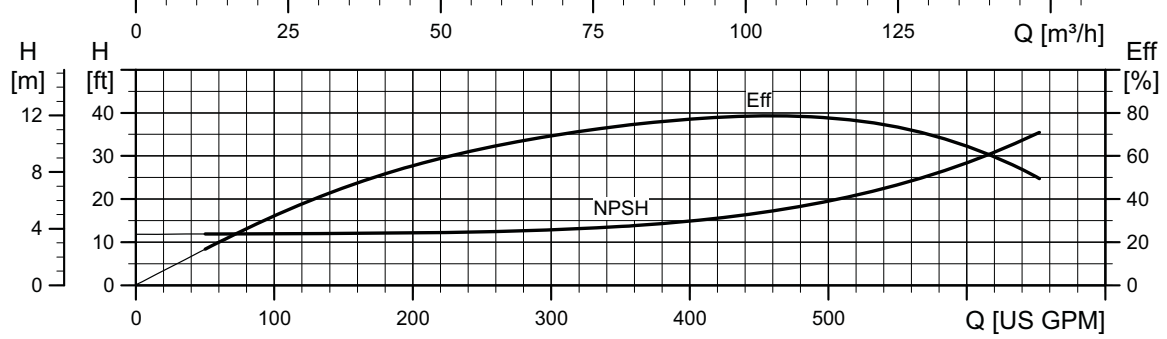
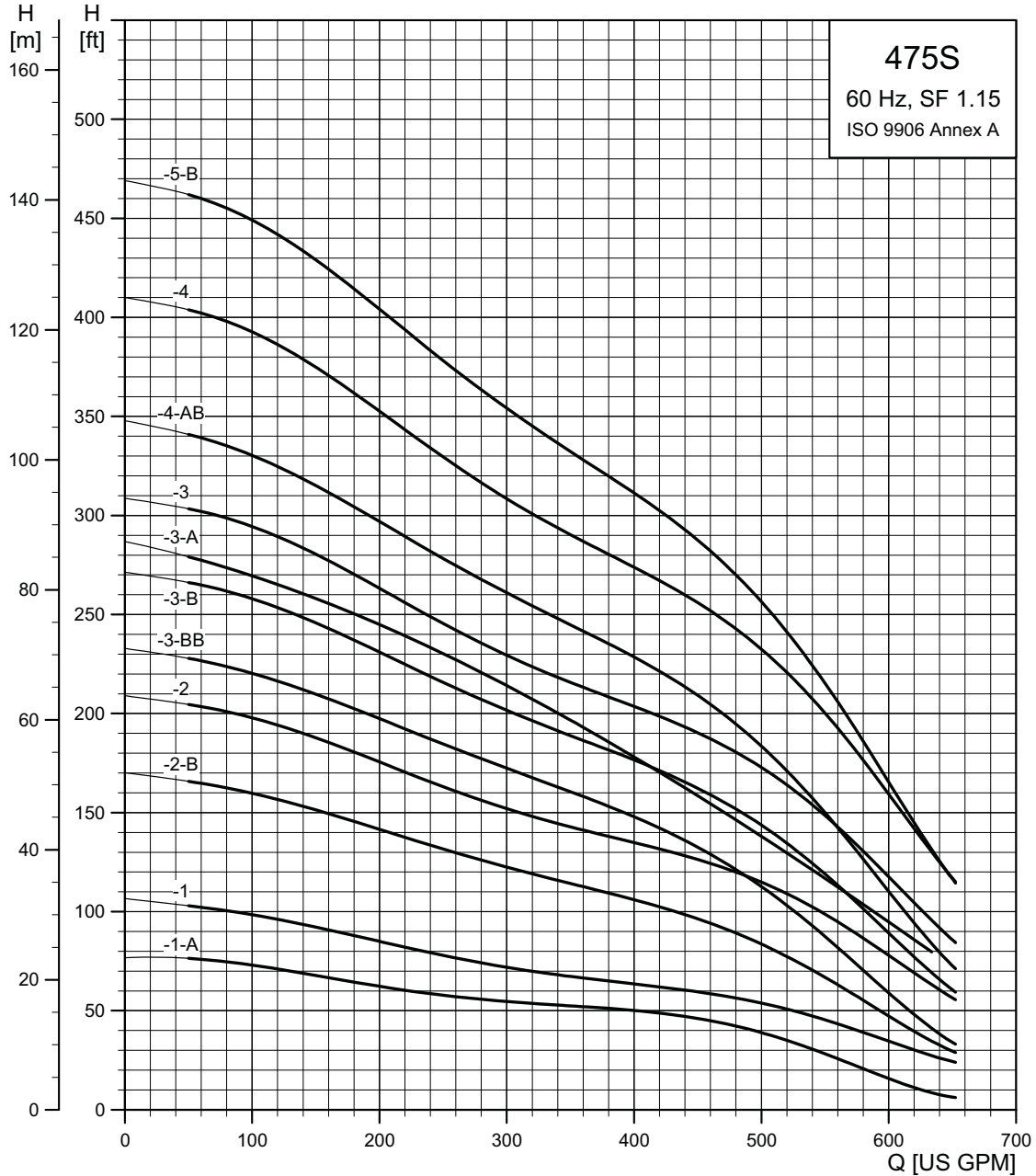

TM05 0255 0112

475S (475 gpm)

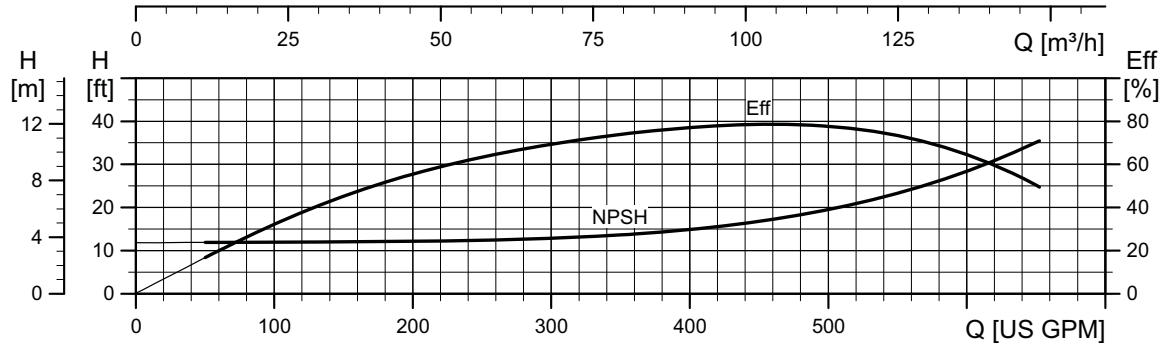
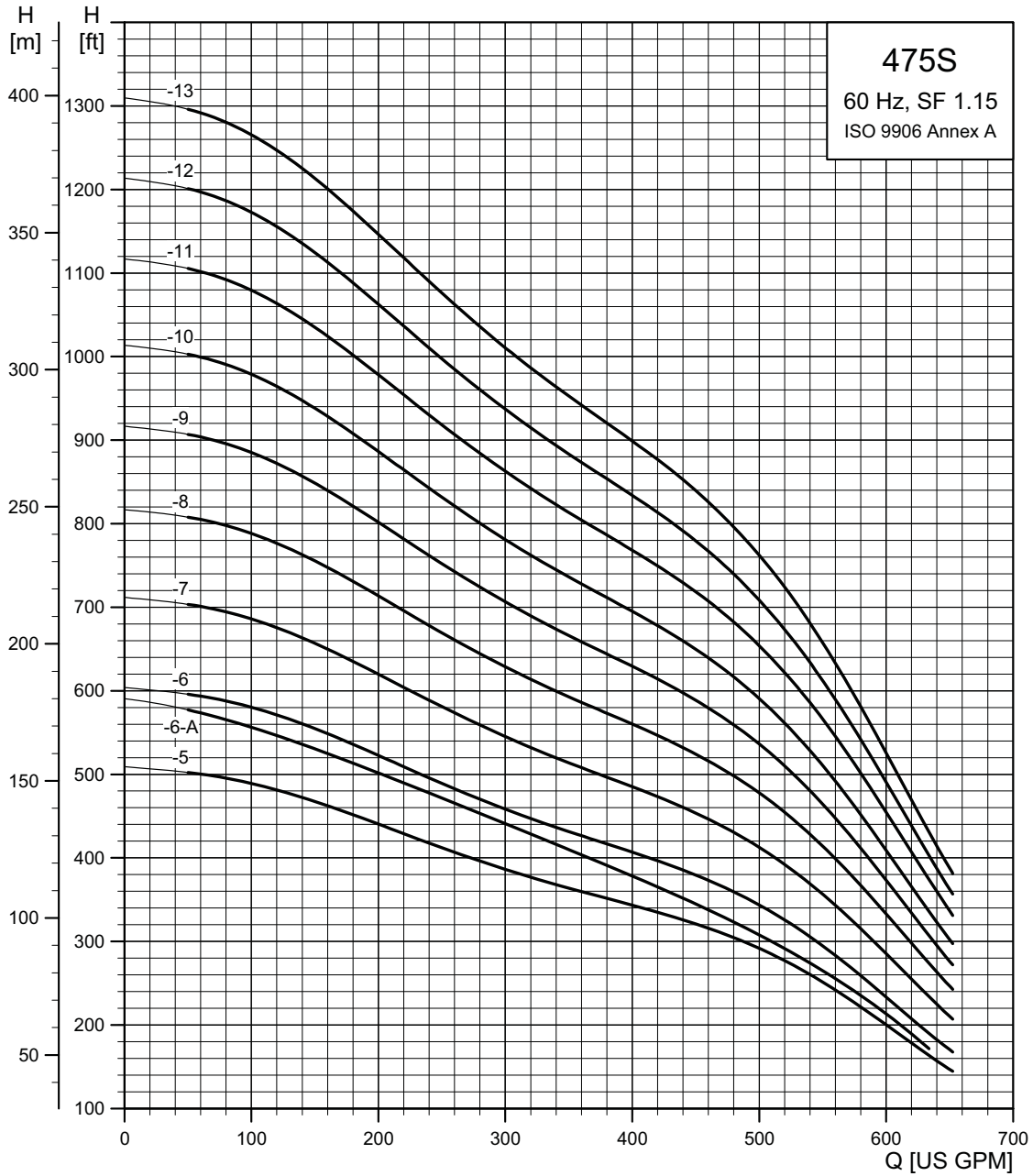

TM05 0256 0112

475S (475 gpm) pump power requirement (P2)

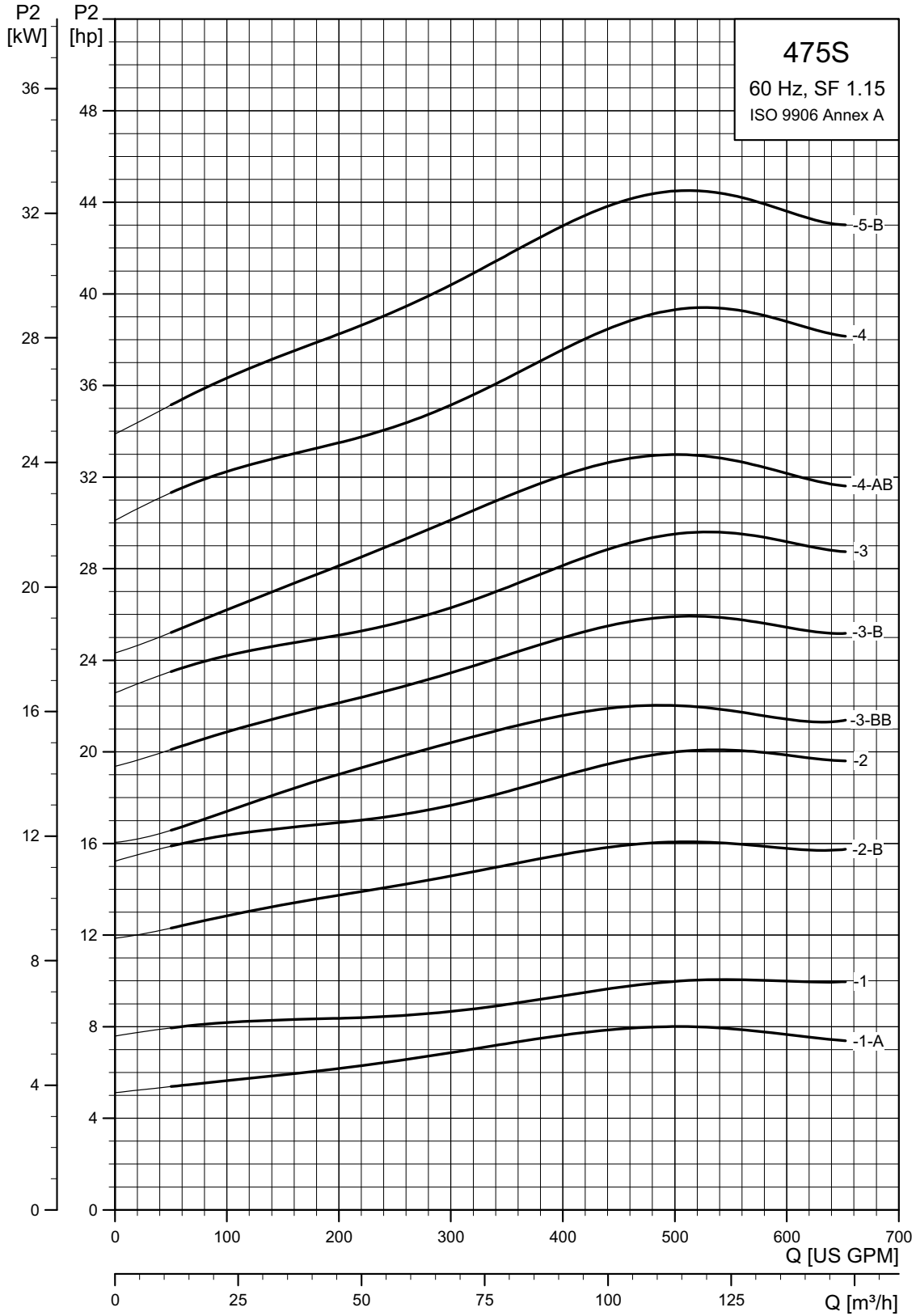

TM05 0257 0112

475S (475 gpm) pump power requirement (P2)

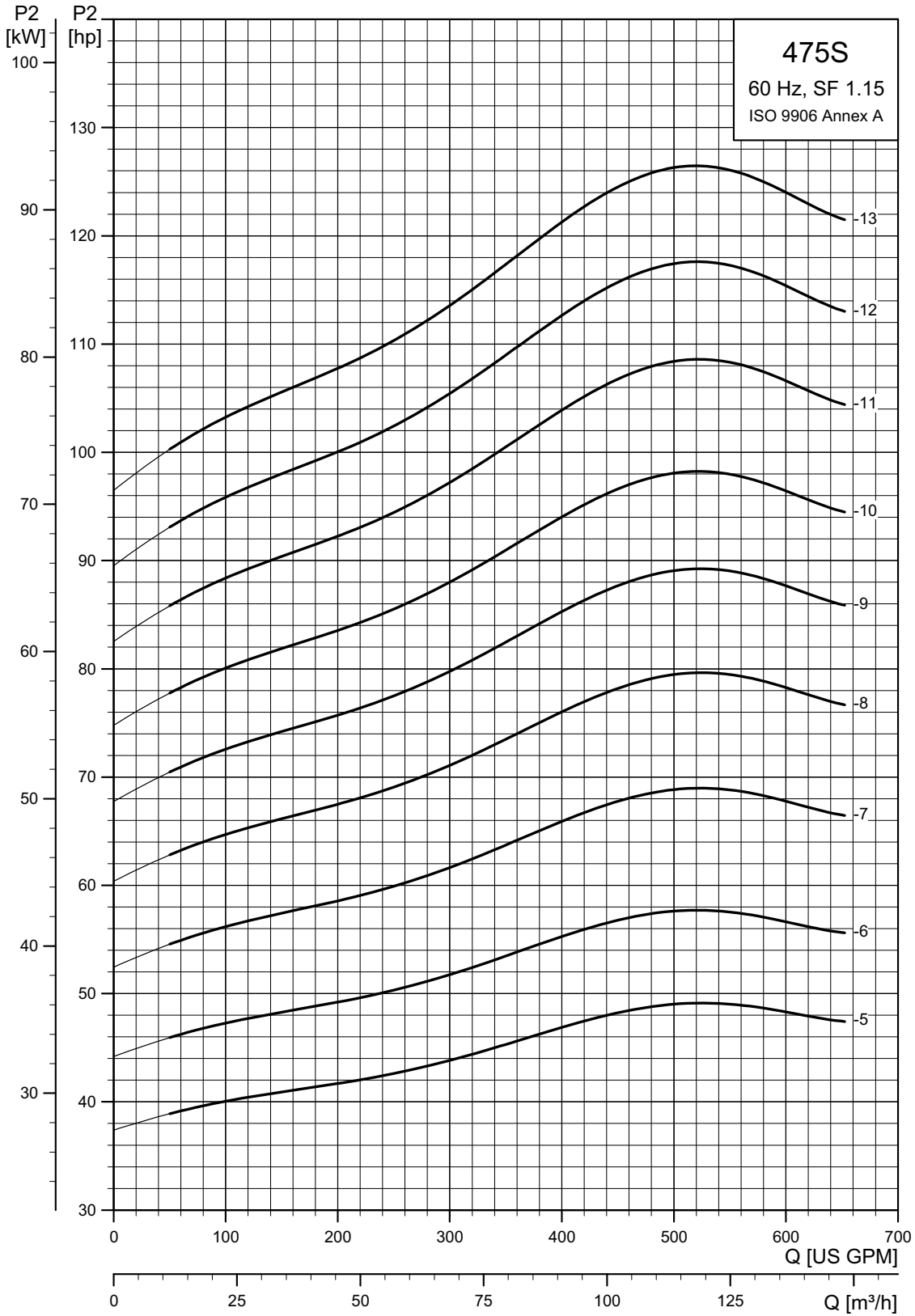

TM05 0258 0112

475S (475 gpm)

Pump model	Nom. head [ft]	Ph	Volts [V]	Motor [Hp]	Dimensions					Net weight (complete) [lb]	
					A [in (mm)]	B [in (mm)]	C [in (mm)]	D [in (mm)]	E [in (mm)]		
475S - Motor dia. 6 inch, 3 wire motor, 60 Hz, rated flow 475 gpm (5" NPT)											
475S75-1A	42	3	230	7.5	▲	46.58 (1183)	22.25 (565)	24.34 (618)	5.63 (143)	7.05 (179)	132.3
		3	460	7.5	▲	46.58 (1183)	22.25 (565)	24.34 (618)	5.63 (143)	7.05 (179)	132.3
475S100-1	58	3	230	10	▲	47.56 (1208)	23.23 (590)	24.34 (618)	5.63 (143)	7.05 (179)	132.3
		3	460	10	▲	47.56 (1208)	23.23 (590)	24.34 (618)	5.63 (143)	7.05 (179)	132.3
475S150-2B	89	3	230	15	▲	57.25 (1454)	27.88 (708)	29.38 (746)	5.63 (143)	7.05 (179)	170.1
		3	460	15	▲	57.25 (1454)	27.88 (708)	29.38 (746)	5.63 (143)	7.05 (179)	170.1
475S200-2	117	3	230	20	▲	60.20 (1529)	30.83 (783)	29.38 (746)	5.63 (143)	7.05 (179)	198.7
		3	460	20	▲	60.20 (1529)	30.83 (783)	29.38 (746)	5.63 (143)	7.05 (179)	198.7
475S250-3A	166	3	230	25	▲	67.41 (1712)	33.00 (838)	34.41 (874)	5.63 (143)	7.05 (179)	218.2
		3	460	25	▲	67.41 (1712)	33.00 (838)	34.41 (874)	5.63 (143)	7.05 (179)	218.2
475S300-3	177	3	230	30	▲	69.97 (1777)	35.56 (903)	34.41 (874)	5.63 (143)	7.05 (179)	233.6
		3	460	30	▲	69.97 (1777)	35.56 (903)	34.41 (874)	5.63 (143)	7.05 (179)	233.6
475S300-4AB	168	3	230	30	▲	75.00 (1905)	35.56 (903)	39.45 (1002)	5.63 (143)	7.05 (179)	239.9
		3	460	30	▲	75.00 (1905)	35.56 (903)	39.45 (1002)	5.63 (143)	7.05 (179)	239.9
475S400-4	236	3	460	40	▲	79.73 (2025)	40.28 (1023)	39.45 (1002)	5.63 (143)	7.05 (179)	268.5
475S - Motor dia. 6 inch, 3 wire motor, 60 Hz, rated flow 475 gpm (6" NPT)											
475S400-5B	268	3	460	40	▲	84.77 (2153)	40.28 (1023)	44.49 (1130)	5.63 (143)	7.05 (179)	356.0
475S500-5	296	3	460	50	☼	100.6 (2555)	56.11 (1425)	44.49 (1130)	5.67 (144)	7.05 (179)	384.0
475S500-6A	344	3	460	50	☼	105.63 (2683)	56.11 (1425)	49.53 (1258)	5.67 (144)	7.05 (179)	385.0
475S600-6	355	3	460	60	◆	—	—	50.08 (1272)	—	7.05 (179)	—
475S600-7	415	3	460	60	◆	—	—	55.12 (1400)	—	7.05 (179)	—
475S - Motor dia. 8 inch, 3 wire motor, 60 Hz, rated flow 475 gpm (6" NPT)											
475S400-4	236	3	460	40	*	83.71 (2126)	43.71 (1110)	40.00 (1016)	7.56 (192)	8.08 (205)	406.5
475S400-5B	268	3	460	40	*	88.75 (2254)	43.71 (1110)	45.04 (1144)	7.56 (192)	8.08 (205)	—
475S500-5	296	3	460	50	*	90.71 (2304)	45.67 (1160)	45.04 (1144)	7.56 (192)	8.08 (205)	420.4
475S500-6A	344	3	460	50	*	95.75 (2432)	45.67 (1160)	50.08 (1272)	7.56 (192)	8.08 (205)	—
475S600-6	355	3	460	60	*	100.08 (2542)	50.00 (1270)	50.08 (1272)	7.56 (192)	8.08 (205)	476.0
475S600-7	415	3	460	60	*	105.12 (2670)	50.00 (1270)	55.12 (1400)	7.56 (192)	8.08 (205)	482.6
475S750-8	534	3	460	75	*	113.31 (2878)	53.15 (1350)	60.16 (1528)	7.56 (192)	8.08 (205)	524.4
475S1000-9	534	3	460	100	*	127.8 (3246)	62.60 (1590)	65.20 (1656)	7.56 (192)	8.08 (205)	631.0
475S1000-10	593	3	460	100	*	132.84 (3374)	62.60 (1590)	70.24 (1784)	7.56 (192)	8.08 (205)	637.6
475S1000-11	653	3	460	100	*	137.88 (3502)	62.60 (1590)	75.28 (1912)	7.56 (192)	8.08 (205)	644.3
475S1250-12	712	3	460	125	*	152.37 (3870)	72.05 (1830)	80.32 (2040)	7.56 (192)	8.08 (205)	754.1
475S1250-13	772	3	460	125	*	157.41 (3998)	72.05 (1830)	85.36 (2168)	7.56 (192)	8.08 (205)	760.7

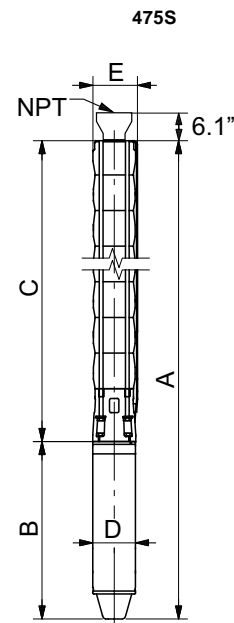

E = Maximum diameter of pump including cable guard and motor.

TM05 2531 0212

Notes:

Control box is required for 3-wire, single-phase applications. Data does not include control box.

- MS402 motor.
- MS4000 motor.
- ▲ MS6 motor.
- △ MMS6000 motor.
- ★ MMS8000 motor.
- ◆ Takes MS6 motor; not available as complete.
- ☼ Takes MMS6000 motor; not available as complete.
- * Takes MMS8000 motor; not available as complete.
- † Takes MMS10000 motor; not available as complete.

625S (625 gpm)

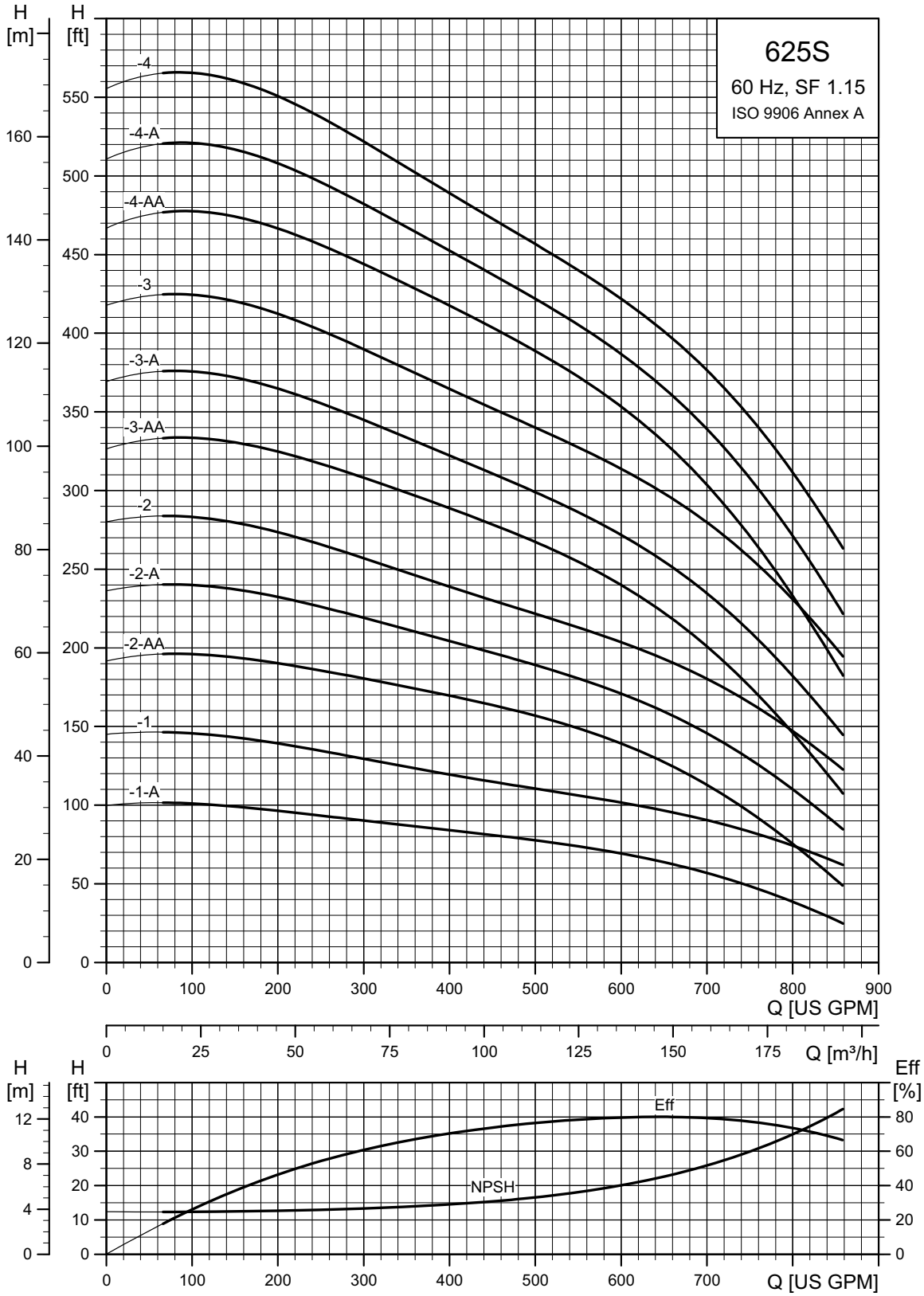

TM05 0259 0112

625S (625 gpm)

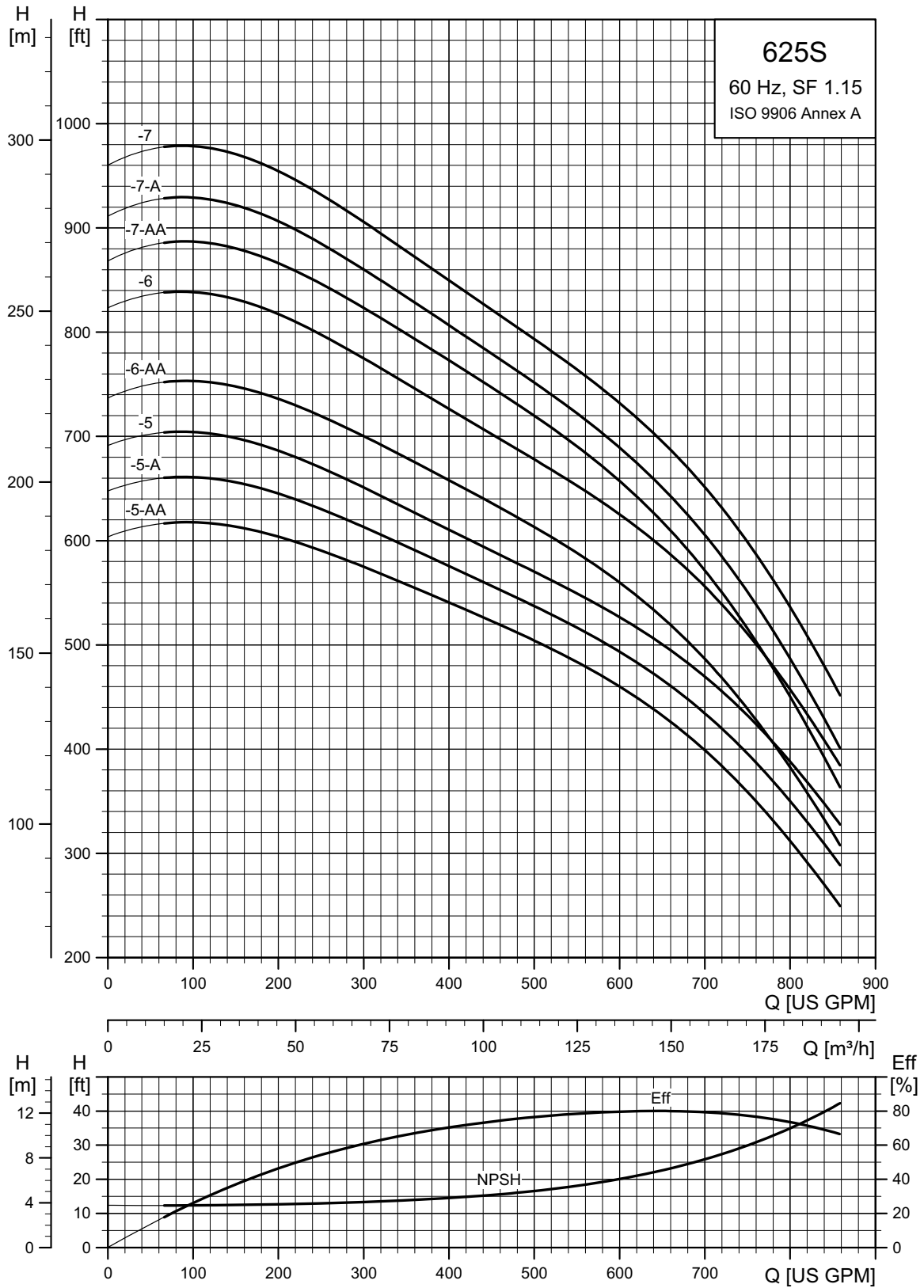

TM05 0260 0112

625S (625 gpm) pump power requirement (P2)

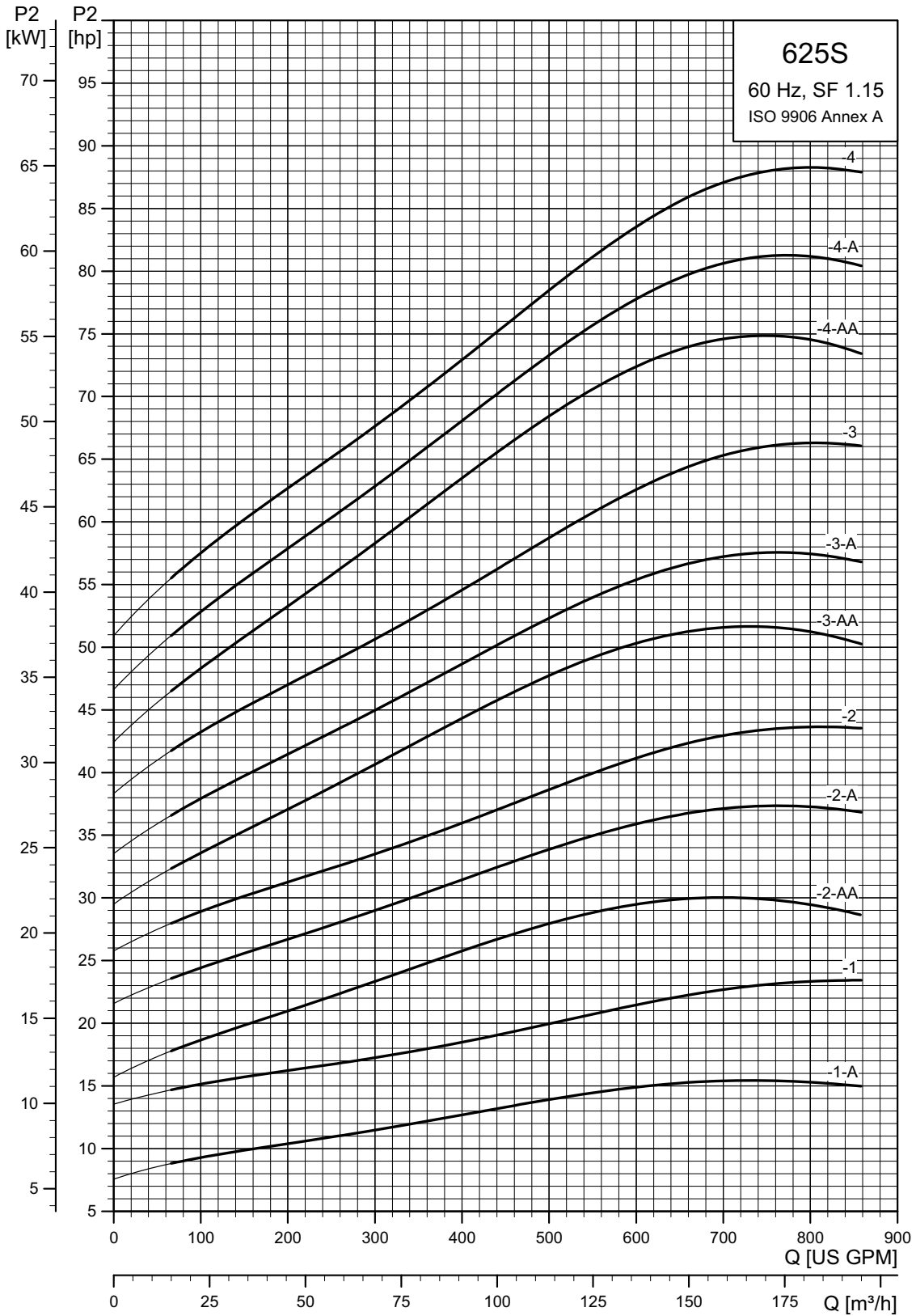

TM05 0261 0112

625S (625 gpm) pump power requirement (P2)

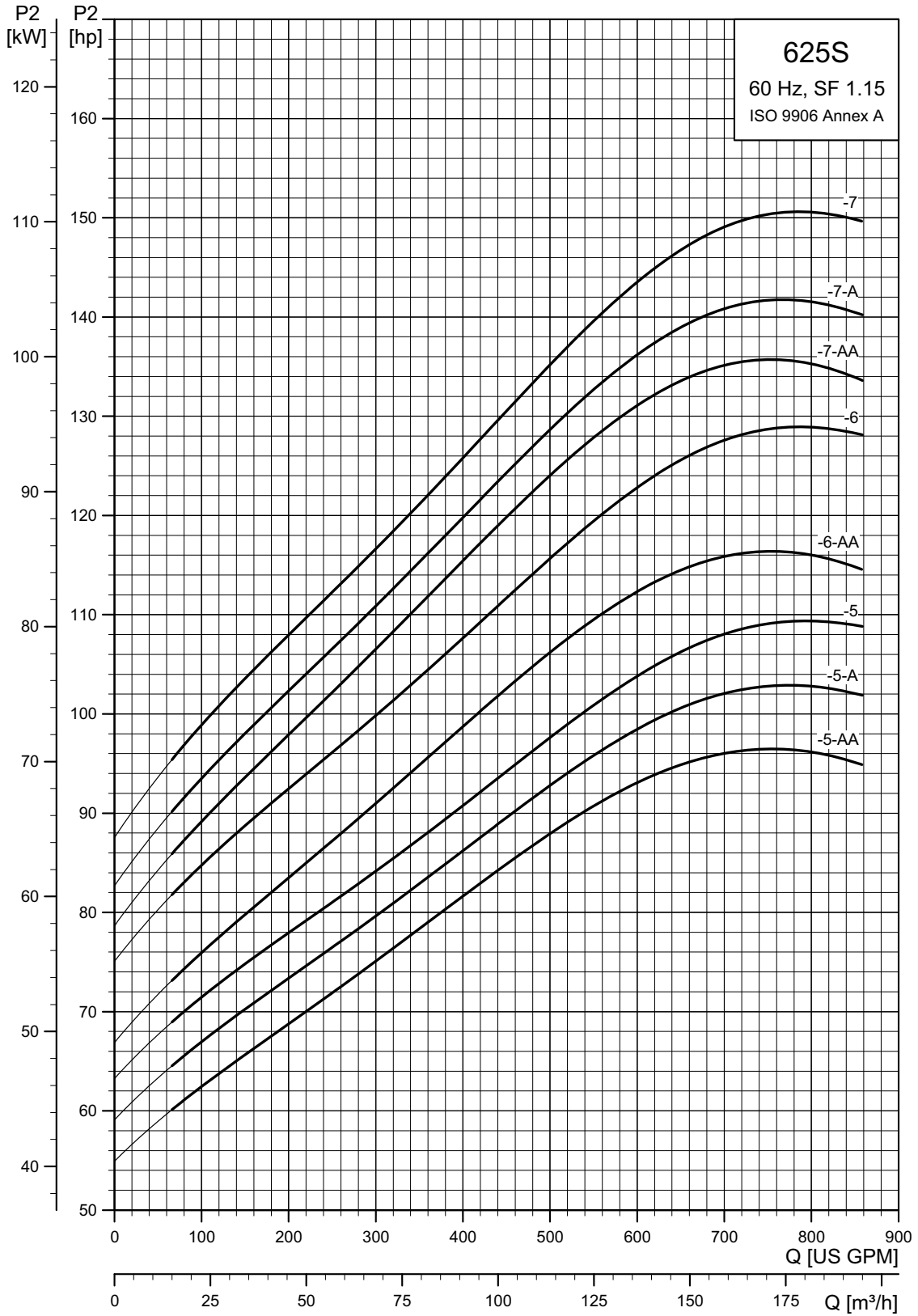

TM05 0262 0112

625S (625 gpm)

Pump model	Nom. head [ft]	Ph	Volts [V]	Motor [Hp]	Dimensions					Net weight (complete) [lb]	
					A [in (mm)]	B [in (mm)]	C [in (mm)]	D [in (mm)]	E [in (mm)]		
625S - Motor dia. 6 inch, 3 wire motor, 60 Hz, rated flow 625 gpm (6" NPT)											
625S150-1A	65	3	230	15	▲	53.51 (1359)	27.88 (708)	25.63 (651)	5.63 (143)	8.31 (211)	193.0
		3	460	15	▲	53.51 (1359)	27.88 (708)	25.63 (651)	5.63 (143)	8.31 (211)	193.0
625S250-1	95	3	230	25	▲	58.63 (1489)	33.00 (838)	25.63 (651)	5.63 (143)	8.31 (211)	189.9
		3	460	25	▲	58.63 (1489)	33.00 (838)	25.63 (651)	5.63 (143)	8.31 (211)	198.9
625S300-2AA	130	3	230	30	▲	67.33 (1710)	35.56 (903)	31.78 (807)	5.63 (143)	8.31 (211)	213.0
		3	460	30	▲	67.33 (1710)	35.56 (903)	31.78 (807)	5.63 (143)	8.31 (211)	222.3
625S400-2A	159	3	460	40	▲	72.05 (1830)	40.28 (1023)	31.78 (807)	5.63 (143)	8.31 (211)	333.8
625S400-2	194	3	460	40	▲	72.05 (1830)	40.28 (1023)	31.78 (807)	5.63 (143)	8.31 (211)	333.8
625S500-3AA	224	3	460	50	◆	94.02 (2388)	56.11 (1425)	37.94 (963)	5.63 (143)	8.31 (211)	376.4
625S600-3A	258	3	460	60	◆	—	—	37.92 (963)	—	8.31 (211)	—
625S600-3	292	3	460	60	◆	—	—	37.92 (963)	—	8.31 (211)	—
625S - Motor dia. 8 inch, 3 wire motor, 60 Hz, rated flow 625 gpm (6" NPT)											
625S400-2	194	3	460	40	*	76.03 (1931)	43.71 (1110)	32.33 (821)	7.56 (192)	8.39 (213)	409.4
625S500-3AA	224	3	460	50	*	83.59 (2123)	45.67 (1160)	37.92 (963)	7.56 (192)	8.39 (213)	444.6
625S600-3A	258	3	460	60	*	87.92 (2233)	50.00 (1270)	37.92 (963)	7.56 (192)	8.39 (213)	490.8
625S600-3	292	3	460	60	*	87.92 (2233)	50.00 (1270)	37.92 (963)	7.56 (192)	8.39 (213)	490.8
625S750-4AA	322	3	460	75	*	97.21 (2469)	53.15 (1350)	44.06 (1119)	7.56 (192)	8.39 (213)	534.8
625S750-4A	357	3	460	75	*	97.21 (2469)	53.15 (1350)	44.06 (1119)	7.56 (192)	8.39 (213)	534.8
625S1000-4	391	3	460	100	*	106.66 (2709)	62.60 (1590)	44.06 (1119)	7.56 (192)	8.39 (213)	633.8
625S1000-5AA	421	3	460	100	*	112.76 (2864)	62.60 (1590)	50.16 (1274)	7.56 (192)	8.39 (213)	649.3
625S1000-5A	455	3	460	100	*	112.76 (2864)	62.60 (1590)	50.16 (1274)	7.56 (192)	8.39 (213)	649.3
625S1000-5	490	3	460	100	*	112.76 (2864)	62.60 (1590)	50.16 (1274)	7.56 (192)	8.39 (213)	649.3
625S1250-6AA	520	3	460	125	*	128.31 (3259)	72.05 (1830)	56.26 (1429)	7.56 (192)	8.39 (213)	761.5
625S1250-6	554	3	460	125	*	128.31 (3259)	72.05 (1830)	56.26 (1429)	7.56 (192)	8.39 (213)	761.5
625S1250-7AA	618	3	460	125	*	134.45 (3415)	72.05 (1830)	62.41 (1585)	7.56 (192)	8.39 (213)	774.7
625S1500-7A	653	3	460	150	*	143.51 (3645)	81.11 (2060)	62.41 (1585)	7.56 (192)	8.39 (213)	884.7
625S1500-7	687	3	460	150	*	143.51 (3645)	81.11 (2060)	62.41 (1585)	7.56 (192)	8.39 (213)	884.7

Notes:

Control box is required for 3-wire, single-phase applications. Data does not include control box.

- MS402 motor.
- MS4000 motor.
- ▲ MS6 motor.
- △ MMS6000 motor.
- ★ MMS8000 motor.
- ◆ Takes MS6 motor; not available as complete.
- ☆ Takes MMS6000 motor; not available as complete.
- * Takes MMS8000 motor; not available as complete.
- † Takes MMS10000 motor; not available as complete.

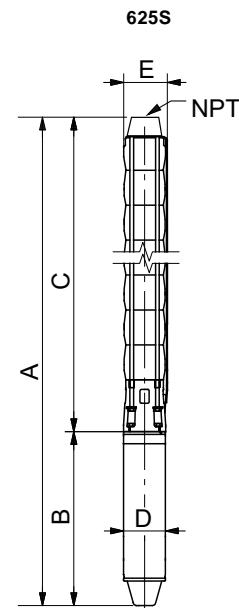

E = Maximum diameter of pump including cable guard and motor.

TM05 25310212

800S (800 gpm)

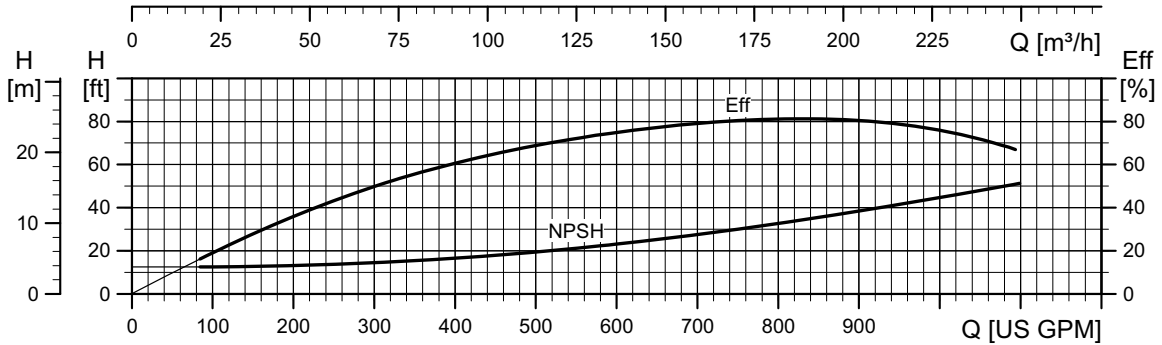
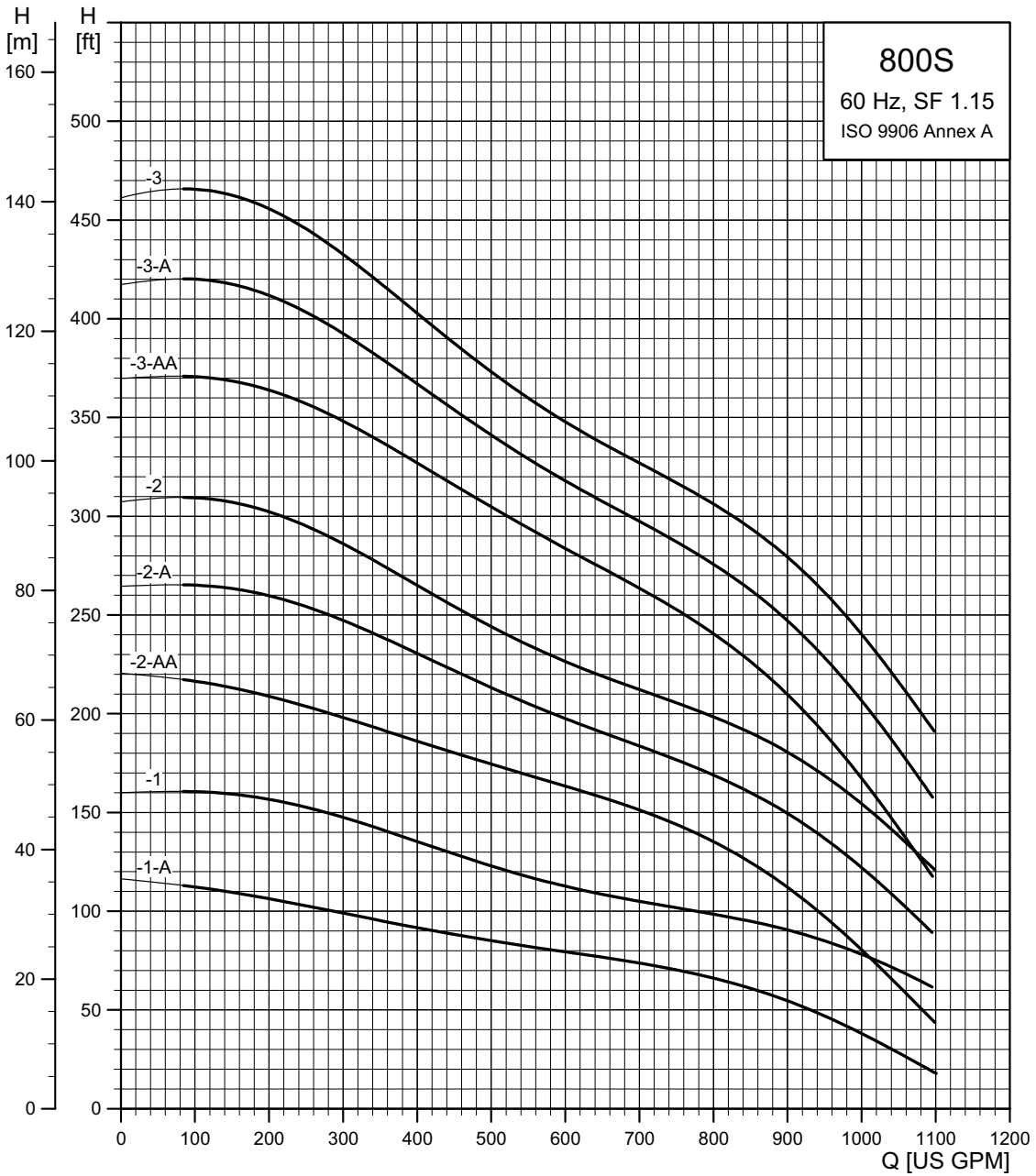

TN05 0263 0112

800S (800 gpm)

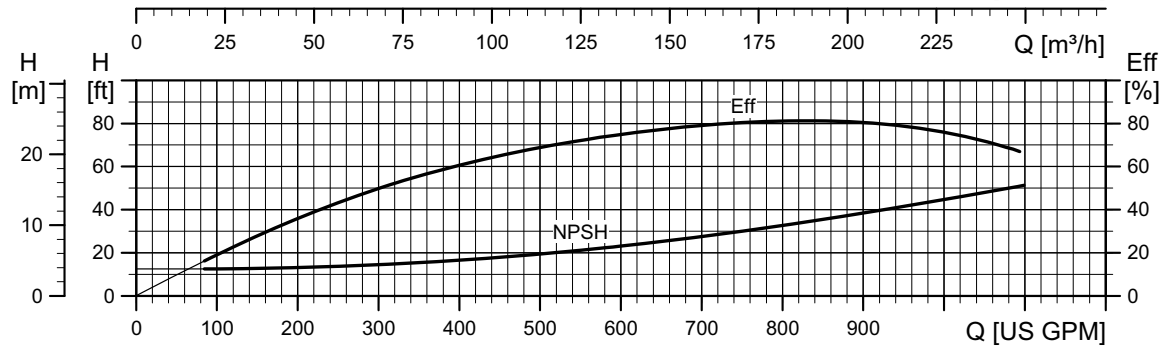
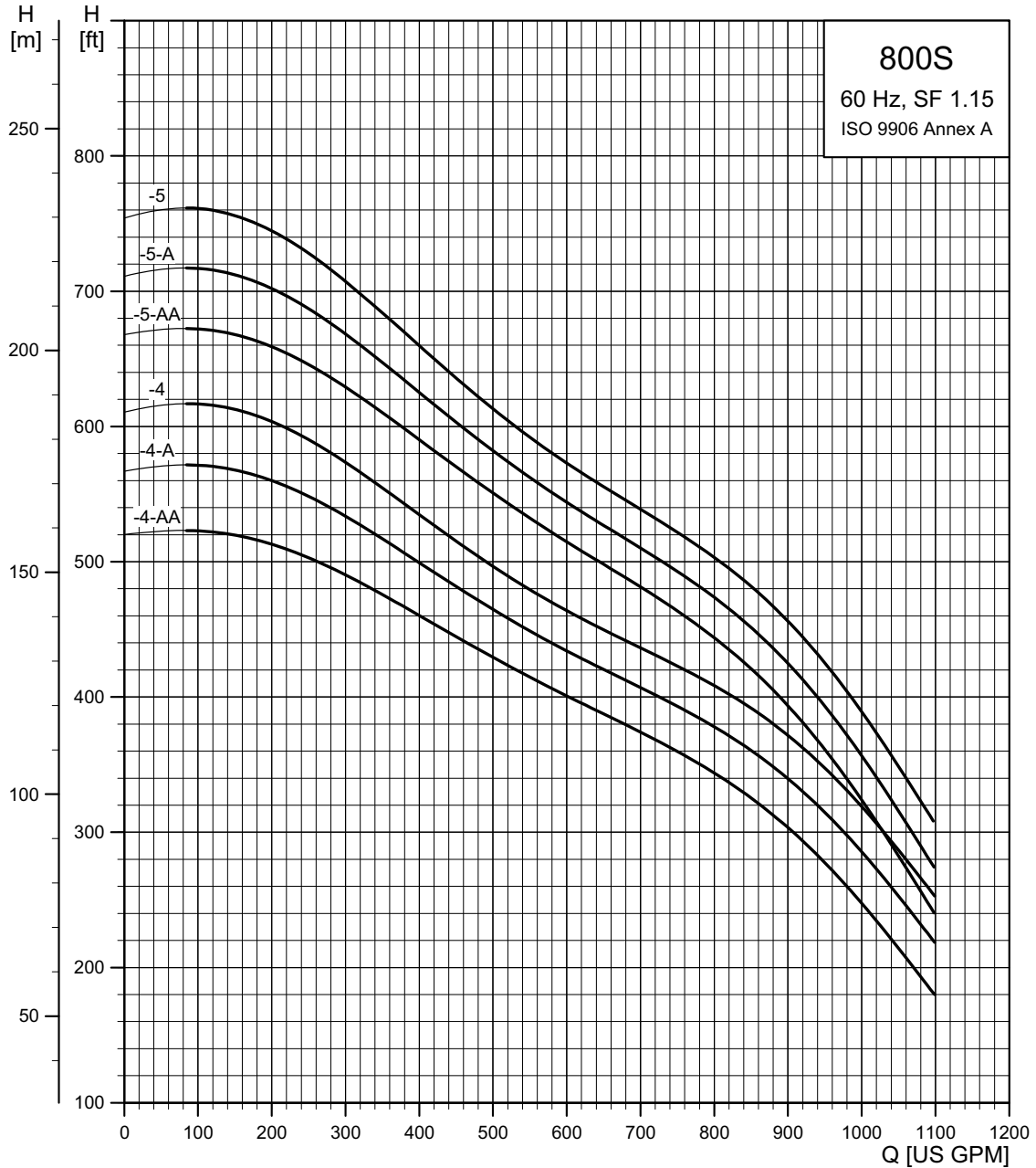

TM05 0264 0112

800S (800 gpm) pump power requirement (P2)

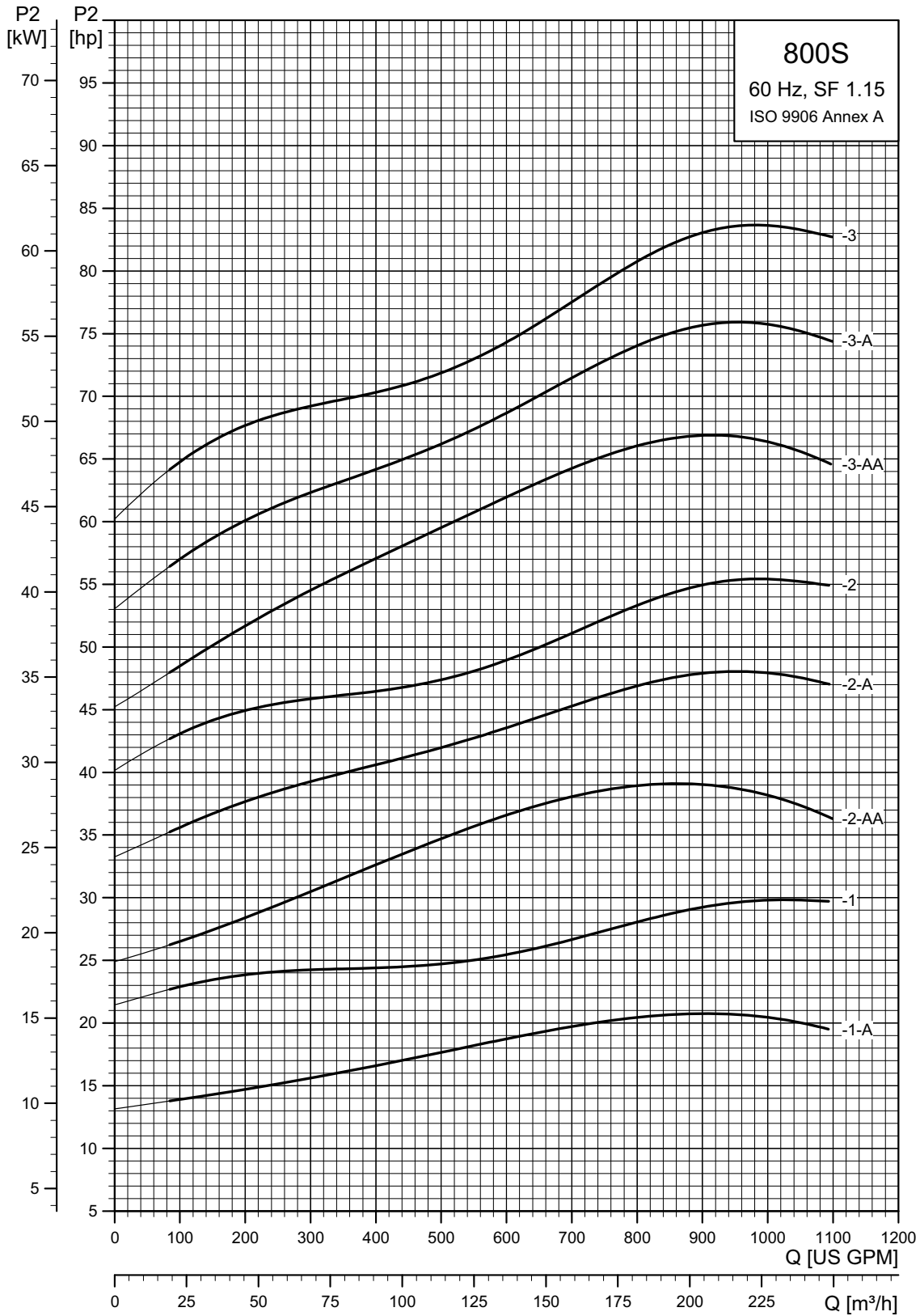

TM05 0265 0112

800S (800 gpm) pump power requirement (P2)

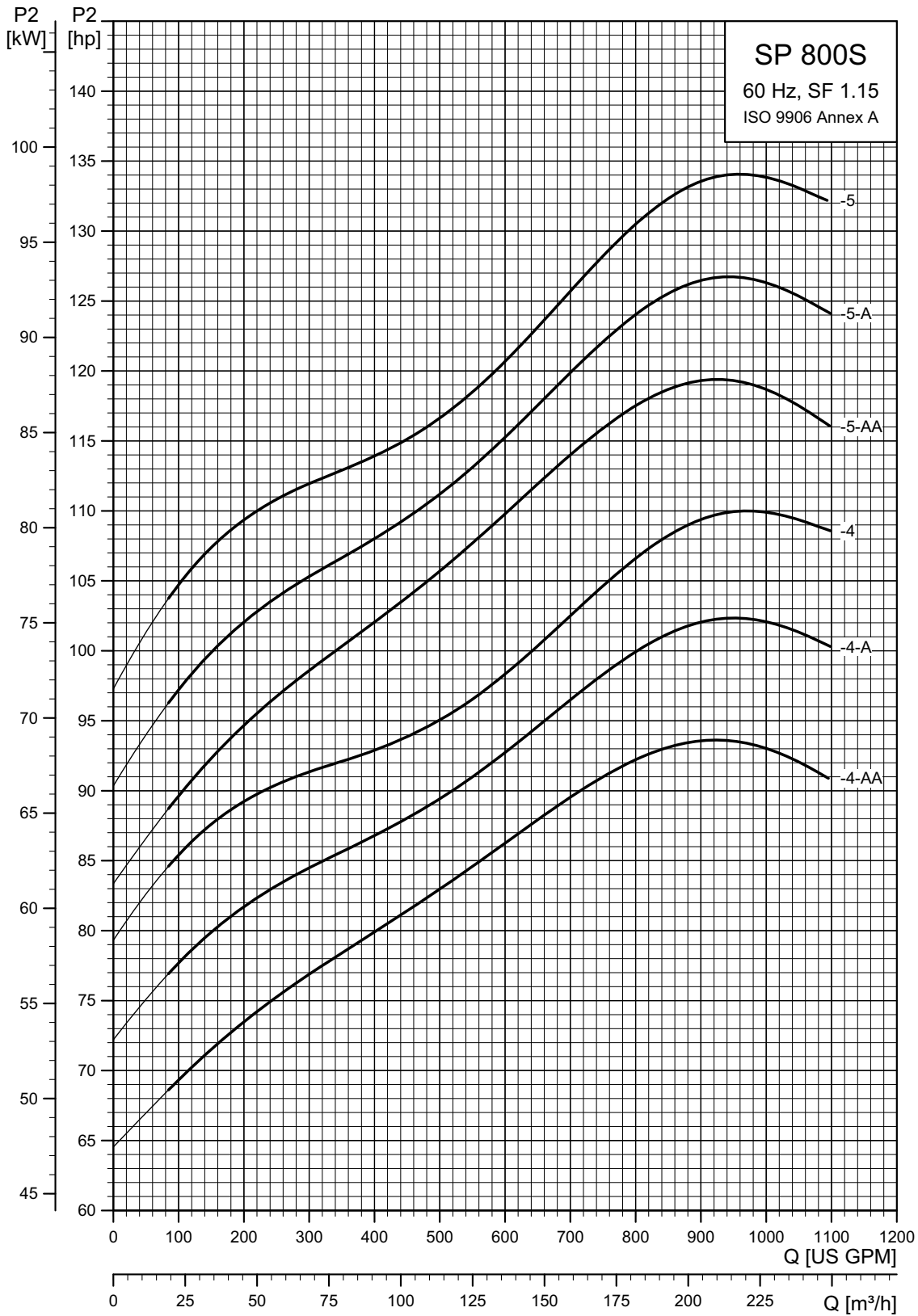

TM05 0266 0811

800S (800 gpm)

Pump model	Nom. head [ft]	Ph	Volts [V]	Motor [Hp]	Dimensions					Net weight (complete) [lb]	
					A [in (mm)]	B [in (mm)]	C [in (mm)]	D [in (mm)]	E [in (mm)]		
800S - Motor dia. 6 inch, 3 wire motor, 60 Hz, rated flow 800 gpm (6" NPT)											
800S200-1A	64	3	230	20	▲	56.50 (1435)	30.83 (783)	25.67 (652)	5.63 (143)	8.31 (211)	180.0
		3	460	20	▲	56.50 (1435)	30.83 (783)	25.67 (652)	5.63 (143)	8.31 (211)	180.0
800S300-1	96	3	230	30	▲	61.23 (1555)	35.56 (903)	25.67 (652)	5.63 (143)	8.31 (211)	202.5
		3	460	30	▲	61.23 (1555)	35.56 (903)	25.67 (652)	5.63 (143)	8.31 (211)	202.5
800S400-2AA	131	3	460	35	▲	72.05 (1830)	40.28 (1023)	31.78 (807)	5.63 (143)	8.31 (211)	257.4
800S500-2A	162	3	460	50	☼	88.00 (2235)	56.11 (1425)	31.87 (810)	7.56 (192)	8.39 (213)	363.2
800S500-2	194	3	460	50	☼	88.00 (2235)	56.11 (1425)	31.87 (810)	7.56 (192)	8.39 (213)	363.2
800S600-3AA	197	3	460	60	◆	—	—	37.92 (963)	—	8.39 (213)	—
800S - Motor dia. 8 inch, 3 wire motor, 60 Hz, rated flow 800 gpm (6" NPT)											
800S400-2AA	131	3	460	40	*	75.48 (1917)	43.71 (1110)	31.78 (807)	7.56 (192)	8.39 (213)	409.4
800S500-2A	162	3	460	50	*	77.45 (1967)	45.67 (1160)	31.78 (807)	7.56 (192)	8.39 (213)	431.4
800S500-2	187	3	460	50	*	77.45 (1967)	45.67 (1160)	31.78 (807)	7.56 (192)	8.39 (213)	438.0
800S600-3AA	229	3	460	60	*	87.92 (2233)	50.00 (1270)	37.92 (963)	7.56 (192)	8.39 (213)	490.8
800S750-3A	260	3	460	75	*	91.07 (2313)	53.15 (1350)	37.92 (963)	7.56 (192)	8.39 (213)	523.8
800S750-3	292	3	460	75	*	91.07 (2313)	53.15 (1350)	37.92 (963)	7.56 (192)	8.39 (213)	523.8
800S1000-4AA	327	3	460	100	*	106.62 (2708)	62.60 (1590)	44.02 (1118)	7.56 (192)	8.39 (213)	633.8
800S1000-4A	358	3	460	100	*	106.62 (2708)	62.60 (1590)	44.02 (1118)	7.56 (192)	8.39 (213)	633.8
800S1000-4	389	3	460	100	*	106.62 (2708)	62.60 (1590)	44.02 (1118)	7.56 (192)	8.39 (213)	633.8
800S1250-5AA	426	3	460	125	*	122.21 (3104)	72.05 (1830)	50.16 (1274)	7.56 (192)	8.39 (213)	748.3
800S1250-5A	456	3	460	125	*	122.21 (3104)	72.05 (1830)	50.16 (1274)	7.56 (192)	8.39 (213)	748.3
800S1250-5	487	3	460	125	*	122.21 (3104)	72.05 (1830)	50.16 (1274)	7.56 (192)	8.39 (213)	746.6

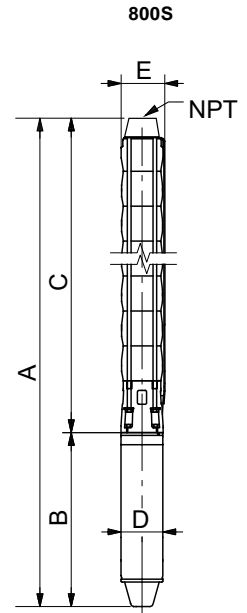

E = Maximum diameter of pump including cable guard and motor.

TM05 5 2532 0212

Notes:

Control box is required for 3-wire, single-phase applications. Data does not include control box.

- MS402 motor.
- MS4000 motor.
- ▲ MS6 motor.
- △ MMS6000 motor.
- ★ MMS8000 motor.
- ◆ Takes MS6 motor; not available as complete.
- ☼ Takes MMS6000 motor; not available as complete.
- * Takes MMS8000 motor; not available as complete.
- † Takes MMS10000 motor; not available as complete.

1100S (1100 gpm)

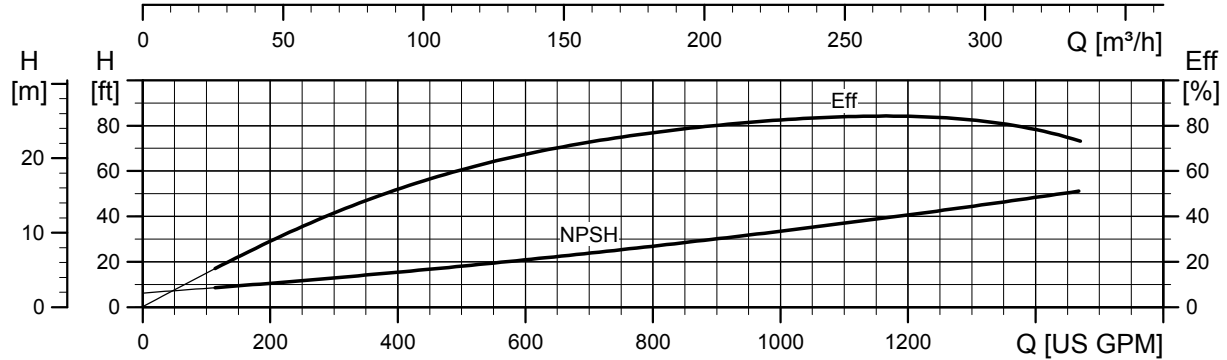
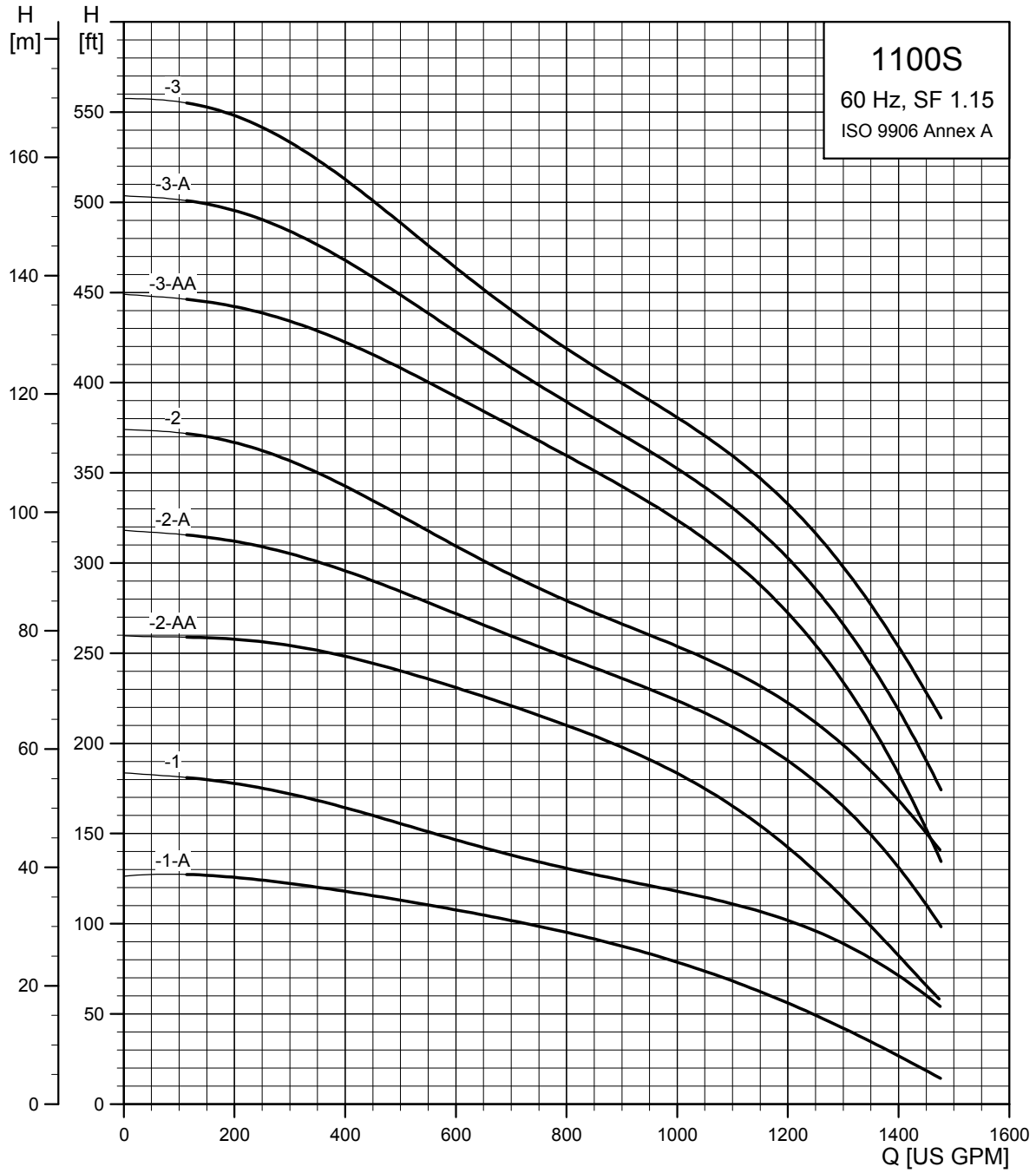

TM05 0267 4611

1100S (1100 gpm)

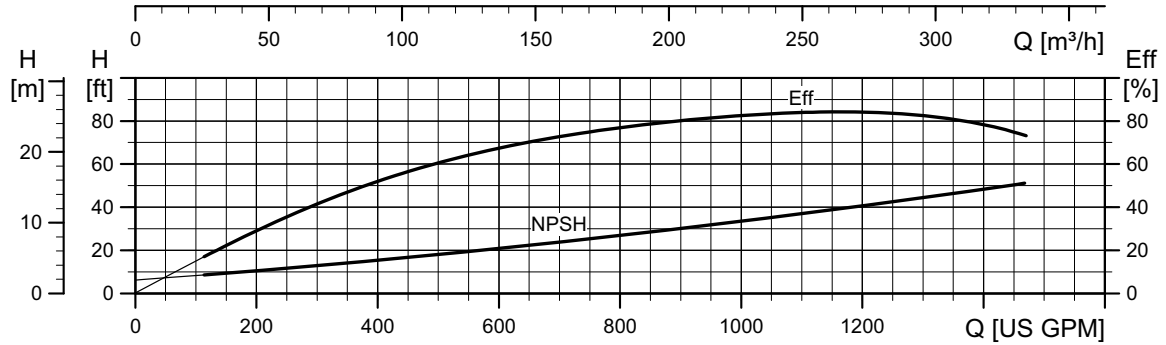
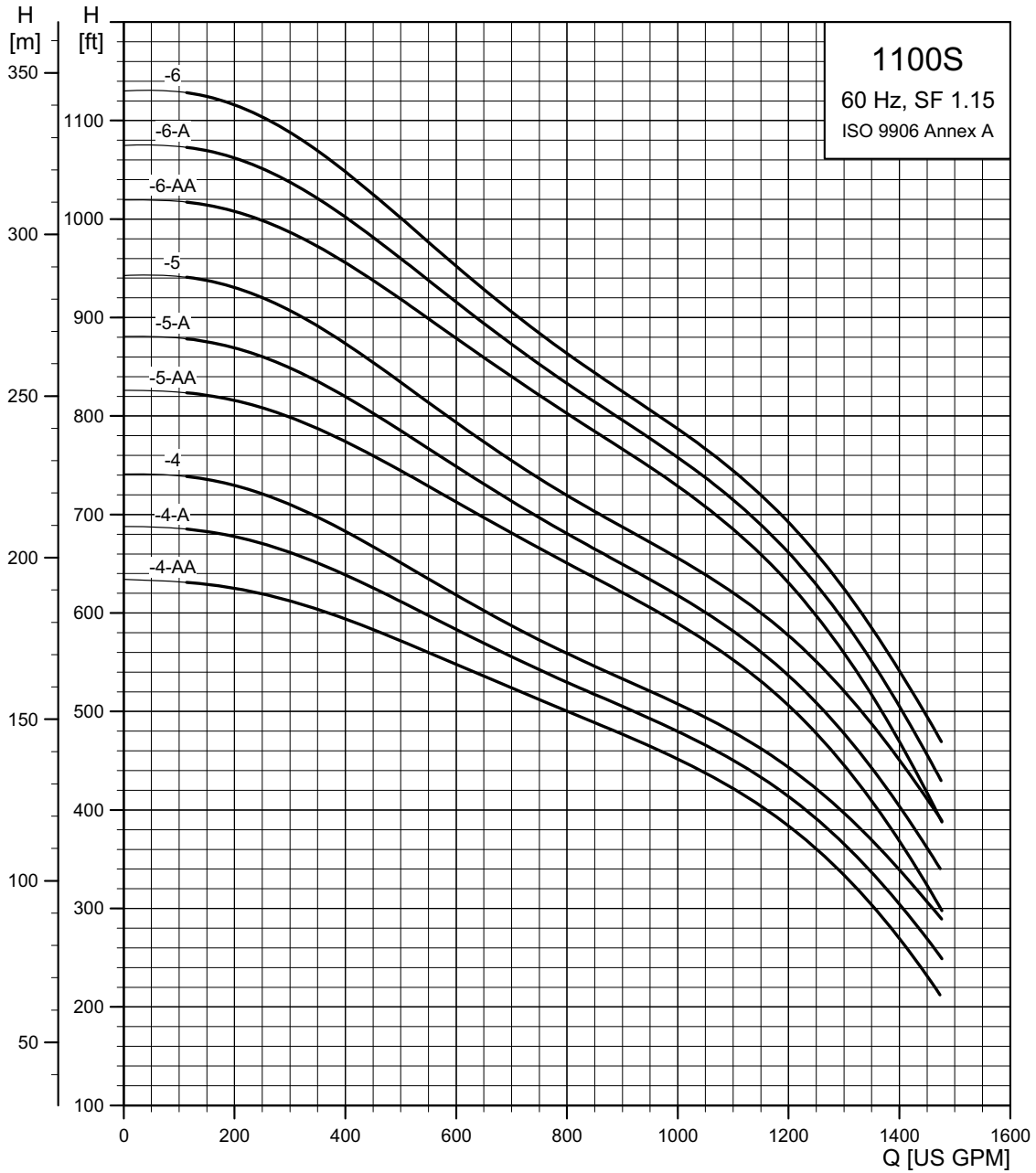

TM05 0268 0 112

1100S (1100 gpm) pump power requirement (P2)

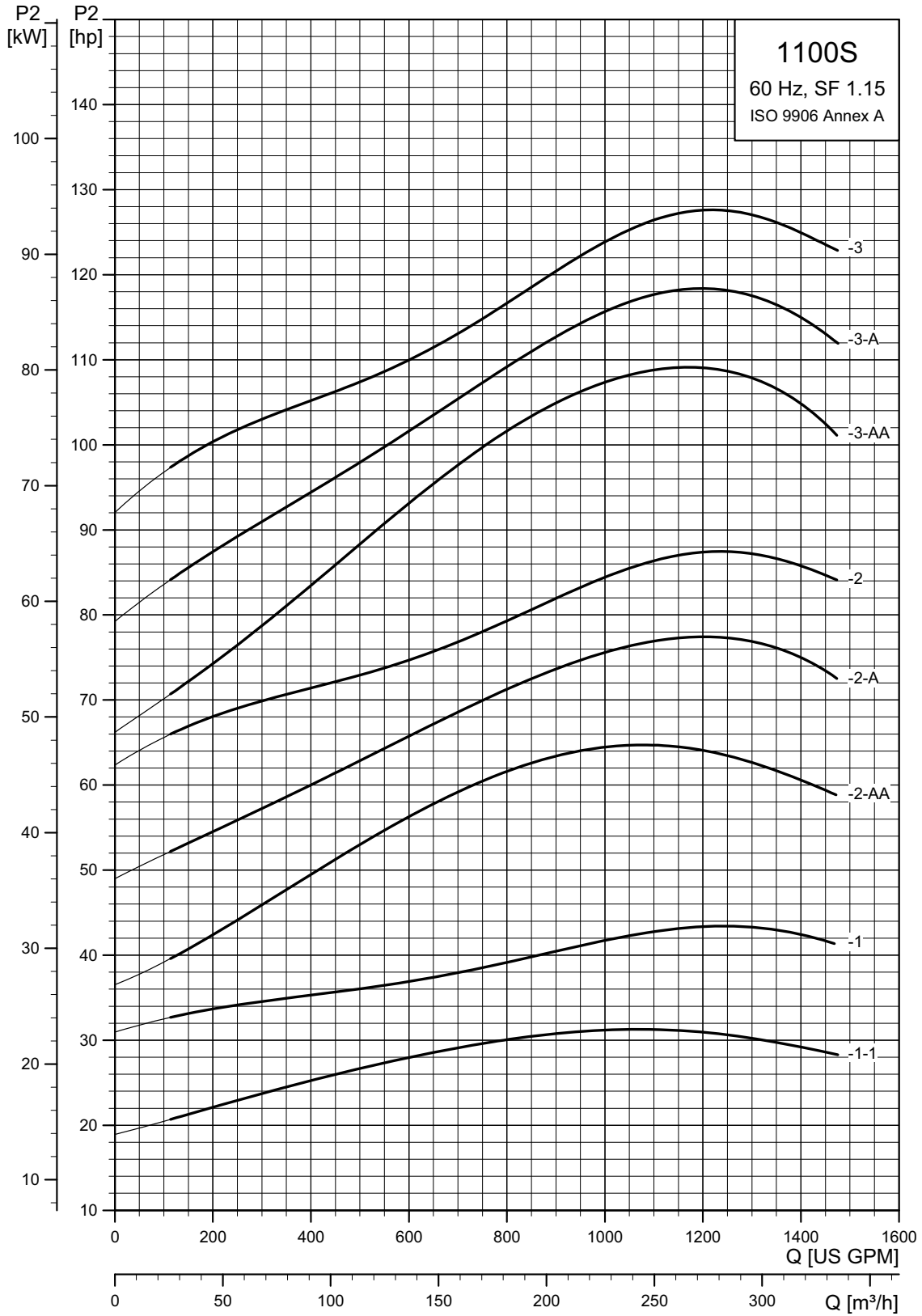

TM05 0269 0112

1100S (1100 gpm) pump power requirement (P2)

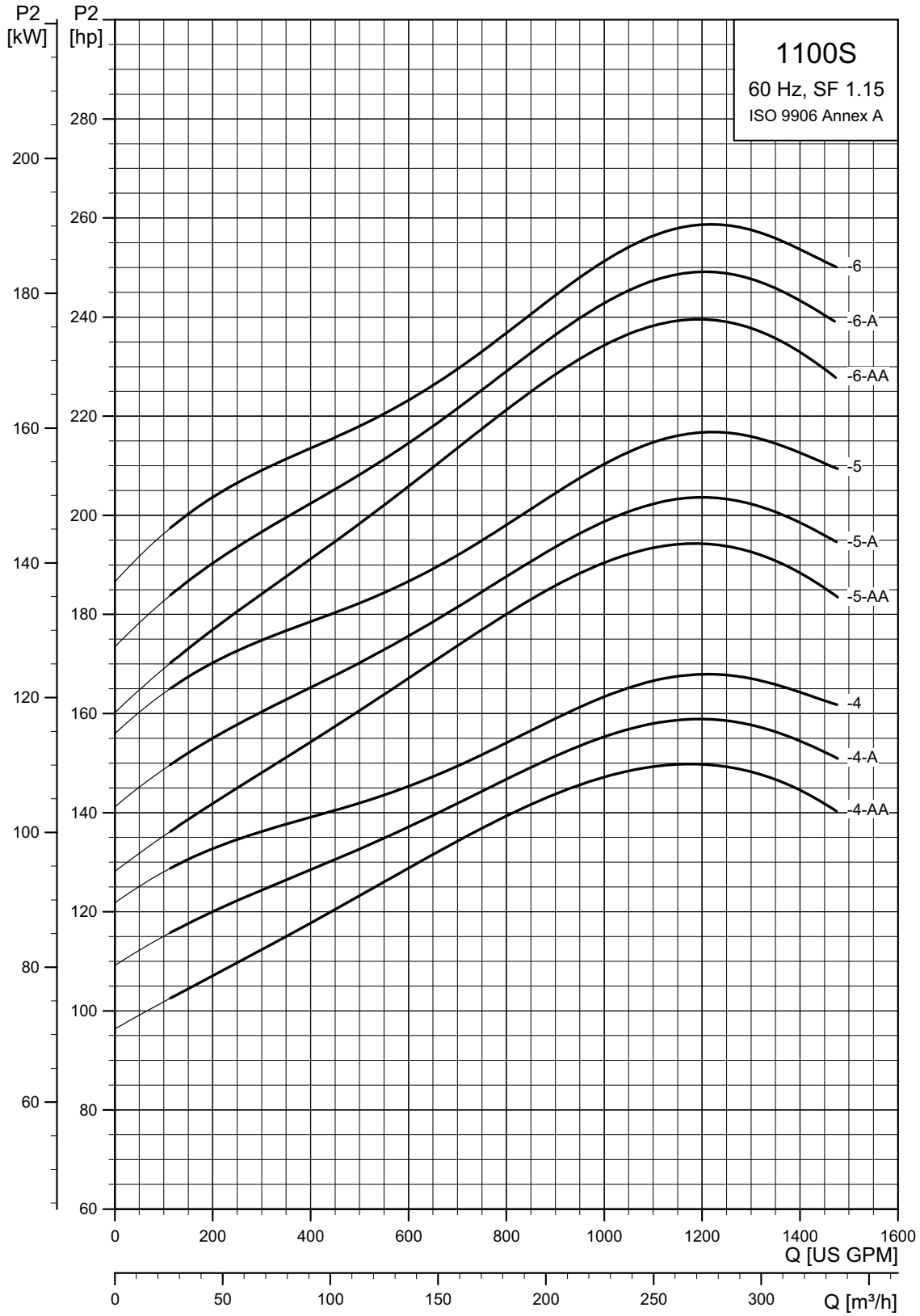

TM05 0270 0112

1100S (1100 gpm)

Pump model	Nom. head [ft]	Ph	Volts [V]	Motor [Hp]	Dimensions					Net weight (complete) [lb]
					A [in (mm)]	B [in (mm)]	C [in (mm)]	D [in (mm)]	E [in (mm)]	
1100S - Motor dia. 6 inch, 3 wire motor, 60 Hz, rated flow 1100 gpm (6" NPT)										
1100S300-1A	67	3	230	30 ▲	66.66 (1693)	35.56 (903)	31.11 (790)	5.63 (143)	9.30 (236)	261.0
		3	460	30 ▲	66.66 (1693)	35.56 (903)	31.11 (790)	5.63 (143)	9.30 (236)	261.0
1100S400-1	108	3	460	40 ▲	71.38 (1813)	40.28 (1023)	31.11 (790)	5.63 (143)	9.30 (236)	290.6
1100S600-2AA	155	3	460	60 ◆	—	—	38.04 (966)	—	9.30 (236)	—
1100S - Motor dia. 8 inch, 3 wire motor, 60 Hz, rated flow 1100 gpm (6" NPT)										
1100S400-1	108	3	460	40 *	74.81 (1900)	43.71 (1110)	31.11 (790)	7.56 (192)	9.41 (239)	407.2
1100S600-2AA	155	3	460	60 *	88.04 (2236)	50.00 (1270)	38.04 (966)	7.56 (192)	9.41 (239)	501.8
1100S750-2A	197	3	460	75 *	91.19 (2316)	53.15 (1350)	38.04 (966)	7.56 (192)	9.41 (239)	534.8
1100S1000-2	227	3	460	100 *	100.63 (2556)	62.60 (1590)	38.04 (966)	7.56 (192)	9.41 (239)	633.8
1100S1000-3AA	286	3	460	100 *	107.56 (2732)	62.60 (1590)	44.97 (1142)	7.56 (192)	9.41 (239)	655.9
1100S1250-3A	316	3	460	125 *	117.01 (2972)	72.05 (1830)	44.97 (1142)	7.56 (192)	9.41 (239)	757.1
1100S1250-3	346	3	460	125 *	117.01 (2972)	72.05 (1830)	44.97 (1142)	7.56 (192)	9.41 (239)	757.1
1100S1500-4AA	405	3	460	150 *	133.00 (3378)	81.11 (2060)	51.89 (1318)	7.56 (192)	9.41 (239)	889.1
1100S1500-4A	435	3	460	150 *	133.00 (3378)	81.11 (2060)	51.89 (1318)	7.56 (192)	9.41 (239)	889.1
1100S1500-4	465	3	460	150 *	133.00 (3378)	81.11 (2060)	51.89 (1318)	7.56 (192)	9.41 (239)	889.1
1100S1750-5AA	524	3	460	175 *	—	—	58.82 (1494)	—	9.41 (239)	—
1100S1750-5A	554	3	460	175 *	—	—	58.82 (1494)	—	9.41 (239)	—
1100S2000-5	584	3	460	200 *	—	—	58.82 (1494)	—	9.41 (239)	—
1100S - Motor dia. 10 inch, 3 wire motor, 60 Hz, rated flow 1100 gpm (6" NPT)										
1100S1750-5AA	524	3	460	175 †	132.45 (3364)	73.63 (1870)	58.82 (1494)	9.34 (237)	9.85 (250)	1142.2
1100S1750-5A -1800	554	3	460	175 †	132.45 (3364)	73.63 (1870)	58.82 (1494)	9.34 (237)	9.85 (250)	1137.0
1100S2000-5	584	3	460	200 †	140.32 (3564)	81.5 (2070)	58.82 (1494)	9.34 (237)	9.85 (250)	1285.2
1100S2500-6AA -2600	703	3	460	250 †	160.24 (4070)	94.49 (2400)	65.75 (1670)	9.34 (237)	9.85 (250)	1478.0
1100S2500-6A-2600	673	3	460	250 †	160.24 (4070)	94.49 (2400)	65.75 (1670)	9.34 (237)	9.85 (250)	1483.2
1100S2500-6-2600	703	3	460	250 †	160.24 (4070)	94.49 (2400)	65.75 (1670)	9.34 (237)	9.85 (250)	1483.2

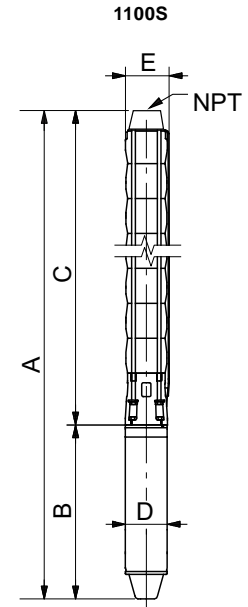

E = Maximum diameter of pump including cable guard and motor.

TM05 2532 0212

Notes:

Control box is required for 3-wire, single-phase applications. Data does not include control box.

- MS402 motor.
- MS4000 motor.
- ▲ MS6 motor.
- △ MMS6000 motor.
- ★ MMS8000 motor.
- ◆ Takes MS6 motor; not available as complete.
- ☆ Takes MMS6000 motor; not available as complete.
- * Takes MMS8000 motor; not available as complete.
- † Takes MMS10000 motor; not available as complete.

Electrical data

Grundfos submersible pump motors - 60 Hz

Grundfos submersible pump motors - 60 Hz													
Hp	Ph	Volt [V]	S.F.	Circuit breaker or fuses		Amperage		Full load		Max. thrust [lbs]	Nameplate number	Product number	
				Std.	Delay	Start [A]	Max. [A]	Eff. [%]	Power factor [%]				
4-inch, single-phase, 2-wire motors (control box not required)													
.5	1	115	1.60	35	15	55.0	12.0	62	76	900	79922102	96465574	
.5			1.60	15	7	34.5	6.0	62	76	750	79952102	96465616	
.75			1.50	20	9	40.5	8.4	62	75	750	79952103	96465618	
1	1	230	1.40	25	12	48.4	9.8	63	82	750	79952104	96465620	
1.5			1.30	35	15	62.0	13.1	64	85	750	79952105	96465622	
4-inch, single-phase, 3-wire motors													
.5	1	115	1.60	35	15	42.5	12.0	61	76	900	79423102	96023039	
.5			1.60	15	7	21.5	6.0	62	76	750	79453102	96465606	
.75			1.50	20	9	31.4	8.4	62	75	750	79453103	96465608	
1	1	230	1.40	25	12	37.0	9.8	63	82	750	79453104	9646510	
1.5			1.30	35	15	45.9	11.6	69	89	750	79453105	96465612	
4-inch, three-phase, 3-wire motors													
1.5	3	230	1.30	15	8	40.3	7.3	75	72	750	79302005	96465629	
		460	1.30	10	4	20.1	3.7	75	72	750	79362005	96465651	
		575	1.30	10	4	16.1	2.9	75	72	750	79392005	96785912	
2	3	230	1.25	20	10	48	8.7	76	75	750	79302006	96465630	
		460	1.25	10	5	24	4.4	76	75	750	79362006	96465652	
		575	1.25	10	4	19.2	3.5	76	75	750	79392006	96785917	
3	3	230	1.15	30	15	56	12.2	77	75	1000	79304507	96405801	
		460	1.15	15	7	28	6.1	77	75	1000	79354507	96405810	
		575	1.15	15	6	22	4.8	77	75	1000	79394507	96405815	
5	3	230	1.15	40	25	108	19.8	80	82	1000	79304509	96405802	
		460	1.15	20	12	54	9.9	80	82	1000	79354509	96405811	
		575	1.15	15	9	54	7.9	80	82	1000	79394509	96405816	
7.5	3	230	1.15	60	30	130	25.0	81	82	1000	79305511	96405805	
		460	1.15	35	15	67	13.2	81	82	1000	79355511	96405814	
		575	1.15	30	15	67	10.6	81	82	1000	79395511	96405819	
6-inch, three-phase, 3-wire motors													
7.5	3	230	1.15	60	35	119	26.4	80.5	76	1000	78305511	96405781	
		460	1.15	30	15	59	13.2	80.5	76	1000	78355511	96405794	
		230	1.15	80	45	156	34.0	82.5	79	1000	78305512	96405782	
10	3	460	1.15	40	20	78	17.0	82.0	79	1000	78355512	96405795	
		15	230	1.15	150	80	343	66.0	84.0	81	4400	78305516	96405784
			460	1.15	60	30	115	24.5	82.5	82	4400	78305514	96405796
20	3	230	1.15	150	80	343	66.0	84	81	4400	78305516	96405784	
		460	1.15	80	40	172	33.0	84	82	4400	78355516	96405797	
		25	3	460	1.15	100	50	217	41.0	84.5	80	4400	78355517
30	3	460	1.15	110	60	237	46.5	85	83	4400	78355518	96405799	
40	3	460	1.15	150	80	320	64.0	85	82	4400	78355520	96405800	
50	3	460	1.15	225	125	470	68.7	84	83	13000	96476890	96023200	
8-inch, three-phase, 3-wire motors													
40	3	460	1.15	175	100	380	55.7	83	85	13000	96530180	96023204	
50	3	460	1.15	225	125	550	67.8	84	85	13000	96530182	96023205	
60	3	460	1.15	250	150	640	80.4	86	85	13000	96476891	96023206	
75	3	460	1.15	300	175	580	97.4	86	86	13000	96476892	96023207	
100	3	460	1.15	400	225	570	130.4	87	86	13000	96476893	96023208	
125	3	460	1.15	500	300	600	160.0	87	87	13000	96476894	96023209	
150	3	460	1.15	600	350	580	191.3	86	87	13000	96511375	96023210	
10-inch, three-phase, 3-wire motors													
175	3	460	1.15	700	400	570	230.4	88	85	13000	96521619	96937300	
200	3	460	1.15	800	500	620	265.2	87	82	13000	96540302	96937302	
250	3	460	1.15	1100	600	610	352.2	87	79	13000	96463669	96937316	

Other motor manufacturers

- Hitachi motors: Refer to the Hitachi submersible motors application maintenance manual.
- Franklin motors: Refer to the Franklin submersible motors application maintenance manual.

7. Accessories

MP 204

The MP 204 is an electronic motor protector, designed for the protection of an asynchronous motor or a pump.

The motor protector consists of:

- a cabinet incorporating transformers and electronics
- a control panel with operating buttons and display for reading of data.

The MP 204 operates with two sets of limits:

- a set of warning limits and
- a set of trip limits.

If one or more of the warning limits are exceeded, the motor continues to run, but the warnings will appear in the MP 204 display.

Some values only have a warning limit.

The warning can also be read out by means of the Grundfos R100 remote control.

If one of the trip limits is exceeded, the trip relay will stop the motor. At the same time, the signal relay is operating to indicate that the limit has been exceeded.

Applications

The MP 204 can be used as a stand-alone motor protector.

The MP 204 can be monitored via a Grundfos GENiBus.

The power supply to the MP 204 is in parallel with the supply to the motor. Motor currents up to 120 A are passed directly through the MP 204. The MP 204 protects the motor primarily by measuring the motor current by means of a true RMS measurement. The MP 204 disconnects the contactor if, for example, the current exceeds the preset value.

Secondarily, the motor is protected via temperature measuring by a Tempcon sensor, a Pt100/Pt1000 sensor and a PTC sensor/thermal switch.

The MP 204 is designed for single- and three-phase motors. In single-phase motors, the starting and run capacitors are also measured. $\cos \varphi$ is measured in both single- and three-phase systems.

Benefits

The MP 204 offers these benefits:

- Suitable for both single- and three-phase motors
- Dry-running protection
- Overload protection
- Very high accuracy
- Made for submersible pumps.

Many monitoring options

The MP 204 monitors the following parameters:

- Insulation resistance before start-up
- Temperature (Tempcon, Pt sensor and PTC/thermal switch)
- Overload/underload
- Overvoltage/undervoltage
- Phase sequence
- Phase failure
- Power factor
- Power consumption
- Harmonic distortion
- Operating hours and number of starts.



Fig. 21 MP 204

Five sizes of single-turn transformers, 120-999 A.
Note: Monitoring of motor temperature is not possible when single-turn transformers are used.

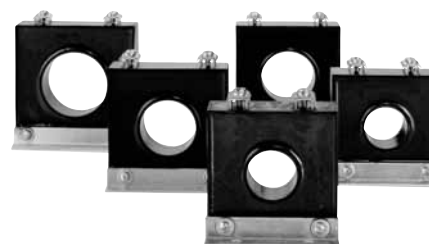

Fig. 22 Single-turn transformers

Product numbers

Product	Product number
MP 204	96079927
R100	625333

TM03 1471 2205

TM03 2033 3505

Functions

- Phase-sequence monitoring
- Indication of current or temperature (user selection)
- Indication of temperature in °F or °C (user selection)
- 4-digit, 7-segment display
- Setting and status reading with the R100
- Setting and status reading via the GENIbus.

Tripping conditions

- Overload
- Underload (dry running)
- Temperature (Tempcon sensor, PTC/thermal switch and Pt sensor)
- Phase failure
- Phase sequence
- Overvoltage
- Undervoltage
- Power factor ($\cos \varphi$)
- Current unbalance.

Warnings

- Overload
 - Underload
 - Temperature (Tempcon and Pt sensor)
 - Overvoltage
 - Undervoltage
 - Power factor ($\cos \varphi$)
- Note:** In connection with single- and three-phase connection.
- Run capacitor (single-phase operation)
 - Starting capacitor (single-phase operation)
 - Loss of communication in network
 - Harmonic distortion.

Learning function

- Phase sequence (three-phase operation)
- Run capacitor (single-phase operation)
- Starting capacitor (single-phase operation)
- Identification and measurement of Pt100/Pt1000 sensor circuit.

External current transformers

When fitted with external current transformers, the MP 204 unit can handle currents from 120 to 999 A. Grundfos can supply approved current transformers from stock (200/5A, 300/5A, 500/5A, 750/5A, 1000/5A).

Remote control R100

The R100 remote control from Grundfos allows for wireless infrared remote control of your MP 204 unit.

With the R100, you get access to a full range of options such as factory setting adjustment, service and fault finding.

Ready for bus communication

The MP 204 allows for monitoring and communication via GENIbus — a Grundfos-designed bus for exchange of pump data, alarms, status information, and setpoints. This enables users to connect the MP 204 to, for instance, SCADA systems.

Technical data - MP 204

Enclosure class	IP 20
Ambient temperature	-4 °F to +140 °F (-20 °C to +60 °C)
Relative air humidity	99%
Voltage range	100-480 VAC
Current range	3-999 A
Frequency	50 to 60 Hz
IEC trip class	1-45
Special Grundfos trip class	0.1 to 30 s
Voltage variation	-25 %/+15 % of nominal voltage
Approvals	EN 60947, EN 60335, UL/CSA 508
Marking	CE, cUL, C-tick
Consumption	Max. 5 W
Plastic type	Black PC / ABS

	Measuring range	Accuracy	Resolution
Current without external current transformers	3-120 A	±1 %	0.1 A
Current with external current transformers	120-999 A	±1 %	1 A
Phase-to-phase voltage	80-610 VAC	±1 %	1 V
Frequency	47-63 Hz	±1 %	0.5 Hz
Power	0-1 MW	±2 %	1 W
Power factor	0-0.99	±2 %	0.01
Energy consumption	0-4x10 ⁹ kWh	±5 %	1 kWh

IO 112	Description	Product number
	<p>The IO 112 is a measuring module and a 1-channel protection unit for use in connection with the MP 204 motor protection unit. The module can be used for protection of pump against other factors than the electrical conditions, for instance dry-running. It can also be used as a stand-alone protection module.</p> <p>The IO 112 interface has three inputs for measured values one potentiometer for setting of limits indicator lights indicating the</p> <ul style="list-style-type: none"> • measured value of the input • value of the limit set • alarm source • pump status. <p>Electrical data:</p> <ul style="list-style-type: none"> • Supply voltage: 24 VAC ±10% 50/60 Hz or 24 VDC ±10% • Supply current: Min. 2.4 A; max. 8 A • Power consumption: Max. 5 W <p>Ambient temperature: -13 °F to +149 °F (-25 °C to +65 °C)</p> <ul style="list-style-type: none"> • Enclosure class: IP 20 	96651601

Control functions

This table describes the protection provided by MP 204.

Control parameters	Function	Problem	Advantages
Temperature	<p>MS</p> <p>The motor temperature is measured by means of the built-in Tempcon temperature transmitter and a signal is sent to MP 204 via the phase leads. In MP 204 the measured temperature is compared with the factory-set value (167 °F (75 °C)).</p>	Overload, frequent starts/stops, operation against blocked discharge pipe, insufficient flow velocity past the motor.	Longer motor life, safe operating conditions, service indication.
	<p>MMS</p> <p>The motor temperature is measured by means of the Pt100. The signal is sent to the MP 204 where the measured temperature is compared with the factory-set value. Temperature protection requires a submersible motor with a Pt100.</p> <p>The motor temperature must be monitored during frequency converter operation.</p>		
Overvoltage/undervoltage	If the set trip value is exceeded, the motor will stop.	The installation is close to a transformer. The mains do not absorb load variations.	Important installation parameter, possibility of improving operating conditions.
Overload	The motor power input is measured on each of the three phases. The registered power input is an average of these three values. If the factory-set value is exceeded, the motor will stop.	Incorrect sizing of pump/motor, voltage supply failure, defective cable, blocking, wear or corrosion.	Longer pump life, safe operating conditions, service indication.
Underload (dry running)	The motor power input is measured on each of the three phases. The registered power input is an average of these three values. If the average value is lower than the factory-set value, the motor will stop.	Pump exposed to dry running or underload, for example caused by wear.	Traditional dry-running protection is no longer necessary, no extra cables.
Current unbalance	The power input of the motor is measured on each of the three phases.	Mains load is uneven, incipient motor defect, phase voltages diverging.	Motor protection against overload, service indication.
Phase sequence	MP 204 and motor are installed so that the phase sequence corresponds to correct direction of rotation. MP 204 monitors changes in the phase sequence.	Two phases are wrongly connected.	Ensures correct pump performance.
Phase failure	MP 204 checks the phases connected, phase failure will cause an alarm.	Phase failure	Indication of phase failure, and alarm.

R100 menus

0. GENERAL

See the operating instructions for the R100.

1. OPERATION

- Operating mode
- Actual trip
- Actual warning 1
- Actual warning 2
- Alarm log 1
- Alarm log 2
- Alarm log 3
- Alarm log 4
- Alarm log 5.

2. STATUS

Display of

- Supply overview
- Average current
- Average voltage
- Tempcon sensor
- Pt100/Pt1000 sensor
- *Power input and energy consumption* (described in the following)
- Energy trip counter
- Phase sequence
- Current unbalance
- Operating hours and number of starts
- Trip counter of hours and starts
- Starting capacitor
- Run capacitor
- Insulation resistance
- Cos φ
- Harmonic distortion.

3. LIMITS

Display and setting of warning and trip limits.

- Tempcon sensor
- Pt sensor
- Tripping current
- Current warning
- Nominal voltage
- Voltage limits
- Current unbalance
- Starting capacitor
- Run capacitor
- Insulation resistance
- Cos φ trip
- Cos φ warning.

4. INSTALLATION

Setting and display of

- Supply mains
- Trip class (described in the following)
- Trip delay
- External current transformers
- Power-on delay
- Restarting (described in the following)
- Automatic restarting (described in the following)
- Tempcon sensor
- Pt sensor
- Insulation resistance measurement
- PTC/thermal switch
- Resetting of trip counters
- Service interval
- Number of automatic restarts
- Units/display
- MP 204 display
- GENIbus ID number
- Learning function.

Power input and energy consumption

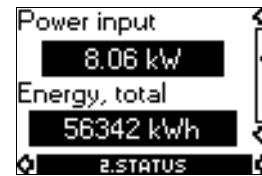

Actual input power and motor energy consumption.

The energy consumption is an accumulated value which cannot be reset.

The power is calculated like this:

$$U_{\text{average}} = \frac{U_{L1-L2} + U_{L2-L3} + U_{L3-L1}}{3} [\text{V}]$$

$$I_{\text{average}} = \frac{I_{L1} + I_{L2} + I_{L3}}{3} [\text{A}]$$

$$\cos\varphi_{\text{average}} = \frac{\cos\varphi_{L1} + \cos\varphi_{L2} + \cos\varphi_{L3}}{3} [-]$$

$$P = (U_{\text{average}} \times I_{\text{average}} \times \sqrt{3} \times \cos\varphi_{\text{average}}) [\text{W}]$$

Trip class

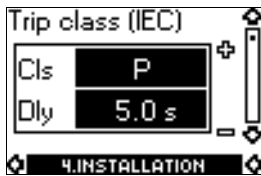

Line 1: Select IEC trip class (1 to 45).

If manual indication of trip delay in the case of overload is required, select trip class "P".

Factory setting:

- Cls (trip class): P.

Line 2: Select trip delay.

Factory setting:

- Dly (trip delay): 10 s.

Restarting

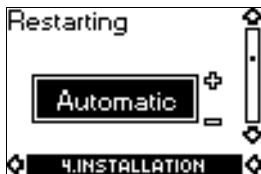

Set whether restarting after tripping is to be

- *Automatic* (factory setting)
- *Manual*.

Setting of time, see section "Automatic restarting".

Automatic restarting



Set the time after which the MP 204 is to attempt automatic restarting of motor after cut-out.

The time runs from the moment when the value which triggered the fault has returned to normal.

Factory setting:

- 300 s.

G100 gateway for communication with Grundfos products

The G100 offers a wide selection of options for integration of Grundfos products provided with GENIbus interface into main control and monitoring systems.

The G100 enables a pump installation to meet future demands for optimum pump operation in terms of reliability, operating costs, centralization and automation.



Fig. 23 G100

GR5940

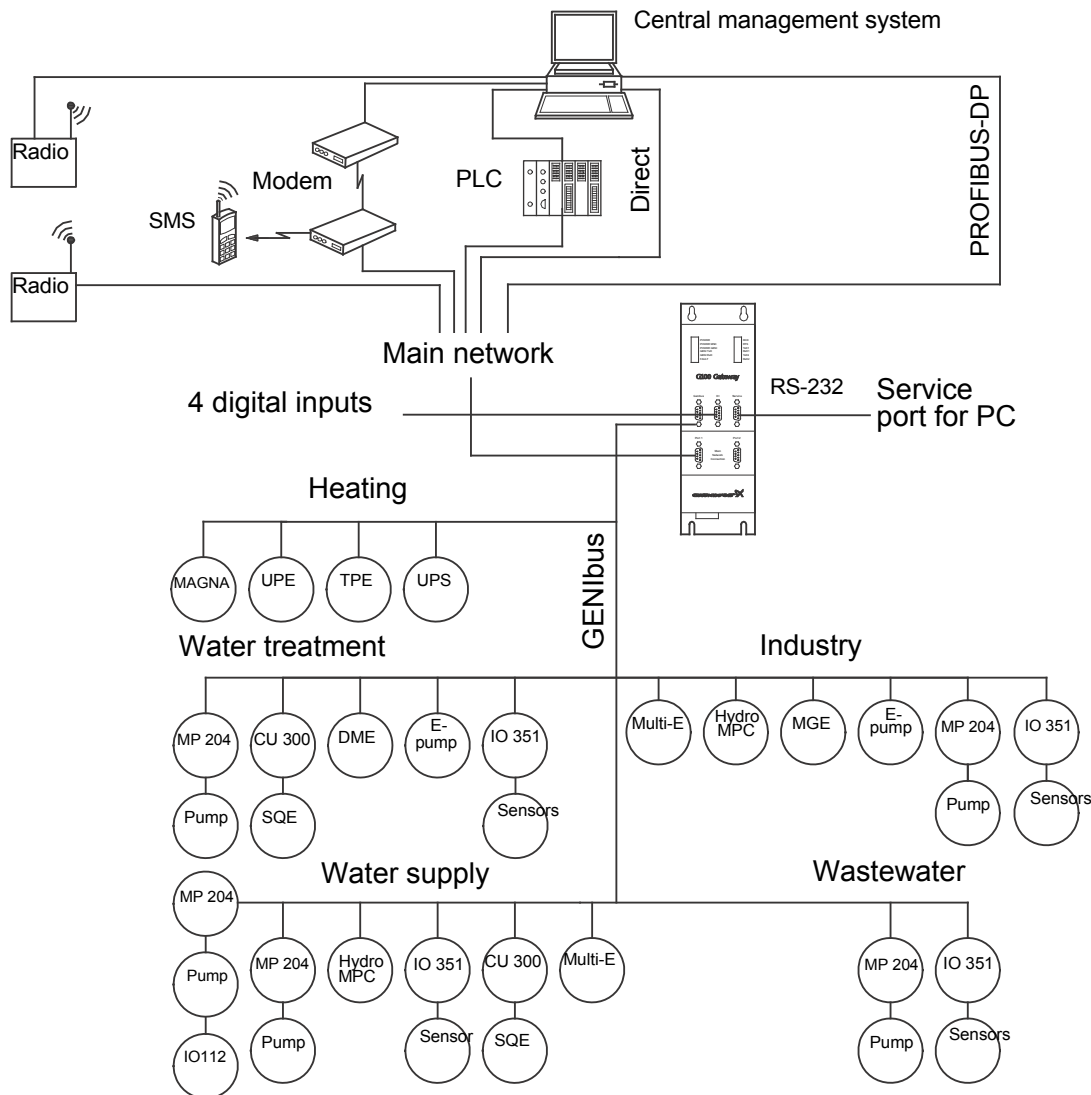

Fig. 24 Examples of G100 applications

TM03 9224 3607

Product description

The G100 Gateway enables communication of operating data, such as measured values and setpoints, between Grundfos products with GENIbus interface and a main network for control and monitoring.

As indicated in the illustration on page 92, the G100 is suitable for use in applications such as water supply, water treatment, wastewater, building automation and industry.

Common to above applications is that downtime is usually costly, and extra investments are therefore often made to achieve maximum reliability by monitoring selected operating variables.

The day-to-day operation, such as starting and stopping of pumps and changing of setpoints, can also be effected from the main system by communication with the G100. In addition, the G100 can be set up to send event-controlled status indications such as alarms via the SMS to mobile phones, and to make automatic alarm call-backs to a central management system.

Data logging

Besides the possibility of data communication, the G100 offers logging of up to 350,000 time-stamped data. The logged data can be transmitted to the main system or a PC for further analysis in a spreadsheet or similar program.

For the data logging, the "PC Tool G100 Data Log" software tool is used. The tool is part of the PC Tool G100 package, which is supplied with the G100.

Other features

- Four digital inputs.
- Stop of all pumps in case of failing communication with the management system (optional).
- Access code for modem communication (optional).
- Alarm log.

Installation

Installation of the G100 is effected by the system integrator. The G100 is connected to the GENIbus as well as to the main network. All units on the GENIbus can thus be controlled from a central management system on the main network.

The "G100 Support Files" CD-ROM supplied with the G100 contains examples of programs to be used when the G100 is connected to the various main network systems. Included is also a description of the data points available in Grundfos products with GENIbus interface.

The "PC Tool G100" software tool included can be used for the installation and use of G100.

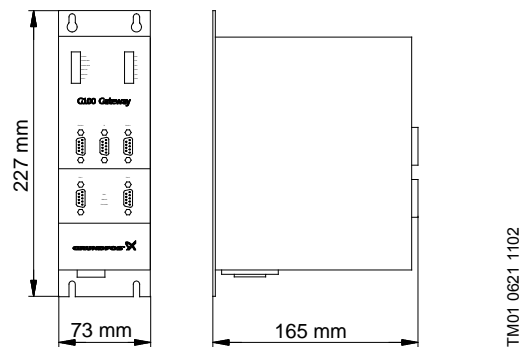

Fig. 25 Dimensional sketch

Technical data

Overview of protocols

Main system	Software protocol
PROFIBUS-DP	DP
Radio	Satt Control COMLI/Modbus
Modem	Satt Control COMLI/Modbus
PLC	Satt Control COMLI/Modbus
GSM mobile phone	SMS, UCP

Other possible connections

GENIbus RS-485:	Connection of up to 32 units.
Service port RS-232:	For direct connection to a PC or via radio modem.
Digital inputs:	4.
Voltage supply:	1 x 110-240 V, 50/60 Hz.
Ambient temperature:	In operation: -4 °F to +140 °F (-20 °C to +60 °C).
Enclosure class:	IP 20.
Weight:	1.8 kg.

Accessories

- PC Tool G100 package (supplied with the product)
- G100 Support Files CD-ROM (supplied with product)

Product numbers

Product	Product number
G100 with Profibus-DP expansion board*	96411135
G100 with Radio/Modem/PLC expansion board*	96411136
G100 Basic Version*	96411137
PC Tool G100 package	96415783

* CD-ROM with G100 Support Files included.

Connecting pieces

The tables below show the range of connecting pieces for connection of thread-to-flange and thread-to-thread.

Thread-to- thread



TM01 2397 1698 - GrA2555

Fig. 26 Dimensional sketch and photo of connecting piece thread-to-thread

Type	Connecting piece	Dimensions			Product number	
		Thread-to-thread		L [in (mm)]	304 stainless steel	316 stainless steel
		A	B			
385S	NPT 5 → NPT 4	NPT 5	NPT 4	4.76 (121)	190064	190586
475S	NPT 5 → NPT 6	NPT 5	NPT 6	5.91 (150)	190070	190592
625S 800S 1100S	NPT 6 → NPT 5	NPT 6	NPT 5	5.91 (150)	200135	200645

Zinc anodes

Application

Cathodic protection by means of zinc can be used for corrosion protection of SP pumps in chloride-containing liquids such as brackish water and seawater.

Sacrificial anodes are placed on the outside of the pump and motor as protection against corrosion.

The number of anodes required depends on the pump and motor in question.

Please contact Grundfos for further details.

Liquid temperatures

- Seawater:
Up to 95 °F (35 °C).
- Brackish water (min. 1500 ppm (g/m³) chloride):
Up to 95 °F (35 °C).

Anode life

The zinc anodes have a life of one to four years, depending on operating conditions (temperature, flow and chloride content).

Product numbers of zinc anodes

Zinc anodes for pumps										
Product number	Used for pump type									
	SP 65 to 75S	85S	150S	230S	300S	385S	475S	625S	800S	1100S
96421444	●	-	-	-	-	-	-	-	-	-
96421445	-	●	●	●	●	-	-	-	-	-
96421447	-	-	-	-	-	●	●	-	-	-
96421448	-	-	-	-	-	-	●	-	-	-
96421449	-	-	-	-	-	-	-	●	-	-
96421450	-	-	-	-	-	-	-	●	●	●

Zinc anodes for motors			
4" motors	6" motors	8" motors	10" motors
96421444	96421446	96421450	96564808

SA-SPM 5 control boxes

Application

SA-SPM 5 control boxes are used as starting units for single-phase, 3-wire motors, types MS 402B with power input lower than or equal to 1.5 hp (1.1 kW).

SA-SPM 5 is available in two versions, standard and DeLuxe. The standard version incorporates a motor-protective circuit breaker and thus protects the motor against overload. The DeLuxe version is identical to the standard version with the following addition a motor contactor is included for connection and disconnection of the power supply.

Technical data

Enclosure class:	IP 42.
Ambient temperature:	-4 °F to +140 °F (-20 °C to +60 °C).
Relative humidity:	Maximum 95 %, normal non-aggressive atmosphere.



Fig. 27 SA-SPM 5 control box

TM03 8150 0607

Product numbers

Product	Description					Product number
	1 x 220-230 V	1.5 hp	2.0 hp	3.0 hp	5.0 hp	
SA-SPM 5 (Standard version)	●	●	-	-	-	91126212
SA-SPM 5 (DeLuxe version)	●	●	-	-	-	91126213
SA-SPM 5 (Standard version)	●	-	●	-	-	91126214
SA-SPM 5 (DeLuxe version)	●	-	●	-	-	91126215
SA-SPM 5 (Standard version)	●	-	-	●	-	91126216
SA-SPM 5 (DeLuxe version)	●	-	-	●	-	91126217
SA-SPM 5 (Standard version)	●	-	-	-	●	91126218
SA-SPM 5 (DeLuxe version)	●	-	-	-	●	91126219

Pt100

The Pt100 sensor offers these features:

- Continuous monitoring of the motor temperature
- Protection against too high motor temperature.

Protecting the motor against too high motor temperature is the simplest and cheapest way of avoiding that motor lifetime is reduced. Pt100 ensures that operating conditions are not exceeded and indicates when it is time for service of the motor.

Monitoring and protection by means of Pt100 require the following parts:

- Pt100 sensor
- Relay, type PR 5714
- Cable.

The PR 5714 relay is fitted with a Pt100 module. For both relays the following temperature limits are preset on delivery:

- +60 °C (+140 °F) warning limit
- +75 °C (+167 °F) stop limit.

Technical data

Relay type	
PR 5714	
Enclosure class	IP 65 (mounted in a control panel)
Ambient temperature	-4 °F to +140 °F (-20 °C to +60 °C)
Relative humidity	95 % (condensating)
Voltage variation	• 1 x 24-230 VAC ±10 %, 50 - 60 Hz. • 24-250 VDC ±20 %.
Approvals	UL, DNV
Mark	CE

Pt100 sensor with/without PR 5714 relay and cable	Cable length [ft (m)]	PR 5714	Product number		
			MS6	MMS 6000, MMS 8000	MMS 10000, MMS 12000
	65.6 (20)	Yes	96408953	96494596	96437287
	131.2 (40)	Yes	96408681	96494597	96437288
	196.9 (60)	Yes	96408954	96494598	96437289
	262.5 (80)	Yes	96408955	96494599	96437290
	328.1 (100)	Yes	96408956	96494610	96437291
	65.6 (20)	No	96658626	96658629	96658633
	131.2 (40)	No	96658627	96658630	96658634
	196.9 (60)	No	96658628	96658631	96658635
	262.5 (80)	No	96658637	96658632	96658636
	328.1 (100)	No	96658638	96658639	96658640

PR 5714 relay	Voltage	Product number
	24-230 VAC, 50/60 Hz / 24-250 VDC	96621274

Pt100 sensor including cable	Cable length [ft (m)]	Product number	
		MS6, MMS 6000, MMS 8000	MMS 10000 MMS 12000
	65.6 (20)	96408957	96437784
	131.2 (40)	96408684	96437785
	196.9 (60)	96408958	96437786
	262.5 (80)	96408959	96437787
	328.1 (100)	96408960	96437788

Staybolts for Pt100	Description	Product number
	Bolt KIT for Pt100 (for MS6)	96611899

8. Energy consumption

Energy consumption of submersible pumps

The percentage distribution of service life costs of a submersible pump for water supply is:

- 5 % initial costs (pump)
- 85 % operating costs / energy consumption
- 10 % maintenance costs.

It is obvious that the highest savings can be achieved within energy consumption!

The annual energy consumption, E, of a submersible pump can be calculated as follows:

$$E = c \times h \times P_1 \text{ (EURO)}$$

c = specific energy price (EURO/kWh)

h = operating hours/year (hours)

P₁ = power input of the submersible pump (kW).

Example: Calculation of the annual energy consumption of the submersible pump, type 625S-3.

625S-3 with MS 8000, 45 kW, 3 x 460 V, 60 Hz.

Duty point:

Flow rate: Q = 120 m³/h

Total head: H = 102 m

Specific energy price: c = EURO 0.1/kWh
(consisting of day and night rate)

Operating hours/year: h = 3200.

$$P_1 = \frac{Q \times H \times \rho}{367 \times \eta_{\text{pump}} \times \eta_{\text{motor}}} \text{ in kW}$$

Q = m³/h

H = m

Density ρ = kg/dm³ (assumed 1)

367 = conversion factor

η_{motor} = (example 84.5 %, in equation 0.845)

η_{pump} = (not to be confused with the stage efficiency curve).

By showing the P₂/Q curve we make it easier for you to calculate the energy consumption.

$$P_1 = \frac{P_2}{\eta_{\text{motor}}}$$

P₂ = 26 kW (power requirement of 625S-3 pump at 20 m³/h, from curve P₂ / Q on page 72).

Calculation of motor efficiency at duty point

As standard the SP 625S-3 is equipped with a 45 kW MS6 motor.

At duty point (Q = 120 m³/h) the pump requires 44 kW, thus:

a motor load of 87 % (44 kW / 45 kW) and a power reserve of 2 %.

From the table on page 72 the motor efficiency can be read as:

84.6 % at a load of 75 %. (η_{75%})

85.6 % at a load of 100 %. (η_{100%})

The interpolated value in this example is

η_{motor} = 85.1 %, η_{motor} = 0.851.

$$P_1 = \frac{44}{0.851} = 51.7 \text{ kW}$$

E = 0.1 EURO/kWh x 3200 h x 51.7 kW.

The annual energy costs amount to EURO 16544.

The pay-off time, A, (months) is calculated as follows:

$$A = \frac{\text{Purchase price of energy} - \text{efficiency pump}}{\text{Energy savings/year}} \times 12$$

Cable sizing

In order to obtain an economical duty of the pump the voltage drop should be low.

Today large water works already size cables for a maximum voltage drop of 1 %).

The hydraulic resistance in the discharge pipe should be as low as possible.

9. Cables

Grundfos offers submersible drop cables for all applications: 3-core cable, 4-core cable, single leads.

Cables for Grundfos 4" submersible motors are available with or without plugs. The submersible drop cable is chosen according to application and type of installation.

Standard version: Max. liquid temperature +140 °F +60 °C).

Hot water version: Max. liquid temperature +158 °F (+70 °C), for short periods up to 194 °F (+90 °C) (for MS only).

Tables indicating cable dimension in borehole

The tables indicate the maximum length of drop cables in meters from motor starter to pump at direct-on-line starting at different cable dimensions.

If star/delta starting is used the current will be reduced by $\sqrt{3}$ ($I \times 0.58$), meaning that the cable length may be $\sqrt{3}$ longer ($L \times 1.73$) than indicated in the tables.

If for example the operating current is 10 % lower than the full-load current, the cable may be 10 % longer than indicated in the tables.

The calculation of the cable length is based on a maximum voltage drop of 1 % to 3 % of the rated voltage and a water temperature of maximum +86 °F (30 °C).

In order to minimize operating losses the cable cross section may be increased compared to what is indicated in the tables. This is economical only if the borehole provides the necessary space, and if the operational time of the pump is long, especially if the operating voltage is below the rated voltage.

The table values are calculated on the basis of the formula:

Max. cable length of a single-phase submersible pump:

$$L = \frac{U \times \Delta U}{I \times 2 \times 100 \times \left(\cos \varphi \times \frac{\rho}{q} + \sin \varphi \times X_L \right)} \text{ [m]}$$

Max. cable length of a three-phase submersible pump:

$$L = \frac{U \times \Delta U}{I \times 1.73 \times 100 \times \left(\cos \varphi \times \frac{\rho}{q} + \sin \varphi \times X_L \right)} \text{ [m]}$$

where

U = Rated voltage [V]

ΔU = Voltage drop [%]

I = Rated current of the motor [A]

q = Cross-section of submersible drop cable [mm²]

X_L = Inductive resistance: 0.078×10^{-3} [Ω /m]

$\cos \varphi$ = Power factor

$\sin \varphi = \sqrt{1 - \cos^2 \varphi}$

ρ = Specific resistance: 0.02 [Ω mm²/m]

Example

Motor size: 30 kW, MMS 8000

Rated current: 64.0 A

Rated voltage: 3 x 460 V, 60 Hz

Starting method: Direct-on-line

Power factor: $\cos \varphi = 0.85$

Voltage drop: 3 %

Cross-section: 16 mm²

$\sin \varphi$: 0.53

$$L = \frac{460 \times 3}{64.0 \times 1.73 \times 100 \times \left(0.85 \times \frac{0.02}{16} + 0.53 \times 0.078 \times 10^{-3} \right)}$$

L = 113 m

Cable dimensions at 1 x 220 V, 60 Hz

Motor	kW	I _n [A]	1.5 mm ²	2.5 mm ²	4 mm ²	6 mm ²	10 mm ²
	0.25	3.3	96	159	254	379	624
	0.37	4.4	73	121	192	286	472
4"	0.55	6.6	48	80	127	189	311
	0.75	7.7	37	62	98	147	243
	1.1	9.0	30	50	79	118	196

Maximum cable length in meters from motor starter to pump.

Cable sizing chart

1 phase, 60 Hz															
Motor rating		Copper wire size													
Volts	Hp	14	12	10	8	6	4	2	0	00	000	0000	250	300	
Maximum motor cable length (motor service to entrance) [ft/m]															
115	0.33	130 (40)	210 (64)	340 (104)	540 (165)	840 (256)	1300 (396)	1960 (597)	2910 (887)						
	0.5	100 (30)	160 (49)	250 (76)	390 (119)	620 (189)	960 (293)	1460 (445)	2160 (658)						
	0.33	550 (168)	880 (268)	1390 (424)	2190 (668)	3400 (1036)	5250 (1600)	7960 (2426)							
	0.5	400 (122)	650 (198)	1020 (311)	1610 (491)	2510 (765)	3880 (1183)	5880 (1792)							
	0.75	300 (91)	480 (146)	760 (232)	1200 (366)	1870 (570)	2890 (881)	4370 (1332)	6470 (1972)						
	1	250 (76)	400 (122)	630 (192)	990 (302)	1540 (469)	2380 (725)	3610 (1100)	5360 (1634)	6520 (1987)					
	1.5	190 (58)	310 (94)	480 (146)	770 (235)	1200 (366)	1870 (570)	2850 (869)	4280 (1305)	5240 (1597)					
	2	150 (46)	250 (76)	390 (119)	620 (189)	970 (296)	1530 (466)	2360 (719)	3620 (1103)	4480 (1366)					
	3	120 (37)	190 (58)	300 (91)	470 (143)	750 (229)	1190 (363)	1850 (564)	2890 (881)	3610 (1100)					
	5			180 (55)	280 (85)	450 (137)	710 (216)	1110 (338)	1740 (530)	2170 (661)					
7.5				200 (61)	310 (94)	490 (149)	750 (229)	1140 (347)	1410 (430)						
10					250 (76)	390 (119)	600 (183)	930 (283)	1160 (354)						
3 phase, 60 Hz															
Motor rating		Copper wire size													
Volts	Hp	14	12	10	8	6	4	2	0	00	000	0000	250	300	
Maximum motor cable length (motor service to entrance) [ft/m]															
208	1.5	310 (94)	500 (152)	790 (241)	1260 (384)										
	2	240 (73)	390 (119)	610 (186)	970 (296)	1520 (463)									
	3	180 (55)	290 (88)	470 (143)	740 (226)	1160 (354)	1810 (552)								
	5		170 (52)	280 (85)	440 (134)	690 (210)	1080 (329)	1660 (506)							
	7.5			200 (61)	310 (94)	490 (149)	770 (235)	1180 (360)	1770 (539)						
	10				230 (70)	370 (113)	570 (174)	880 (268)	1330 (405)	1640 (500)					
	15					250 (76)	390 (119)	600 (183)	910 (277)	1110 (338)	1340 (408)				
	20						300 (91)	460 (140)	700 (213)	860 (262)	1050 (320)	1270 (387)			
	25							370 (113)	570 (174)	700 (213)	840 (256)	1030 (314)	1170 (357)		
	30								310 (94)	470 (143)	580 (177)	700 (213)	850 (259)	970 (296)	1110 (338)
230	1.5	360 (110)	580 (177)	920 (280)	1450 (442)										
	2	280 (85)	450 (137)	700 (213)	1110 (338)	1740 (530)									
	3	210 (64)	340 (104)	540 (165)	860 (262)	1340 (408)	2080 (634)								
	5		200 (61)	320 (98)	510 (155)	800 (244)	1240 (378)	1900 (579)							
	7.5			230 (70)	360 (110)	570 (174)	890 (271)	1350 (411)	2030 (619)						
	10				270 (82)	420 (128)	660 (201)	1010 (308)	1520 (463)	1870 (570)					
	15					290 (88)	450 (137)	690 (210)	1040 (317)	1280 (390)	1540 (469)				
	20						350 (107)	530 (162)	810 (247)	990 (302)	1200 (366)	1450 (442)			
	25							280 (85)	430 (131)	650 (198)	800 (244)	970 (296)	1170 (357)	1340 (408)	
	30								350 (107)	540 (165)	660 (201)	800 (244)	970 (296)	1110 (338)	1270 (387)
460	1.5	1700 (518)													
	2	1300 (396)	2070 (631)												
	3	1000 (305)	1600 (488)	2520 (768)											
	5	590 (180)	950 (290)	1500 (457)	2360 (719)										
	7.5	420 (128)	680 (207)	1070 (326)	1690 (515)	2640 (805)									
	10	310 (94)	500 (152)	790 (241)	1250 (381)	1960 (597)	3050 (930)								
	15			540 (165)	850 (259)	1340 (408)	2090 (637)	3200 (975)							
	20			410 (125)	650 (198)	1030 (314)	1610 (491)	2470 (753)	3730 (1137)						
	25				530 (162)	830 (253)	1300 (396)	1990 (607)	3010 (917)	3700 (1128)					
	30				430 (131)	680 (207)	1070 (326)	1640 (500)	2490 (759)	3060 (933)	3700 (1128)				
40						790 (241)	1210 (369)	1830 (558)	2250 (686)	2710 (826)	3290 (1003)				
50							640 (195)	980 (299)	1480 (451)	1810 (552)	2190 (668)	2650 (808)	3010 (917)		
60								830 (253)	1250 (381)	1540 (469)	1850 (564)	2240 (683)	2540 (774)	2890 (881)	
75									1030 (314)	1260 (384)	1520 (463)	1850 (564)	2100 (640)	2400 (732)	
100										940 (287)	1130 (344)	1380 (421)	1560 (475)	1790 (546)	
125												1080 (329)	1220 (372)	1390 (424)	
150													1050 (320)	1190 (363)	
200														1080 (329)	
250														1300 (396)	
														1080 (329)	

		3 phase, 60 Hz												
Motor rating		Copper wire size												
Volts	Hp	14	12	10	8	6	4	2	0	00	000	0000	250	300
		Maximum motor cable length (motor service to entrance) [ft/m]												
575	1.5	2620 (799)												
	2	2030 (619)												
	3	1580 (482)	2530 (771)											
	5	920 (280)	1480 (451)	2330 (710)										
	7.5	660 (201)	1060 (323)	1680 (512)	2650 (808)									
	10	490 (149)	780 (238)	1240 (378)	1950 (594)									
	15		530 (162)	850 (259)	1340 (408)	2090 (637)								
	20			650 (198)	1030 (314)	1610 (491)	2520 (768)							
	25			520 (158)	830 (253)	1300 (396)	2030 (619)	3110 (948)						
	30				680 (207)	1070 (326)	1670 (509)	2560 (780)	3880 (1183)					
	40					790 (241)	1240 (378)	1900 (579)	2860 (872)	3510 (1070)				
	50						1000 (305)	1540 (469)	2310 (704)	2840 (866)	3420 (1042)			
	60							850 (259)	1300 (396)	1960 (597)	2400 (732)	2890 (881)	3500 (1067)	
	75								1060 (323)	1600 (488)	1970 (600)	2380 (725)	2890 (881)	3290 (1003)

CAUTION: Use of wire size smaller than listed will void warranty.

Notes:

1. If aluminum conductor is used, multiply lengths by 0.5 Maximum allowable length of aluminum is considerably shorter than copper wire of same size.
2. The portion of the total cable which is between the service entrance and a 3Ø motor starter should not exceed 25% of the total maximum length to assure reliable starter operation. Single-phase control boxes may be connected at any point of the total cable length.
3. Cables #14 to #0000 are AWG sizes, and 250 to 300 are MCM sizes.

10. Friction loss tables

		Friction loss table - SCH 40 steel pipe								
U.S. gpm	U.S. gph	.5"	.75"	1"	1.25"	1.5"	2"	2.5"	3"	4"
		ID 0.622"	ID 0.824"	ID 1.049"	ID 1.380"	ID 1.610"	ID 2.067"	ID 2.469"	ID 3.068"	ID 4.026"
		Friction loss in feet of head per 100 feet of pipe								
2	120	4.8								
3	180	10.0	2.5							
4	240	17.1	4.2							
5	300	25.8	6.3	1.9						
6	360	36.5	8.9	2.7						
7	420	48.7	11.8	3.6						
8	480	62.7	15.0	4.5						
9	540	78.3	18.8	5.7						
10	600	95.9	23.0	6.9						
12	720		32.6	9.6	2.5	1.2				
14	840		43.5	12.8	3.3	1.5				
16	960		56.3	16.5	4.2	2.0				
20	1,200		86.1	25.1	6.3	2.9				
25	1,500			38.7	9.6	4.5	1.3			
30	1,800			54.6	13.6	6.3	1.8			
35	2,100			73.3	18.2	8.4	2.4			
40	2,400			95.0	23.5	10.8	3.1	1.3		
45	2,700				29.4	13.5	3.9	1.6		
50	3,000				36.0	16.4	4.7	1.9		
60	3,600				51.0	23.2	6.6	2.7		
70	4,200				68.8	31.3	8.9	3.6	1.2	
80	4,800				89.2	40.5	11.4	4.6	1.6	
90	5,400					51.0	14.2	5.8	2.0	
100	6,000					62.2	17.4	7.1	2.4	
120	7,200						24.7	10.1	3.4	
140	8,400						33.2	13.5	4.5	1.2
160	9,600						43.0	17.5	5.8	1.5
200	12,000						66.3	27.0	8.9	2.3
260	15,600							45.0	14.8	3.7
300	18,000							59.6	19.5	4.9

		Friction loss table - SCH 40 PVC pipe								
U.S. gpm	U.S. gph	.5"	.75"	1"	1.25"	1.5"	2"	2.5"	3"	4"
		ID 0.622"	ID 0.824"	ID 1.049"	ID 1.380"	ID 1.610"	ID 2.067"	ID 2.469"	ID 3.068"	ID 4.026"
		Friction loss in feet of head per 100 feet of pipe								
2	120	4.1								
3	180	8.7	2.2							
4	240	14.8	3.7							
5	300	22.2	5.7	1.8						
6	360	31.2	8.0	2.5						
7	420	41.5	10.6	3.3						
8	480	53.0	13.5	4.2						
9	540	66.0	16.8	5.2						
10	600	80.5	20.4	6.3	1.7					
12	720		28.6	8.9	2.3	1.1				
14	840		38.0	11.8	3.1	1.4				
16	960		48.6	15.1	4.0	1.9				
20	1,200		60.5	22.8	6.0	2.8				
25	1,500			38.7	9.1	4.3	1.3			
30	1,800				12.7	6.0	1.8			
35	2,100				16.9	8.0	2.4			
40	2,400				21.6	10.2	3.0	1.1		
45	2,700				28.0	12.5	3.8	1.4		
50	3,000					15.4	4.6	1.7		
60	3,600					21.6	6.4	2.3		
70	4,200					28.7	8.5	3.0	1.2	
80	4,800					36.8	10.9	3.8	1.4	
90	5,400					45.7	13.6	4.8	1.8	
100	6,000					56.6	16.5	5.7	2.2	
120	7,200						23.1	8.0	3.0	
140	8,400						30.6	10.5	4.0	1.1
160	9,600						39.3	13.4	5.0	1.4
200	12,000						66.3	20.1	7.6	2.1
260	15,600							32.4	12.2	3.4
300	18,000							42.1	15.8	4.4

Type of fitting and application	Pipe and fitting	Nominal size of fitting and pipe						
		1/2"	3/4"	1"	1.25"	1.5"	2"	2.5"
		Friction loss in equivalent length of straight pipe in feet						
Insert coupling	Plastic	3	3	3	3	3	3	3
Threaded adapter (plastic to thread)	Plastic	3	3	3	3	3	3	3
90° standard elbow	Steel	2	2	3	4	4	5	6
	Plastic	2	2	3	4	4	5	6
Standard tee (flow through run)	Steel	1	2	2	3	3	4	4
	Plastic	1	2	2	3	3	4	4
Standard tee (flow through side)	Steel	4	5	6	7	8	11	13
	Plastic	4	5	6	7	8	11	13
Gate valve ¹	Steel	1	1	1	1	2	2	2
Swing check valve ¹	Steel	5	7	9	12	13	17	21

Notes:

Based on Schedule 40 steel and plastic fittings

¹Friction loss figures are for screwed valves and are based on equivalent lengths of steel pipe.

11. Further product documentation

WebCAPS

WebCAPS is a **Web-based Computer Aided Product Selection** program available on www.grundfos.com.

WebCAPS contains detailed information on more than 185,000 Grundfos products in more than 20 languages.

In WebCAPS, all information is divided into 6 sections:

- Catalog
- Literature
- Service
- Sizing
- Replacement
- CAD drawings.

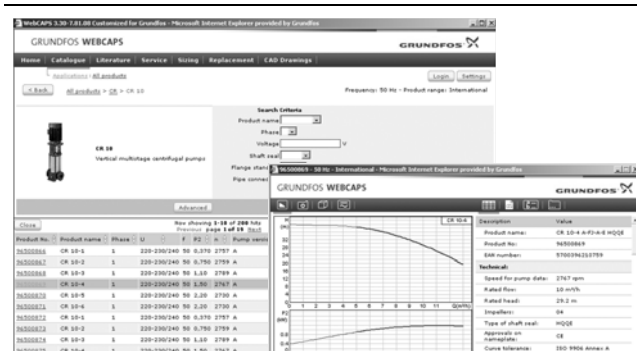
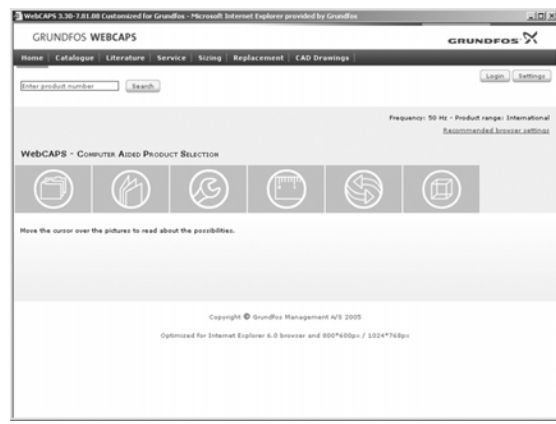

Catalog

This section is based on fields of application and pump types, and contains

- technical data
- curves (QH, Eta, P1, P2, etc) which can be adapted to the density and viscosity of the pumped liquid and show the number of pumps in operation
- product photos
- dimensional drawings
- wiring diagrams
- quotation texts, etc.

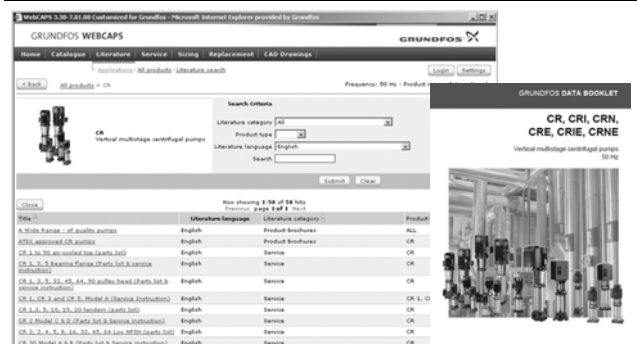

Literature

In this section you can access all the latest documents of a given pump, such as

- product guides
- installation and operating instructions
- service documentation, such as Service kit catalog and Service kit instructions
- quick guides
- product brochures, etc.

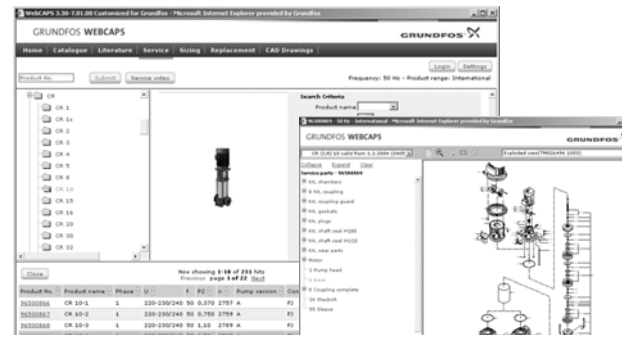

Service

This section contains an easy-to-use interactive service catalog. Here you can find and identify service parts of both existing and discontinued Grundfos pumps.

Furthermore, this section contains service videos showing you how to replace service parts.

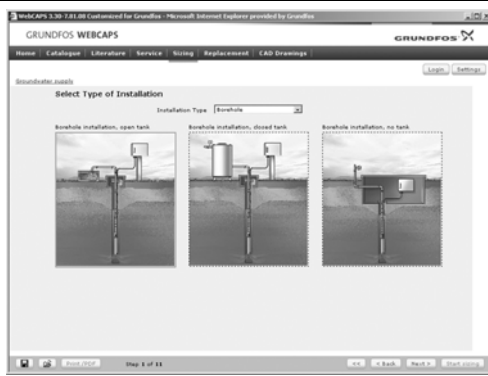

Sizing

This section is based on different fields of application and installation examples, and gives easy step-by-step instructions in how to

- select the most suitable and efficient pump for your installation
- carry out advanced calculations based on energy consumption, payback periods, load profiles, life cycle costs, etc.
- analyse your selected pump via the built-in life cycle cost tool
- determine the flow velocity in wastewater applications, etc.



Replacement

In this section you find a guide to selecting and comparing replacement data of an installed pump in order to replace the pump with a more efficient Grundfos pump. The section contains replacement data of a wide range of pumps produced by other manufacturers than Grundfos.

Based on an easy step-by-step guide, you can compare Grundfos pumps with the one you have installed on your site. When you have specified the installed pump, the guide will suggest a number of Grundfos pumps which can improve both comfort and efficiency.

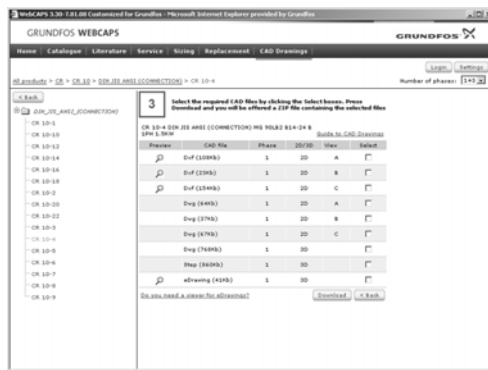

CAD drawings

In this section it is possible to download 2-dimensional (2D) and 3-dimensional (3D) CAD drawings of most Grundfos pumps.

These formats are available in WebCAPS:

2-dimensional drawings:

- .dxf, wireframe drawings
- .dwg, wireframe drawings.

3-dimensional drawings:

- .dwg, wireframe drawings (without surfaces)
- .stp, solid drawings (with surfaces)
- .eprt, E-drawings.



WinCAPS



Fig. 28 WinCAPS CD-ROM

WinCAPS is a **Windows-based Computer Aided Product Selection** program containing detailed information on more than 185,000 Grundfos products in more than 20 languages.

The program contains the same features and functions as WebCAPS, but is an ideal solution if no Internet connection is available.

WinCAPS is available on CD-ROM and updated once a year.

L-SP-PG-001 0212

Repl. L-SP-PG-001 Rev. 0206

US

© 2006, 2012 Grundfos Pumps Corp.

The name Grundfos, the Grundfos logo, and the payoff Be-Think-Innovate are registered trademarks owned by Grundfos Management A/S or Grundfos A/S, Denmark. All rights reserved worldwide.